

**TM 10-5410-224-14**

DEPARTMENT OF THE ARMY TECHNICAL MANUAL

---

**TECHNICAL MANUAL**

**OPERATOR, ORGANIZATIONAL, DIRECT SUPPORT,  
AND GENERAL SUPPORT MAINTENANCE MANUAL**

**FOR**

**SHELTER, EXPANDABLE FOR SHOP, PORTABLE,  
AIRCRAFT MAINTENANCE (SPAM)**

**NSN 5410-01-003-2933**

---

HEADQUARTERS, DEPARTMENT OF THE ARMY  
FEBRUARY 1977



### **WARNING**

1. A minimum of four men are required for deploying the expandable shelter.
2. When installing the expandable shelter in high winds, be sure to have at least two men guide each foldout and swingout wall, floor, and roof into place. Serious injury can result from free-swinging units.
3. Dangerous voltages exist in the electrical system of this equipment. Use extreme care when working on the components of the electrical system. Serious injury or death may result from contact with voltages contained in the electrical system.



**CHANGE  
NO. 3**

**HEADQUARTERS, DEPARTMENT OF THE ARMY  
WASHINGTON, DC, 30 SEPTEMBER 2005**

**TECHNICAL MANUAL**

**OPERATOR, ORGANIZATIONAL, DIRECT SUPPORT AND GENERAL SUPPORT  
MAINTENANCE MANUAL**

**FOR  
SHELTER, EXPANDABLE FOR SHOP, PORTABLE,  
AIRCRAFT MAINTENANCE (SPAM)**

**(NSN: 5410-01-003-2933)**

**DISTRIBUTION STATEMENT A:** Approved for public release; distribution is unlimited.

TM 10-5410-224-14, 16 February 1977, is updated as follows:

1. File this sheet in front of the manual for reference.
2. This change implements Army Maintenance Transformation and changes the Maintenance Allocation Chart (MAC) to support Field and Sustainment Maintenance.
3. New or updated change information is indicated by a vertical bar in the outer margin of the page.
4. Remove old pages and insert new pages as indicated below:

**Remove Pages**

D-1 – D-3/(D-4 Blank)

Sample 2028/Envelope  
2028

**Insert Pages**

A/(B Blank)

D-1 – D-7/(D-8 Blank)

Electronic 2028 Instructions/Blank

Sample 2028 Front/Back

2028 Front/Back

2028 Front/Back

TM 10-5410-224-14  
C3

By Order of the Secretary of the Army:

**PETER J. SCHOOMAKER**  
General, United States Army  
*Chief of Staff*

Official:

  
SANDRA R. RILEY  
*Administrative Assistant to the  
Secretary of the Army*  
0523403

Distribution: To be distributed in accordance with initial distribution number (IDN) 251618 requirements for TM 10-5410-224-14.

# URGENT

TM 10-5410-224-14  
C 2

CHANGE }  
NO. 2 }

HEADQUARTERS  
DEPARTMENT OF THE ARMY  
WASHINGTON, D.C., 30 March 1989

## Operator, Organizational, Direct Support, and General Support Maintenance Manual

SHELTER, EXPANDABLE FOR SHOP, PORTABLE,  
AIRCRAFT MAINTENANCE (SPAM)  
NSN 5410-01-003-2933

TM 10-5410-224-14, 16 February 1977, is changed as follows:

1. Remove and insert pages as indicated below. New or changed text material is indicated by a vertical bar in the margin. An illustration change is indicated by a miniature pointing hand.

Remove pages

3-7 and 3-8  
3-21 and 3-22

Insert pages

3-7 and 3-8  
3-21 and 3-22

2. Retain this sheet in front of manual for reference purposes.

By Order of the Secretary of the Army:

**CARL E. VUONO**  
*General, United States Army*  
*Chief of Staff*

Official:

**WILLIAM J. MEEHAN, II**  
*Brigadier General, United States Army*  
*The Adjutant General*

### DISTRIBUTION:

To be distributed in accordance with DA Form 12-25A, Operator, Unit, Direct Support and general Support Maintenance requirements for Shelter, Expandable, Shop, Aircraft Maintenance, Portable.

# URGENT





CHANGE }  
No. 1 }

HEADQUARTERS  
DEPARTMENT OF THE ARMY  
WASHINGTON, D.C., 8 April 1988

Operator, Organizational, Direct Support,  
and General Support Maintenance Manual

SHELTER, EXPANDABLE FOR SHOP, PORTABLE,  
AIRCRAFT MAINTENANCE (SPAM)  
NSN 5410-01-003-2933

TM 10-5410-224-14, 16 February 1977, is changed as follows:

1. Remove and insert pages as indicated below. New or changed text material is indicated by a vertical bar in the margin. An illustration change is indicated by a miniature pointing hand.

Remove pages

4-1 through 4-4  
D-3/D-4

Insert pages

4-1 through 4-4  
D-3/D-4

2. Retain this sheet in front of manual for reference purposes.

By Order of the Secretary of the Army:

**CARL E. VUONO**  
*General, United States Army*  
*Chief of Staff*

**Official:**

**R. L. DILWORTH**  
*Brigadier General, United States Army*  
*The Adjutant General*

DISTRIBUTION:

To be distributed in accordance with DA Form 12-25A, Operator, Unit, Direct Support, and General Support Maintenance requirements for Shelter, Expandable, Shop, Aircraft Maintenance, Portable.



INSERT LATEST CHANGED PAGES. DESTROY SUPERSEDED PAGES.

**LIST OF EFFECTIVE PAGES**

NOTE: The portion of text affected by the changes is indicated by a vertical line in the outer margins of the page. Changes to illustrations are indicated by shaded or screened areas, or by miniature pointing hands. Zero in the "Change No." column indicates an original page.

Dates of issue for original and changed pages are:

Original .. 0 ..	16 February 1977	Change .. 2 ..	30 March 1989
Change .. 1 ..	8 April 1988	Change .. 3 ..	30 September 2005

**TOTAL NUMBER OF PAGES IN THIS PUBLICATION IS 144, CONSISTING OF THE FOLLOWING:**

<b>Page No.</b>	<b>Change No.</b>
Title	0
Warning	0
i-iv	0
1-0 - 1-4	0
2-1 - 2-5	0
3-1 - 3-7	0
3-8	2
3-9 - 3-20	0
3-21	2
3-22 - 3-46	0
4-1	1
4-2	0
4-3	1
4-4 - 4-13	0
5-1	0
6-1 - 6-4	0
7-1	0
8-1 - 8-2	0
9-1 - 9-4	0
10-1 - 10-2	0
11-1 - 11-5	0
12-1	0
A-1	0
B-1 - B-2	0
D-1 - D-7/(D-8 Blank)	3
I-1 - I-4	0
FO-1	0
Back Cover	0



TECHNICAL MANUAL }  
 No, 10-5410-224-14 }

HEADQUARTERS,  
 DEPARTMENT OF THE ARMY  
 WASHINGTON, DC. 16 February 1977

**OPERATOR, ORGANIZATIONAL, DIRECT SUPPORT,  
 AND GENERAL SUPPORT MAINTENANCE MANUAL:  
 SHELTER, EXPANDABLE FOR SHOP, PORTABLE,  
 AIRCRAFT MAINTENANCE (SPAM)**

**NSN 5410-01-003-2933**

REPORTING OF ERRORS

You can help to improve this manual by calling attention to errors and by recommending improvements. Your letter, DA Form 2028 (Recommended Changes to Publications and Blank Forms) and/or DA Form 2028-2 (Recommended Changes to Equipment Technical Manuals), may be used. Copies of DA Form 2028.2 are attached in the back of the manual for your use. Please mail your recommended changes directly to Commander, US Army Troop Support Command, ATTN: DRSTS-MPP, 4300 Goodfellow Blvd., St. Louis, MO 33120. A reply will be furnished directly to you.

		Paragraph	Page
<b>CHAPTER Section</b>	1. INTRODUCTION		
	I. General . . . . .	1-1	1-1
	II. Description and data . . . . .	1-5	1-1
<b>CHAPTER</b>	2. OPERATING INSTRUCTIONS	2-1	2-1
<b>CHAPTER Section</b>	3. OPERATOR/ORGANIZATIONAL MAINTENANCE INSTRUCTIONS		
	I. Service upon receipt of materiel . . . . .	3-1	3-1
	II. Movement to new worksite . . . . .	3-4	3-20
	III. Organizational maintenance repair parts, special tools and equipment . . . . .	3-6	3-21
	IV. Lubrication instructions . . . . .	3-9	3-22
	V. Operator and organizational preventive maintenance checks and services . . . . .	3-11	3-22
	VI. Organizational maintenance troubleshooting . . . . .	3-13	3-23
	VII. Maintenance of shelter body . . . . .	3-15	3-25
	VIII. Maintenance of electrical system . . . . .	3-24	3-41
<b>CHAPTER Section</b>	4. DIRECT AND GENERAL SUPPORT MAINTENANCE INSTRUCTIONS		
	I. Repair parts, special tools, and equipment . . . . .	4-1	4-1
	II. Troubleshooting . . . . .	4-4	4-1
	III. General rivet and insert repair . . . . .	4-6	4-2
	IV. Removal and installation of major components and assemblies . . . . .	4-9	4-4
<b>CHAPTER</b>	5. REPAIR OF SWINGOUT WALLS . . . . .	5-1	5-1
<b>CHAPTER</b>	6. REPAIR OF FOLDOUT END WALLS . . . . .	6-1	6-1
<b>CHAPTER</b>	7. REPAIR OF FOLDOUT FLOOR PANELS . . . . .	7-1	7-1
<b>CHAPTER</b>	8. REPAIR OF FOLDOUT ROOF PANELS . . . . .	8-1	8-1
<b>CHAPTER</b>	9. REPAIR OF CENTER STRUCTURE ROOF PANEL . . . . .	9-1	9-1
<b>CHAPTER</b>	10. REPAIR OF PERSONNEL AND CARGO END PANELS . . . . .	10-1	10-1
<b>CHAPTER</b>	11. REPAIR OF CENTER STRUCTURE FLOOR PANEL . . . . .	11.1	1-1

	Paragraph	Page
<b>CHAPTER</b> 12, REPAIR OF CIRCUIT BREAKER PANEL .....	12-1	12-1
<b>APPENDIX</b> A. REFERENCES .....		A-1
B. COMPONENTS OF END ITEM LIST. ....		B-1
c. ADDITIONAL AUTHORIZATION LIST (NOT USED) .....		
D. MAINTENANCE ALLOCATION CHART .....		D-1
E. EXPENDABLE SUPPLIES AND MATERIALS LIST (NOT USED)		
<b>INDEX</b> .....		I-1

## LIST OF ILLUSTRATIONS

Figure	Title	Page
1-1	Expandable shelter (TS 023651).....	1-0
1-2	Dimensions of the expendable shelter (TS 023662).....	1-2
1-3	General arrangement of the expandable shelter (TS023653).....	1-3
2-1	Power entrance panel and circuit breaker panel (TS 023654).....	2-2
2-2	Ventilation fan switch (TS 023655).....	2-3
3-1	Stowage locations (Sheet 1 of 3)(TS 02366).....	3-2
3-1	Stowage locations (Sheet 2 of 3) (TS 023657).....	3-3
3-1	Stowage locations (Sheet 3 of 3)(TS 023658).....	3-4
3-2	Personnel end panel (TS 023659).....	3-5
3-3	Leveling jack deployment (TS 023660).....	3-6
3-4	Leveling jack installation (TS 023661).....	3-7
3-5	Deployment of foldout roof panels (TS 023662).....	3-8
3-6	Deployment of foldout floor panels (TS 023663).....	3-9
3-7	Deployment of foldout end walls (TS 023664).....	3-10
3-8	Unlocking swingout walls (TS 023665).....	3-11
3-9	Deployment of swingout walls (TS 023666).....	3-12
3-10	Anchor installation (TS 023667).....	3-13
3-11	Electrical installation (Sheet 1 of 2) (TS 023668).....	3-15
3-11	Electrical installation (Sheet 2 of 2) (TS 023669).....	3-16
3-12	ECU panel inclosed position (TS 023670).....	3-17
3-13	ECU panel inside view (TS 023671).....	3-18
3-14	Deployment of ECU panel (TS 023672).....	3-19
3-15	Repairing minor panel damage (TS 023673).....	3-26
3-16	Personnel end panel assembly (TS 023674).....	3-30
3-17	Safety cable, latch assembly, and related parts (TS 023675).....	3-32
3-18	Mobiliser fitting and shear plate (TS 023676).....	3-33
3-19	Striker and related parts (TS 023677).....	3-34
3-20	Personnel and right cargo doors handle and lock (TS 023678).....	3-35
3-21	Personnel and right cargo doors assembly (TS 023679).....	3-36
3-22	Personnel and cargo doors vent installation (TS 023660).....	3-37
3-23	Cargo end panel assembly (TS 023681).....	3-38
3-24	Left cargo door assembly (TS 023682).....	3-40
3-25	Not used	
3-26	Exterior light assembly (TS 023684).....	3-43
3-27	Ventilation fan assembly (TS 023685).....	3-45
4-1	Field installation of inserts (TS 023686).....	4-3
4-2	Swingout wall assembly (TS 023687).....	4-5
4-3	Foldout end wall assembly (TS 023688).....	4-6
4-4	Swingout wallhinge (TS 023689).....	4-7
4-5	Foldout floor panel assembly (TS 023690).....	4-9
4-6	Foldout roof panel assembly (TS 023691).....	4-11
4-7	Circuit breaker panel assembly (TS 023692).....	4-12
6-1	Seal and frame assembly (TS 023693).....	6-2
6-2	ECU panel assembly (TS 023694).....	6-3
8-1	Support strut assembly and related parts (TS 023695).....	8-2
9-1	Center structure roof panel assembly (TS 0236S6).....	9-2
9-2	Fan stowage installation (TS 023697).....	9-3
9-3	Ceiling light retainer assembly (TS 023698).....	9-4
10-1	Ring and stud assembly and lift fitting(TS 023699).....	10-2
11-1	Center structure floor panel (TS 023700).....	11-2
11-2	Fixed floor skids and tine guide assembly (TS 023701).....	11-4

**LIST OF TABLES**

Number	Title	Page
2-1	Circuit Breakers, Receptacles, and Switches . . . . .	2-3
3-1	Inspection Upon Receipt of Expendable Shelter . . . . .	3-4
3-2	Operator Preventive Maintenance Checks and Services . . . . .	3-22
3-3	Organizational Preventive Maintenance Checks and Services . . . . .	3-22
3-4	Organizational Maintenance Troubleshooting . . . . .	3-24
3-5	Repair Materials . . . . .	3-25
3-6	Paint Data . . . . .	3-28
4-1	Direct and General Support Maintenance Troubleshooting . . . . .	4-1





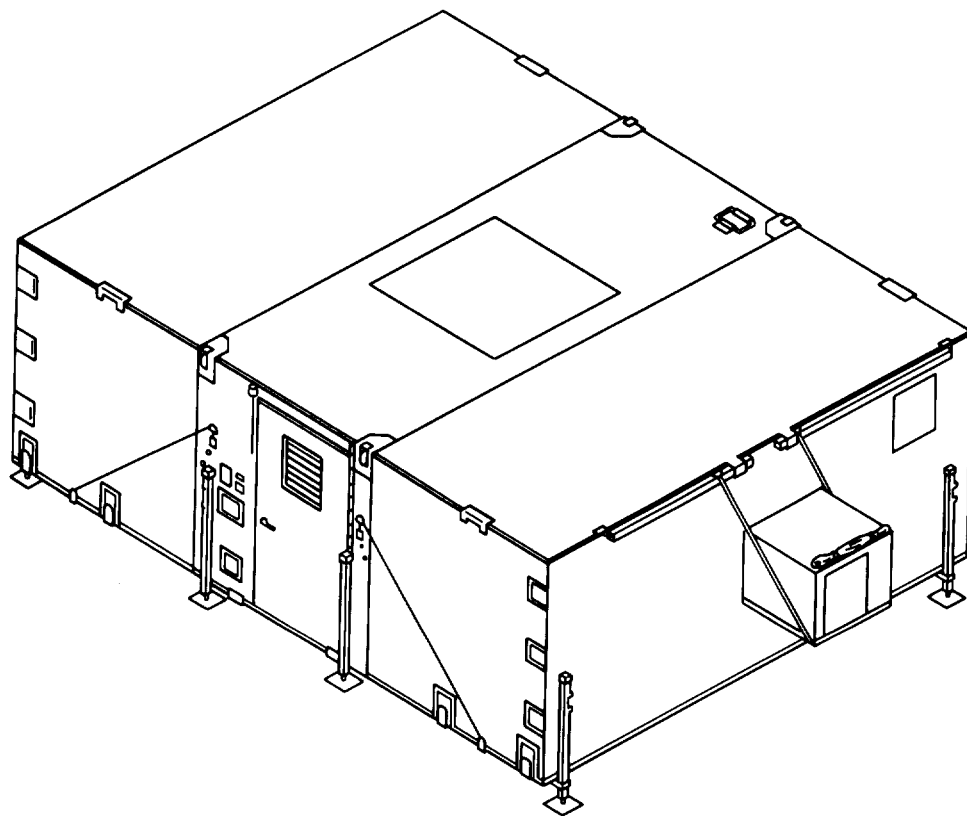

DEPLOYED  
SHELTER

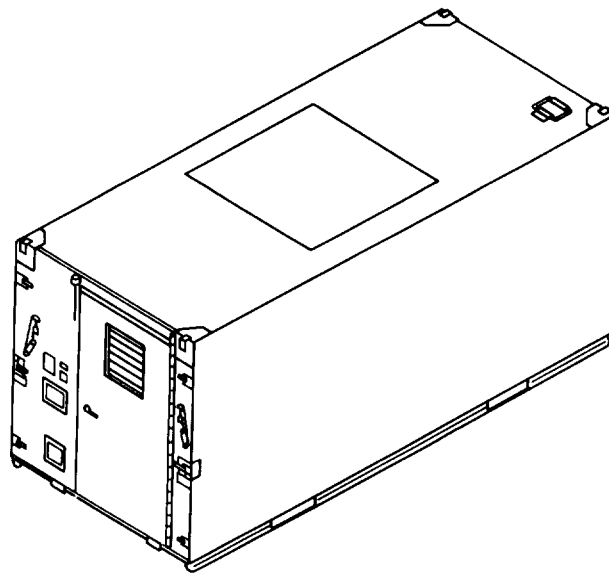

STOWED  
SHELTER

Figure 1-1. Expandable shelter

TS 023651

## CHAPTER 1

### INTRODUCTION

---

#### Section 1. GENERAL

##### 1-1. Scope.

This manual is for your use in operating and maintaining the expandable shelter for shop, portable, aircraft maintenance (SPAM) (fig. 1-1) herein referred to as the expandable shelter.

##### 1-2. Maintenance Forms and Records.

Maintenance forms and records that you are required to use are as follows:

- a. DA Form 2404 (Equipment Inspection and Maintenance Worksheet).
- b. DA Form 2407 (Maintenance Request Used for Requesting Support Maintenance).
- c. DA Form 2407-1 (Continuation Sheet Used for Requesting Support Maintenance).

d. For further information refer to TM 38-750 the Army Maintenance Management System (TAMMS).

##### 1-3. Destruction of Army Materiel to Prevent Enemy Use.

For destruction procedures for army materiel refer to TM 750-244-3.

##### 1-4. Administrative Storage.

For procedures, forms and records, and inspections required during administrative storage of this equipment, refer to TM 740-90-1.

#### Section II. DESCRIPTION AND DATA

##### 1-5. Description,

a. The expandable shelter unfolds from a packaged center structure (stowage mode) to an expanded shelter (deployment mode) (fig. 1-1). The overall dimensions of the expandable shelter in both the stowage mode and the deployed mode are given in fig. 1-2. The components that form the final expanded structure are hinged and folded into the center structure so that the unit may be expanded without removing whatever payload might be in the container. Two foldout roof panels shown

in figure 1-3 are hinged to the center structure roof, and two foldout floor panels are hinged to the center structure floor. Also, two foldout end walls are hinged to the foldout floor panels, and four swingout walls are hinged to the center structure cargo and personnel end panels. In expanded form, the shelter is supported by eight ratchet-handle leveling jacks. The leveling jacks are stored inside the center structure, along with deployment tools and equipment.

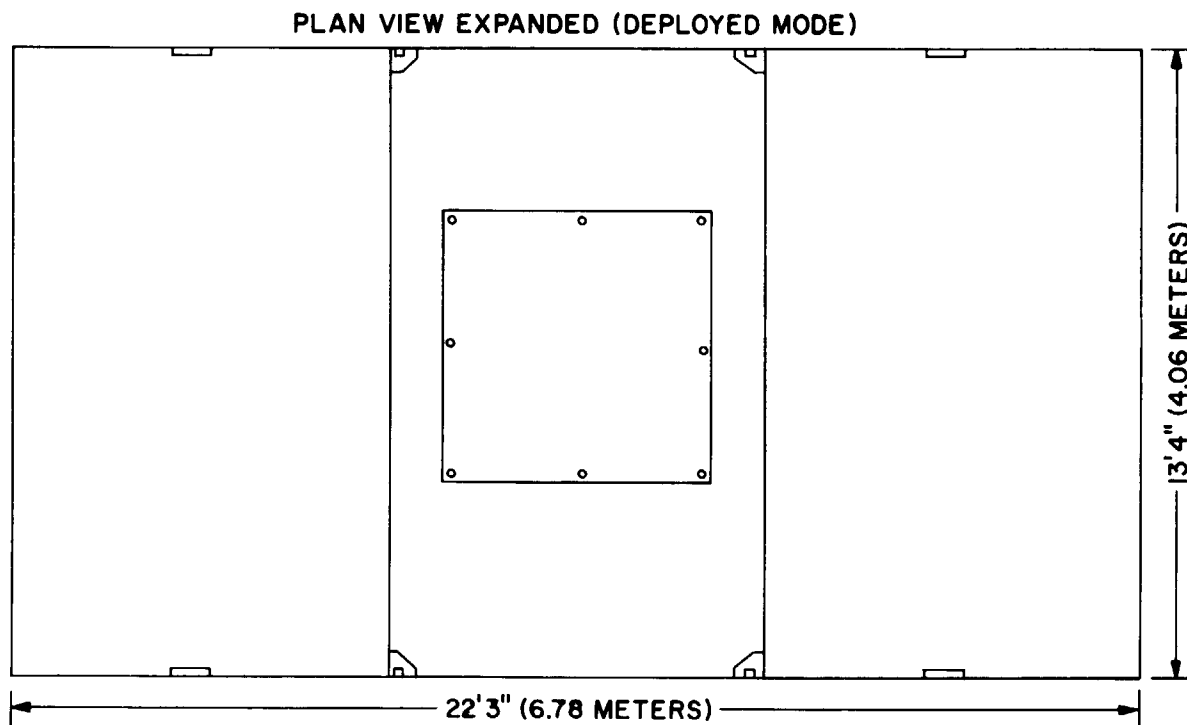
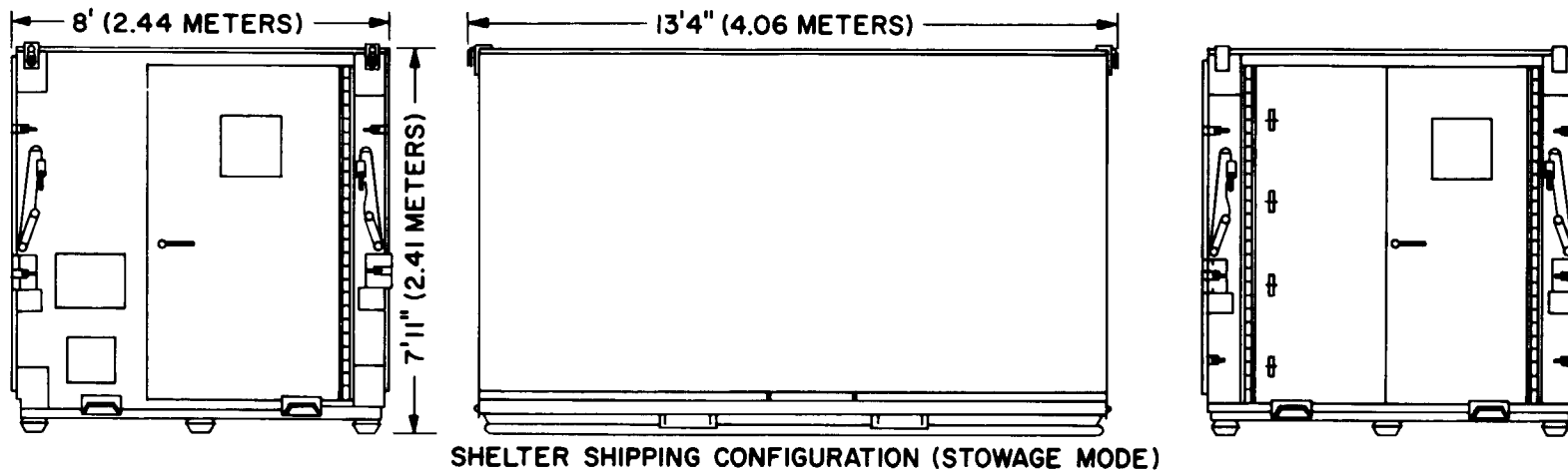

Figure 1-2. Dimensions of the expandable shelter

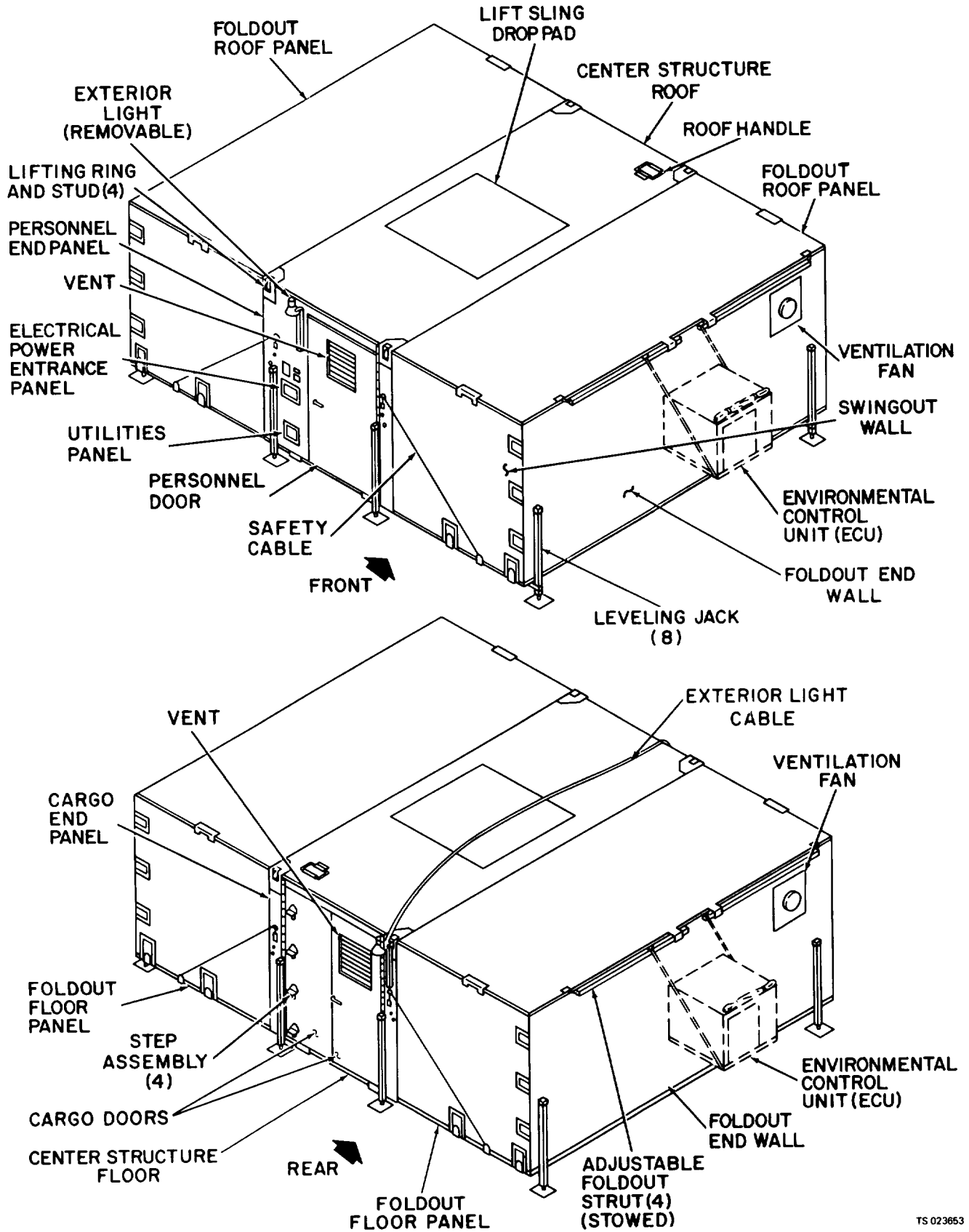

Figure 1-3. General arrangement of the expandable shelter

TS 023653

b. A lifting ring and stud are mounted on each top corner of the center structure. Double cargo doors (one with a vent) are installed in one end panel of the center structure, and a personnel door also with a vent is in the other end panel. Four step assemblies are mounted on the outside of one of the cargo doors to provide access to the shelter roof. A lift sling drop pad and roof handle are mounted on the center structure roof.

c. The two foldout end walls of the expandable shelter are designed to accommodate ventilation fans and environmental control units (ECU). The ventilation fans are installed when ECU units are not available. When ECU's are available and installed in the foldout end walls, the ventilation fans are not used and are left in the storage location. Separate power cables each with circuit breaker protection are provided in the shelter for the ventilation fans and for the ECU's. Separate control switches are also provided for the ventilation fans.

d. A power entrance panel (figure 1-3) is located on the outside of the personnel end panel. A connector on this panel receives the primary input power for the expandable shelter from an external source and routes it to a circuit breaker panel on the inside of the personnel end panel. The power is then distributed by the circuit breaker panel to internal lights and outlets and to the ventilation fans and/or ECU's. Power from the circuit breaker panel is also made available at two utility outlets located on the power entrance panel. Either one of the utility outlets can be used to supply power to the exterior light assembly which is normally attached to the personnel end panel next to the personnel door. However, the exterior light assembly may also be attached next to the cargo doors. For this purpose, the light is supplied with a 25-foot (7.5 meters) cable so that it can be routed from the utility outlet over the roof of the shelter to the cargo side.

1-6. Differences in Models.

This manual only covers the expandable shelter.

1-7. Tabulated Data.

Identification Plate .....	Located on personnel panel door Contains: Equipment nomenclature Type and designation number Manufacturer's part number, name, and code Contract number Serial number National stock number
Erection Sequence Instruction Plate .....	Located on personnel panel door. Contains sequence and instructions for erection of the expandable shelter.
Exterior Dimensions (Stowed Shelter)	Dimension
Width .....	8 ft (2.44 meters)
Height.....	7 ft, 11 in. (2.41 meters)
Length.....	13 ft, 4 in. (4.06 meters)
Exterior Dimensions (Deployed Shelter)	Dimension
Width . . . . .	22 ft, 3 in. (6.78 meters)
H e i g h t .	7 ft, 11 in. (2.41 meters)
Length.....	13 ft, 4 in. (4.06 meters)
Interior Dimensions	Dimension
Minimum clear height .	6 ft, 9 in. (2.06 meters)
Minimum clear width width ( s t o w e d m o d e )	6 ft, 6 in. (1.98 meters)
Total Weights .....	Weight
Less payload .....	4200 lbs (1905 kilograms)
With payload (maximum) .....	6000 (2721 kilograms)
Primary Power Requirements ..	120/208 Vac, 60 Hz, 3 phase, 5 wire
Environmental Limits .....	Limit
Operating temperature .....	-25°F to + 125°F (-31.7% to 51.7°C)
Maximum outer skin temperature. ....	+200 (93.3°C)
Transportability (Stowed Shelter).....	Method
Air.....	By aircraft, using 463L, or MH5.1.1970 cargo handling system, or suspended from a helicopter.
Water .....	By any mutable water vessel.
Rail.....	On a standard railway car as used in the continental United States, in accordance with methods and standards in the loading rules of the Association of American Railroads.
Land.....	By truck, fiat bed trailer, forklift or dolly set.

## CHAPTER 2

OPERATING INSTRUCTIONS

---

**NOTE**

If the equipment fails to operate, refer to troubleshooting procedures in Chapter 3.

**2-1. General.**

Operating instructions for the expandable shelter is limited to the operation of circuit breakers and switches for the purpose of applying power to lights, outlets, ventilation fans and ECU's. The operation of these circuit breakers and switches is covered in the following paragraphs.

**NOTE**

The physical locations of lights, ventilation fans, ECU's and utility outlets are shown in electrical installation illustration, figure 3-1 sheet 1 of 3.

**2-2. Lights.**

There are six ceiling-mounted fluorescent light assemblies inside the shelter in addition to an incandescent (emergency) light which is located above and to the left of the circuit breaker panel. Each pair of ceiling lights (left, center, and right) is controlled by separate switches mounted on the side of the circuit breaker panel. The emergency light is also controlled by a switch on the side of the circuit breaker panel. Each of these four switches is connected in series with a circuit breaker to provide protection against overloads. One other shelter light is the removable exterior light which is plugged into one of the utility outlets on the power entrance panel. Since separate circuit breakers control each of the utility outlets, the exterior light can be turned on and off from the appropriate circuit breaker. Identification of each circuit breaker and switch is given in figure 2-1 and in table 2-1.

**2-3. Ventilation Fans.**

Ventilation fans can be installed in each of the two foldout end walls of the shelter. When installed, each ventilation fan is controlled by a separate switch located above each installation location. These are three-position switches which are used to select either the exhaust or intake operation of the fan. The third position is off. Circuit breakers are connected in series with the two fan switches to protect against overloads. Figures 2-1 and 2-2 and table 2-1 identify the switches and circuit breakers.

**NOTE**

Normally, ventilation fans are not used if one or two ECU units are installed.

**2-4. ECU.**

The ECU's are not supplied with the expandable shelter. However, power cables with circuit breaker protection are provided in the shelter to accommodate the ECU's in two locations. The two circuit breakers are identified in figure 2-1 and table 2-1.

**2-5. Outlets.**

There are **12** duplex utility outlets located around the interior of the expandable shelter. In addition, there are two exterior outlets located on the power entrance panel as shown in figure 2-1. The 12 interior outlets are controlled in four groups of three by four circuit breakers. The two exterior outlets are controlled by separate circuit breakers. Figure 2-1 and table 2-1 identify these circuit breakers.

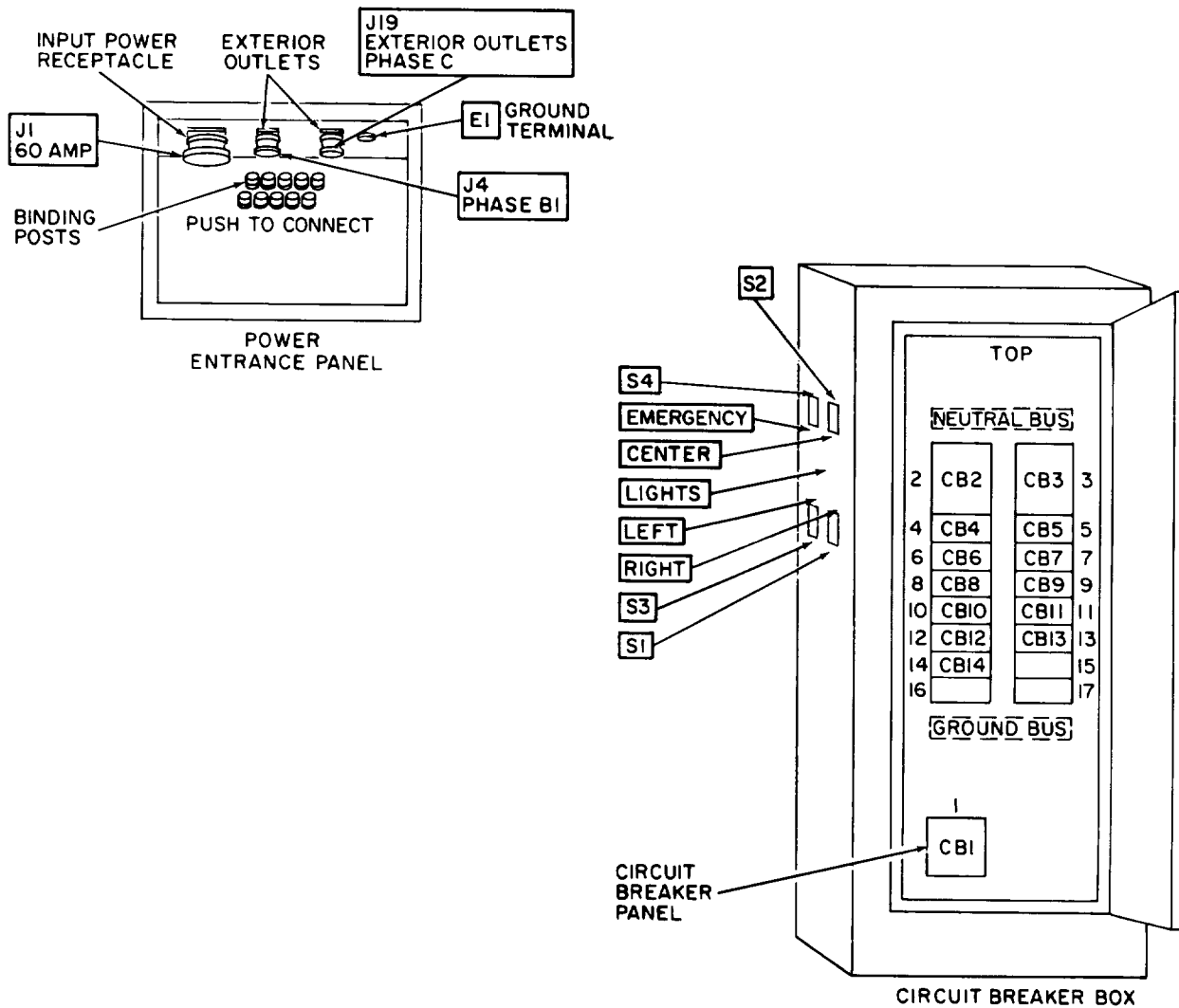

Figure 2-1. Power entrance panel and circuit breaker panel

TS 023654

**NOTE**  
Locations of units are described with reference to the power entrance panel and circuit breaker

panel, facing the expandable shelter at the personnel entrance.



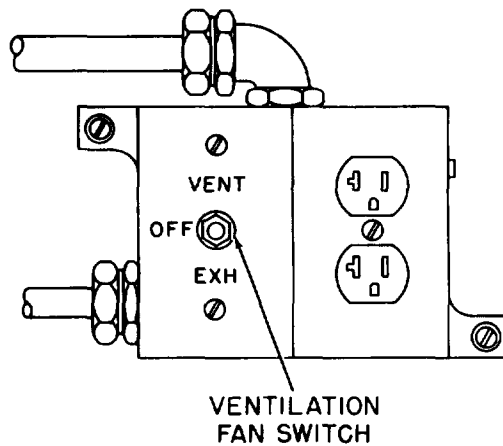

TS 023655

Figure 2-2. Ventilation fan switch

Table 2-1. Circuit Breakers, Receptacles, and Switches

Circuit breakers, receptacles, and switches	Location	Function
CB1	Circuit breaker panel	In ON position applies 120/208-volt, 3-phase, 60-Hz power to expandable shelter circuit breaker panel and provides overload protection.
CB2, CB3	Circuit breaker panel	In ON position, applies 120/208-volt, 3-phase, 60-Hz power to connectors P3 and P4 which are used to supply power to air conditioners. Also provide overload protection.
CB4	Circuit breaker panel	In ON position, makes 120 volt, single-phase (A), 60-Hz power available to switch S1 for application to right ceiling lights. Also provides overload protection.
CBS	Circuit breaker panel	In ON position, makes 120 volt, single-phase (B), 60-Hz power available to exterior outlet J4 on power entrance panel. Also provides overload protection.
CB6	Circuit breaker panel	In ON position, makes 120-volt, single-phase (B), 60-Hz power available to switch S2 for application to center ceiling lights. Also provides overload protection.
CB7	Circuit breaker panel	In ON position, makes 120-volt, single-phase (C), 60-Hz power available to exterior outlet J19 on power entrance panel. Also provides overload protection.
CB8	Circuit breaker panel	In ON position, makes 120-volt, single-phase (C), 60-Hz power available to switch S3 for application to left ceiling lights. Also provides overload protection.
CB9	Circuit breaker panel	In ON position, makes 120-volt, single-phase (B), 60-Hz power available to switch S4 for application to the incandescent light above the circuit breaker panel. Also provides overload protection.
CB10	Circuit breaker panel	In ON position, makes 120-volt, single-phase (A), 60-Hz power available to utility outlets J5, J6, and J7 located along right personnel end of shelter. Also provides overload protection.
CB11	Circuit breaker panel	In ON position, makes 120-volt, single-phase (B), 60-Hz power available to utility outlets J14, J15, and J16 located along left cargo end of shelter. Also provides overload protection.
CB12	Circuit breaker panel	In ON position, makes 120-volt, single-phase (C), 60-Hz power available to interior utility outlets J11, J12, and J13 located along right cargo end of shelter. Also provides overload protection.

Circuit breakers, receptacles, and switches	Location	Function
CB13	Circuit breaker panel	In ON position, makes 120-volt, single-phase (A), 60-Hz power available to interior utility outlets J8, J9, and J10 located along left personnel end of shelter. Also provides overload protection.
CB14	Circuit breaker panel	In ON position, makes 120-volt, single-phase (C), 60-Hz power available to switches S5 and S6 for application to the two ventilation fans. Also provides overload protection.
J1	Power entrance panel	Receives 120/208-volt, 3-phase, 60-Hz primary power from external source.
J4	Power entrance panel	Utility outlet provides 120-volt, single-phase (B), 60-Hz power for exterior light or other uses. Circuit protected against overload by circuit breaker CB5.
J5, J6, J7	Personnel end, right interior wall	Utility outlets provide 120-volt, single-phase (A), 60-Hz power for general use. Circuits protected against overload by circuit breaker CB10.
J8, J9, J10	Personnel end, left interior wall	Utility outlets provide 120-volt, single-phase (A), 60-Hz power for general use. Circuits protected against overload by circuit breaker CB13.
J11, J12, J13	Cargo end, right interior wall	Utility outlets provide 120-volt, single-phase (C), 60-Hz power for general use. Circuit protected against overload by circuit breaker CB12.
J14, J15, J16	Cargo end, left interior wall	Utility outlets provide 120-volt, single-phase (B), 60-Hz power for general use. Circuits protected against overload by circuit breaker CB11.
J17	Right foldout end wall	Ventilation fan connector mates with connector P1 to receive fan operating power as controlled by switch S5. Circuit protected against overload by circuit breaker CB14.
J18	Left foldout end wall	Ventilation fan connector mates with connector P2 to receive fan operating power as controlled by switch S6. Circuit protected against overload by circuit breaker CB14.
J19	Power entrance panel	Utility outlet provides 120-volt, single-phase (C), 60-Hz power for exterior light or other uses. Circuit protected against overload by circuit breaker CB7.
E1 P1	Power entrance panel Right foldout end wall	Ground stud for connecting earth ground to shelter. Mates with ventilation fan connector J17 to provide fan operating power as controlled by switch S5. Circuit protected against overload by circuit breaker CB14.
P2	Left foldout end wall	Mates with ventilation fan connector J18 to provide fan operating power as controlled by switch S6. Circuit protected against overload by circuit breaker CB14.
P3	Right foldout end wall	Mates with ECU connector to provide 3-phase operating power. Circuit protected against overload by circuit breaker CB3.
P4	Left foldout end wall	Mates with ECU connector to provide 3-phase operating power. Circuit protected against overload by circuit breaker CB2.
S1 RIGHT	Circuit breaker panel	In on (up) position, applies 120-volt, single-phase (A), 60-Hz power to right ceiling lights. Circuit protected against overload by circuit breaker CB4.
S2 CENTER	Circuit breaker panel	In on (up) position, applies 120-volt, single-phase (B), 60-Hz power to center ceiling lights. Circuit protected against overload by circuit breaker CB6.
S3 LEFT	Circuit breaker panel	In on (up) position, applies 120-volt, single-phase (C), 60-Hz power to left ceiling lights. Circuit protected against overload by circuit breaker CB8.
S4 EMERGENCY	Circuit breaker panel	In on (up) position, applies 120-volt, single-phase (B), 60-Hz power to emergency light over circuit breaker panel. Circuit protected against overload by circuit breaker CB9.
S5 VENT-OFF-EXH	Left foldout end wall, interior	In VENT position, applies 120-volt, single-phase (C), 60-Hz power to ventilation fan causing it to draw air in.
S6 VENT-OFF-EXH	Right foldout end wall, interior	In EXH position, applies 120-volt, single-phase (C), 60-Hz power to reverse winding of ventilation fan causing it to push air out.
		In OFF position, fan is shut off. In VENT position, applies 120-volt, single-phase (C), 60-Hz power to ventilation fan causing it to draw air in.

Circuit breakers, receptacles, and switches	Location	Function
Binding posts (push-to-connect)	Power entrance panel	<p>In EXH position, applies 120-volt, single-phase (C), 60-Hz power to reverse winding of ventilation fan causing it to push air out.</p> <p>In OFF position, fan is shut off.</p> <p>Used for outside telephone line connections. Jack-ends of binding posts inside shelter accommodate telephone plugs.</p>



**CHAPTER 3****OPERATOR/ORGANIZATIONAL MAINTENANCE INSTRUCTIONS**

---

**Section 1. SERVICE UPON RECEIPT OF MATERIEL****3-1. Inspecting and Servicing the Equipment.**

Inspect the expandable shelter (stowage mode) in accordance with procedures in table 3-1. Use a clean, soft-bristle brush to remove dust, dirt, and lint from all parts and surfaces of the expandable shelter. Clean walls with soap and water and a sponge or soft cloth.

**3-2. Installation.**

a. General. A minimum of 4 men are required to install (deploy) the expandable shelter. Tools and equipment for performing this operation are stowed in the equipment chest inside the expandable shelter (fig. 3-1). Access to this equipment is gained through the personnel door of the center structure .

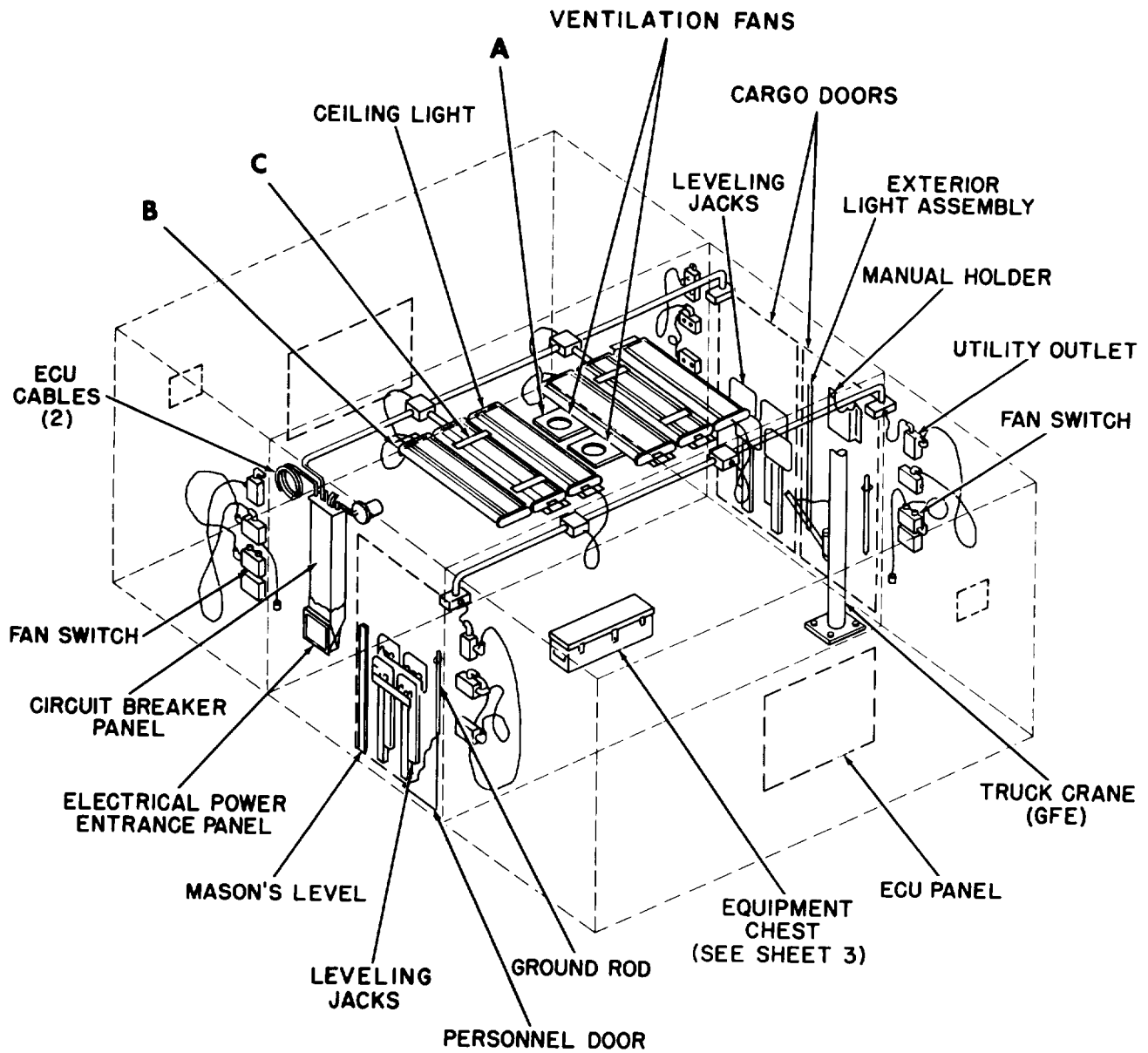

TS 023656

Figure 3-1. Stowage Locations (Sheet 1 of 3)

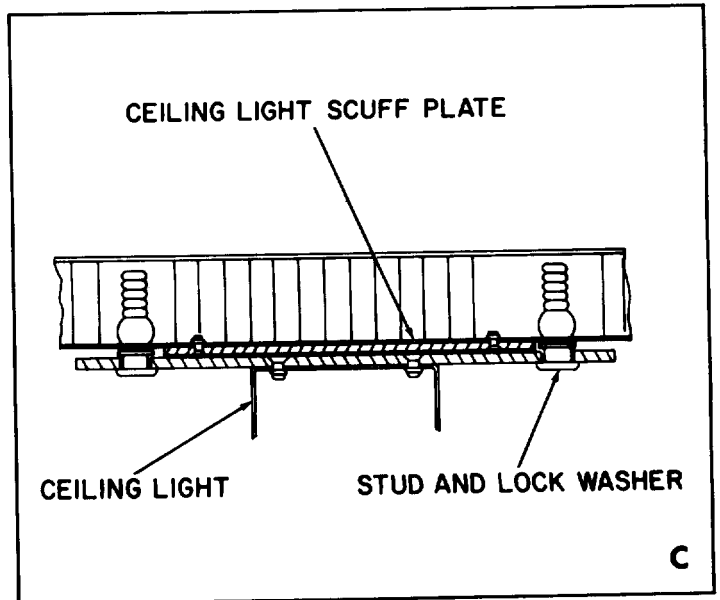
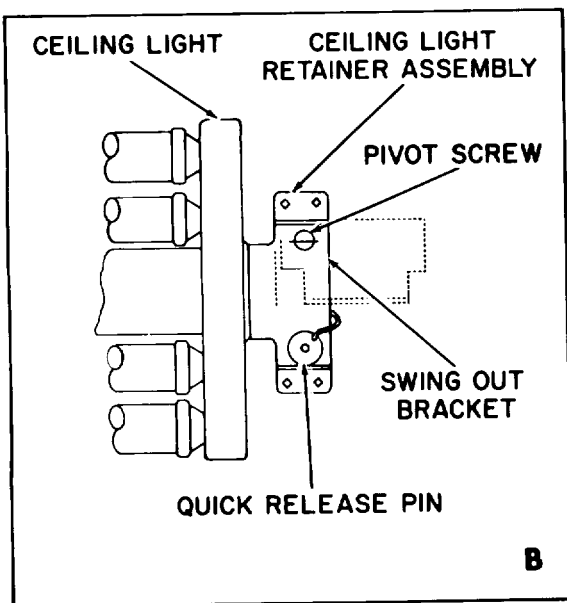
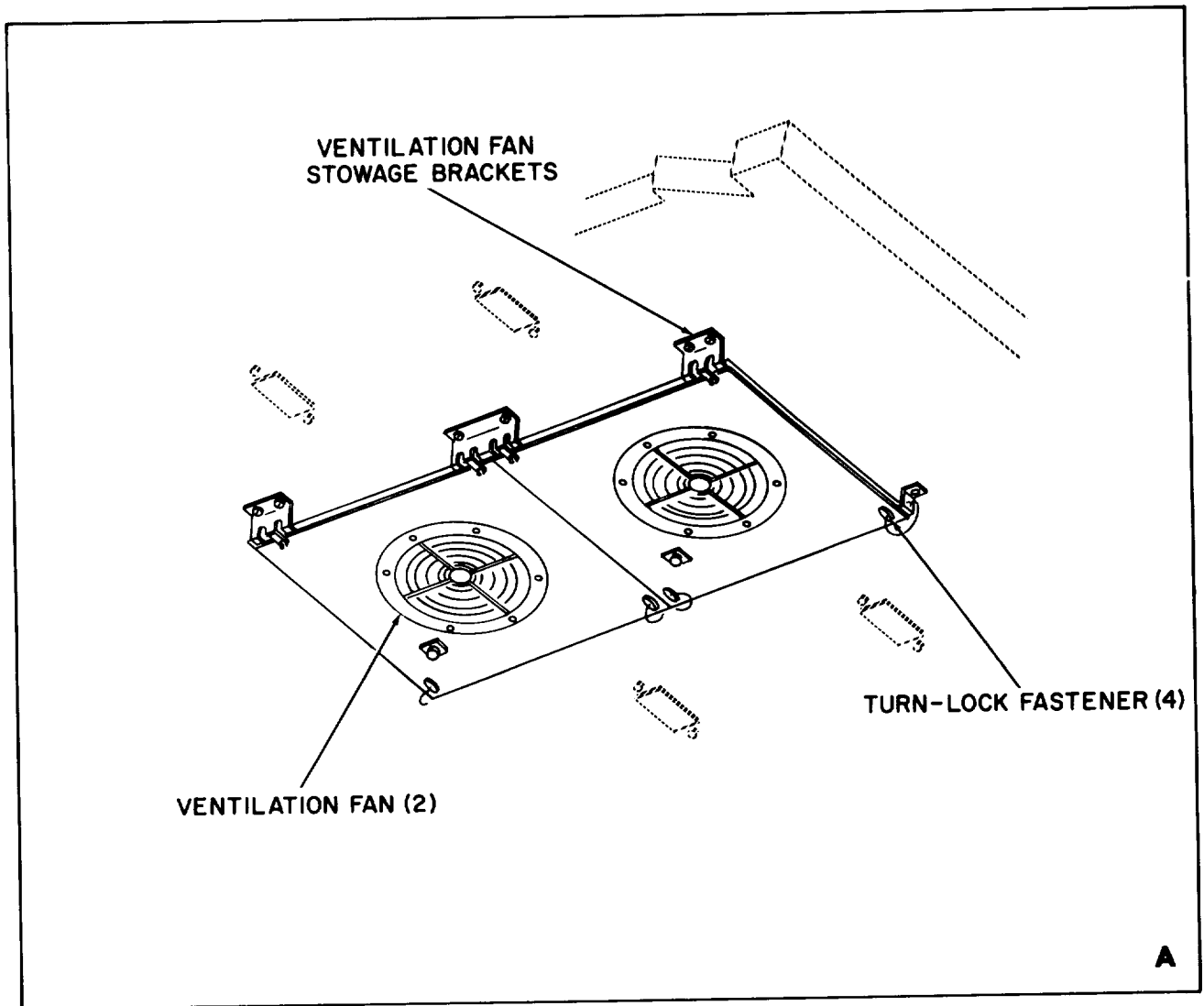

TS 023657

Figure 3-1. Stowage locations (Sheet 2 of 3)

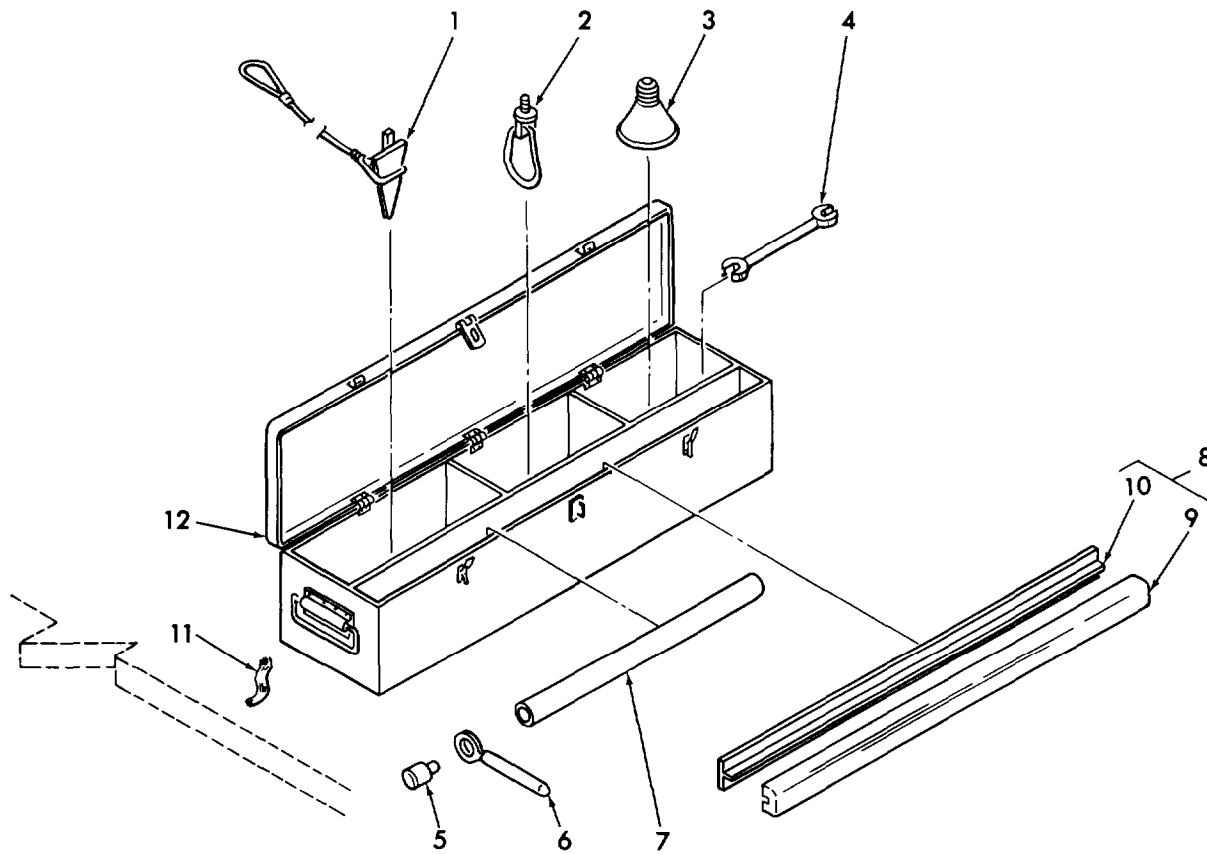

TS 023658

- |                       |                             |
|-----------------------|-----------------------------|
| 1. Ground Anchor (12) | 7. Driving Rod              |
| 2. Tiedown Ring (16)  | 8. ECU Seal Assembly        |
| 3. Flood Lamp         | 9. Rubber Seal              |
| 4. Open End Wrench    | 10. Seal Plate              |
| 5. Driving Head       | 11. Strap Assembly (2)      |
| 6. Holding Handle     | 12. Equipment Storage Chest |

Figure 3-1. Stowage locations (Sheet 3 of 3)

Table 3-1. Inspection Upon Receipt of Expandable Shelter

Component	Nature of Inspection
Personnel end panel, cargo end pad, and folded roof panels	Check condition of electrical connectors and grounding stud. Check for dirt, corrosion, and surface damage. Check condition of instruction plates and markers. Check security of jacking points. Check condition of latches, Check step installations for security and proper operation.
Bottom and base	Check security and condition of doors, vents, and seals. Check base for corrosion, cracks, bends, and punctures.
Top of center structure	Check that forklift guides are secure, unbent, and in generally good condition. Check surface integrity. Check roof handle for security and operation. Check lifting rings for security and corrosion.

b. Site Selection. A site with good accessibility, drainage, and reasonable maneuvering area for vehicles that will be used for hauling and hoisting should be selected. The terrain should be smooth, firm, well drained, and relatively free of surface rock or stone. The slope of the terrain must not exceed 18 inches over the projected floor area.

c. Handling. After the expandable shelter (stowage mode) has been delivered to the site, it must be fork-lifted, hoisted, or trucked to the deployed position. The center structure can be forklifted from any one of two sides, where locations for inserting the forklift tines are marked. Hoisting or lifting rings are located on each roof



corner of the center structure. The angle of the hoisting cable from the ring to the hook must be 45 degrees or greater from the top of the center structure. The hoisting vehicle and cables must be of a size to handle a shelter weight (with payload) of 6000 pounds.

**3-3. Shelter Conversion.**

The following procedure contains the instructions for deploying the expandable shelter.

**WARNING**

A minimum of four men are required for

**deploying the expandable shelter. When installing the expandable shelter in high winds, be sure to have at least two men guide each foldout and swingout wall, roof and floor into place. Serious injury can result from free-swinging units.**

**NOTE**

Refer to ERECTION SEQUENCE placard on personnel end panel (fig. 3-2) above power entrance panel as required during deployment.

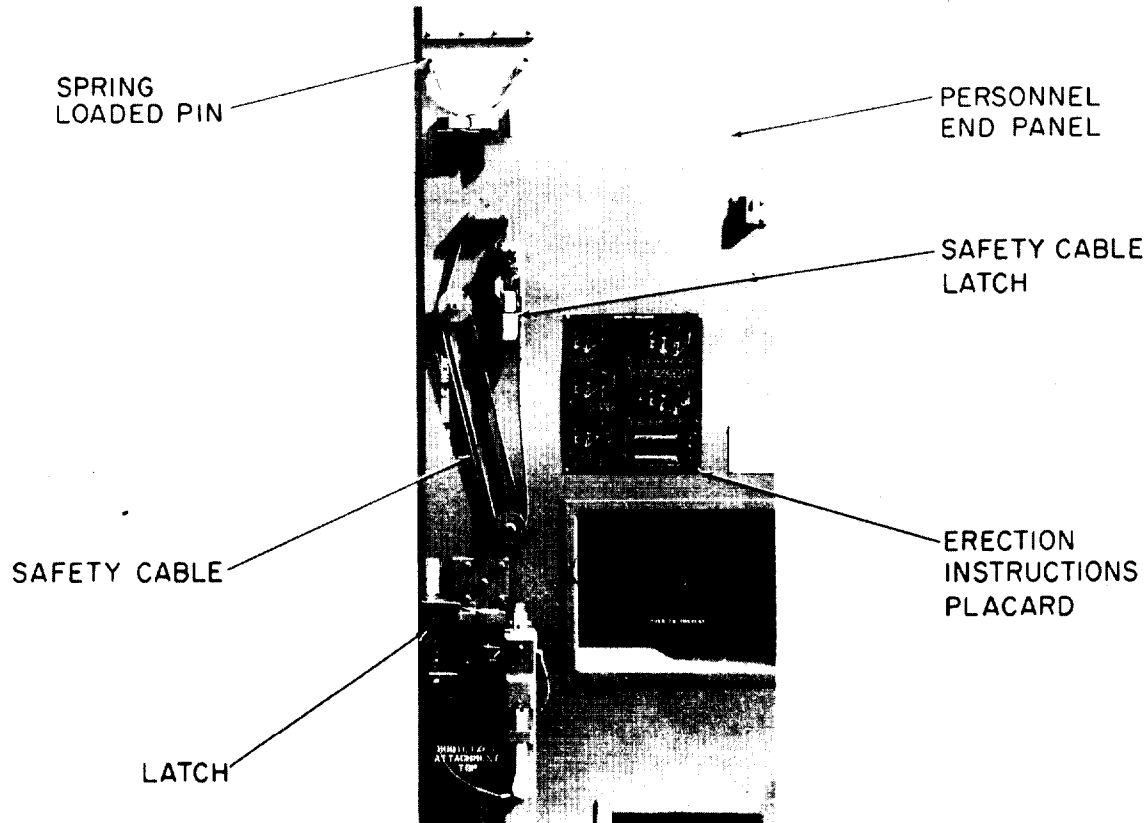

Figure 3-2. Personnel end panel

a. Expanding and Leveling Shelter. Expand and level the shelter as follows:

(1) Position shelter on site so that it will not have to be moved after weight has been placed on jacks.

(2) Enter shelter through personnel door and remove leveling jacks from stored position on cargo and personnel door.

(3) Install one jack at each corner of center structure (fig. 3-3). Make certain pins on jack lift engage sockets under shelter floor, that jack support clip properly engages jack support plate at each corner, and that safety pin for each jack is fastened in place. (See fig. 3-4.)

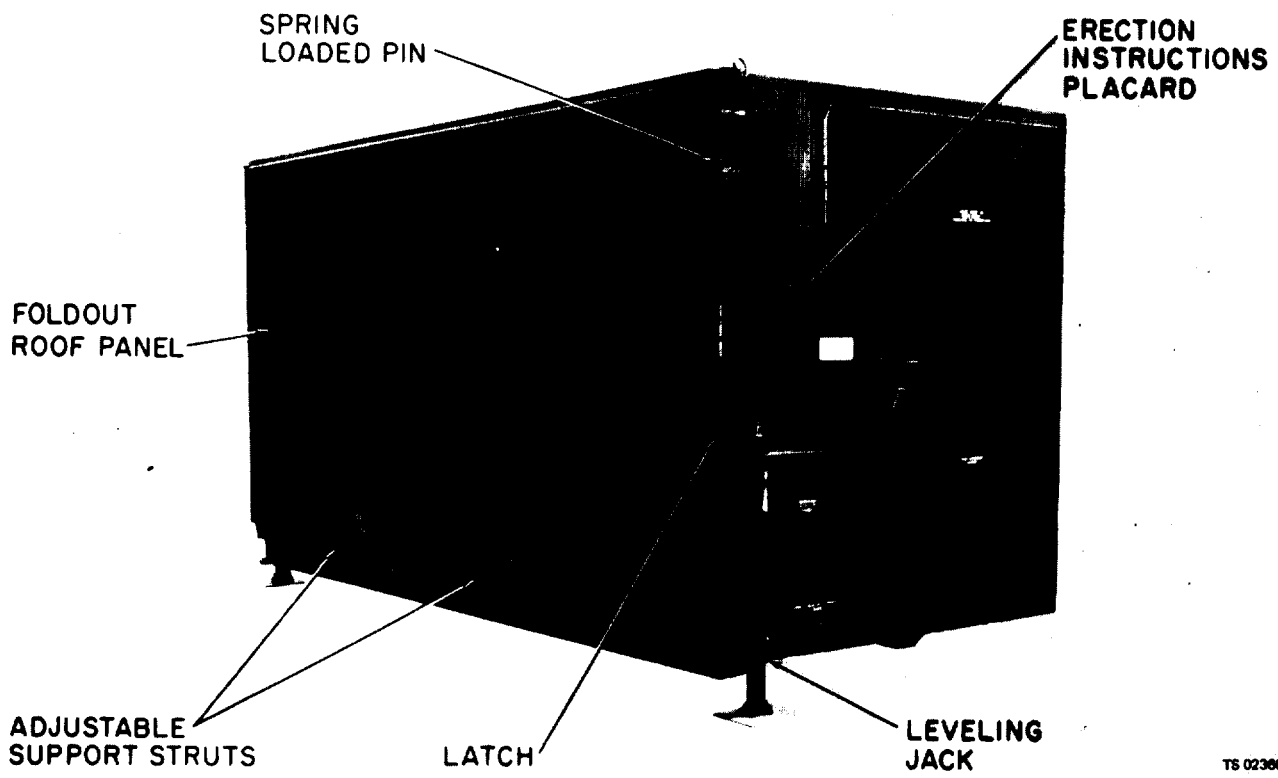

TS 02306

Figure 3-3. Leveling jack deployment

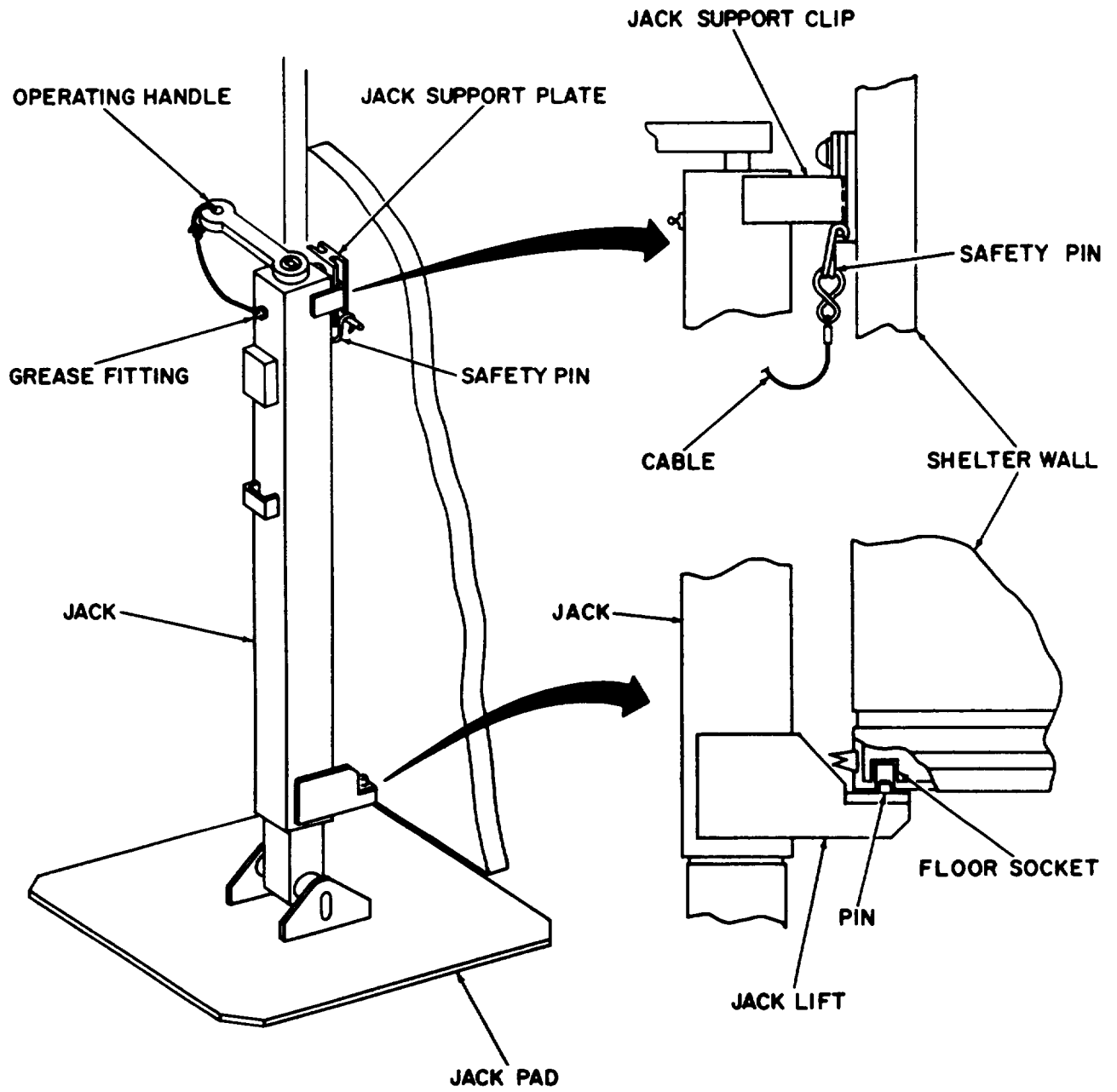

Figure 3-4. Leveling jack installation

(4) Raise and level shelter (fig. 3-4) as follows: Raise two jacks simultaneously to prevent excessive wear on jacks. Place level on center of center structure floor, parallel to 13-foot direction. Raise structure with two jacks determined to be on low end first. Level shelter in this direction. Turn level to rim parallel with 8-foot direction. Level shelter in this direction by raising two jacks determined to be low first. Raise shelter enough so that all parts of base clear the ground when shelter is level: Recheck level in all directions.

**WARNING**

One roof section weight 150 pounds. Floor and wall weigh approximately 375 pounds. The floor section must be physically checked for lack of force movement to verify that the spring loaded pins (figures 3-3 and 3-5) are securing the floor to the shelter.

Do not use strut as lever arm. Place strut in stowed position after erection.

**CAUTION**

Make sure that struts are properly positioned so that they are in a perfectly vertical position and not bent or twisted.

(5) Unlatch and raise one foldout roof panel as follows: Unpin, lower, and extend the two adjustable support struts (fig. 3-5) to support the foldout roof panel. Raise foldout roof panel to level position, supported by struts on ground. Check level, then extend strut height by one hole, so that foldout roof panel is at sufficient height to clear other sections when they are swung outward.

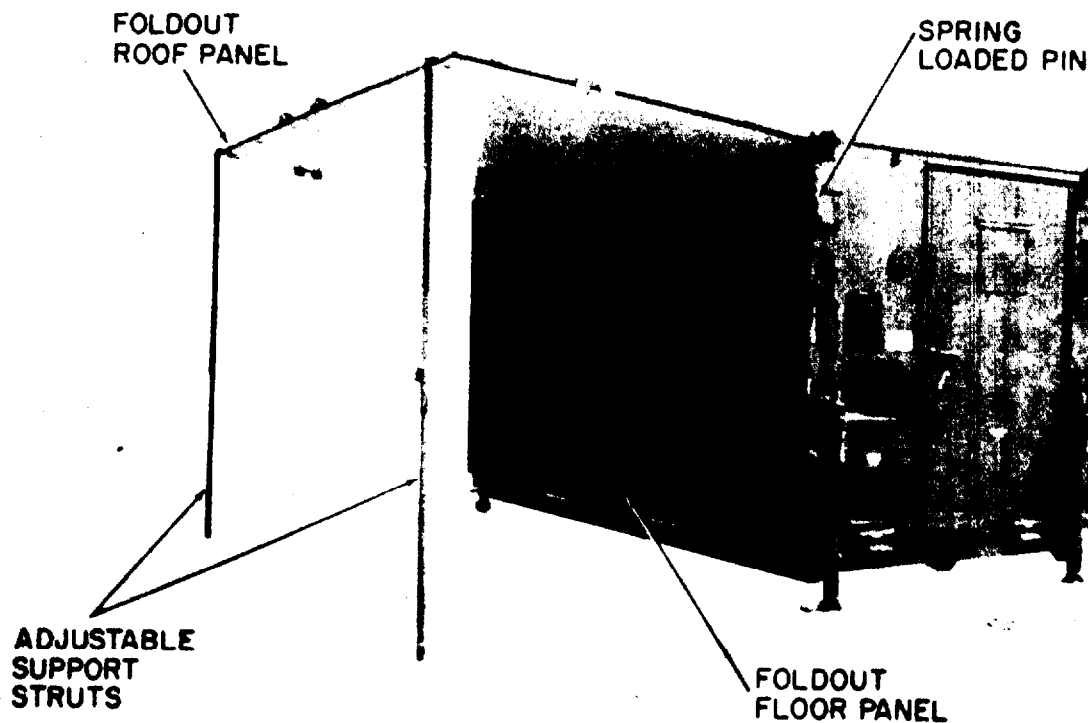
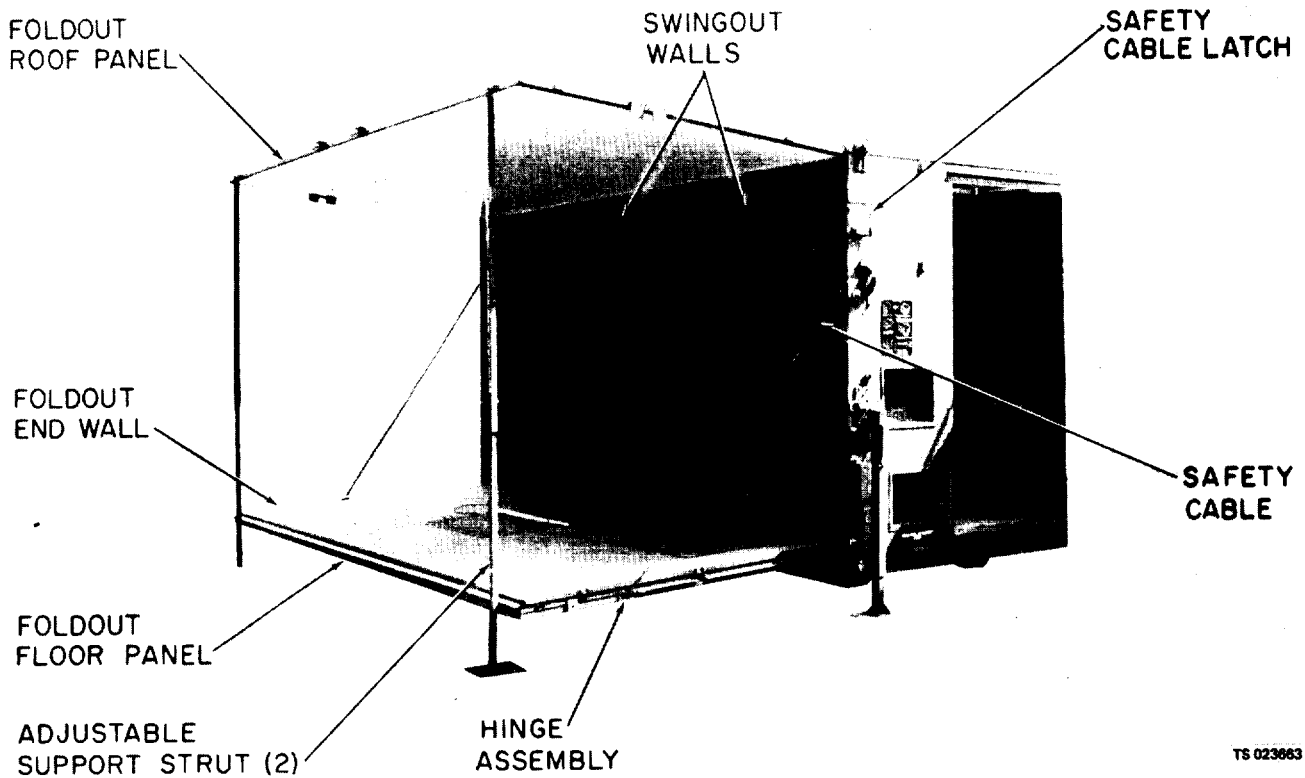

Figure 3-5. Deployment of foldout roof panel

**WARNING**

Make certain that the adjustable support struts are firmly positioned and safely holding the foldout roof panel.

(6) Release latches securing safety cables (fig. 3-2) to personnel and cargo end panels, and attach safety cables to hinge assembly (fig. 3-6) on foldout floor panel assembly.



TS 023663

Figure 3-6. Deployment of foldout floor panel

**WARNING**

Floor and wall weigh approximately 375 pounds.

(7) Release spring-loaded pins (fig. 3-5) and proceed to lower foldout floor panel to horizontal position. Floor is supported by safety cables (fig. 3-6).

(8) When foldout floor panel is below horizontal (safety cables fully extended), raise foldout end wall (fig. 3-7) to vertical position and hold.

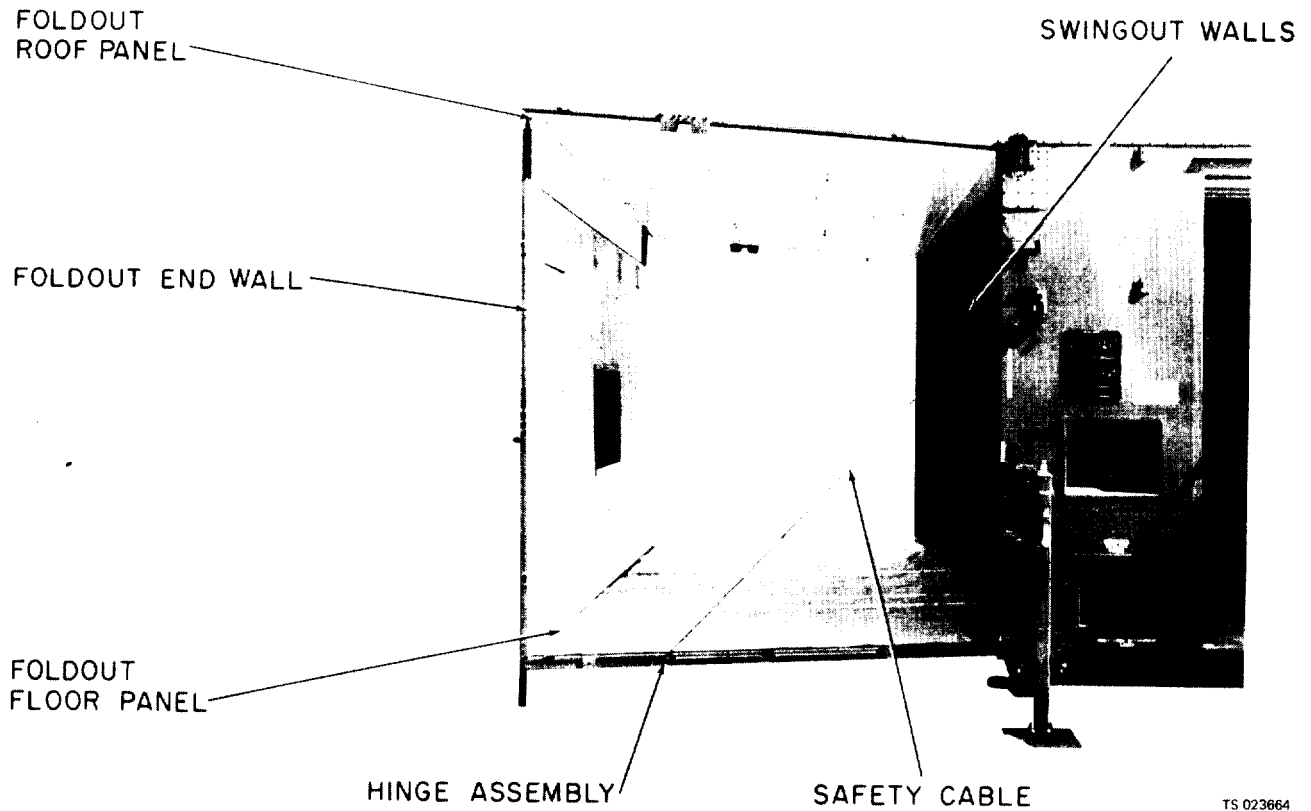

TS 023664

Figure 3-7, Deployment of foldout end wall

**CAUTION**

The shelter is designed for temperatures between  $-25^{\circ}\text{F}$  ( $-31.7^{\circ}\text{C}$ ) and  $+125^{\circ}\text{F}$  ( $51.7^{\circ}\text{C}$ ). However, when temperature is approximately  $0^{\circ}\text{F}$  ( $-17.8^{\circ}\text{C}$ ) or lower, use extreme care when unfolding swingout walls. Since electrical cables can be brittle at these low temperatures, the walls should be folded out slowly and carefully. If

possible, warm shelter to approximately  $32^{\circ}\text{F}$  ( $0^{\circ}\text{C}$ ) before deploying cables.

**WARNING**

If high winds exist, at least two men must guide each swingout wall into position and hold it until it is secured.

(9) Inside shelter, disengage ball-lock pins (fig. 3-8), swing swingout walls outward and hold them in position (fig. 3-9).

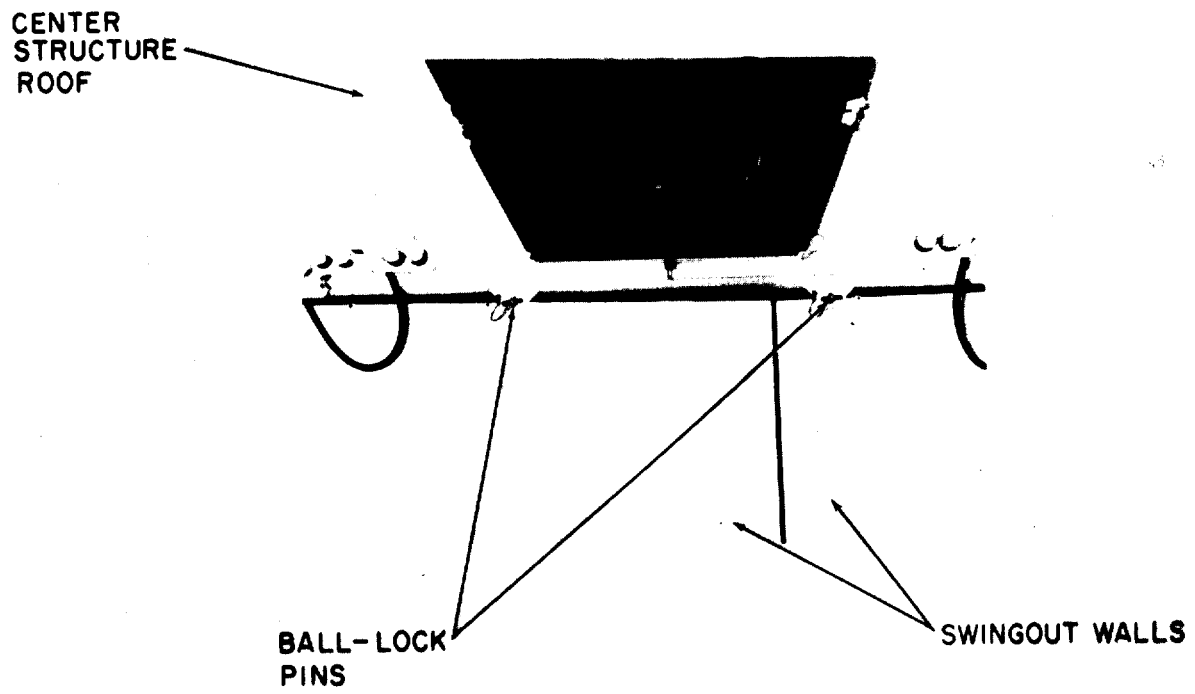

TS 023005

Figure 3-8. Unlocking swingout walls

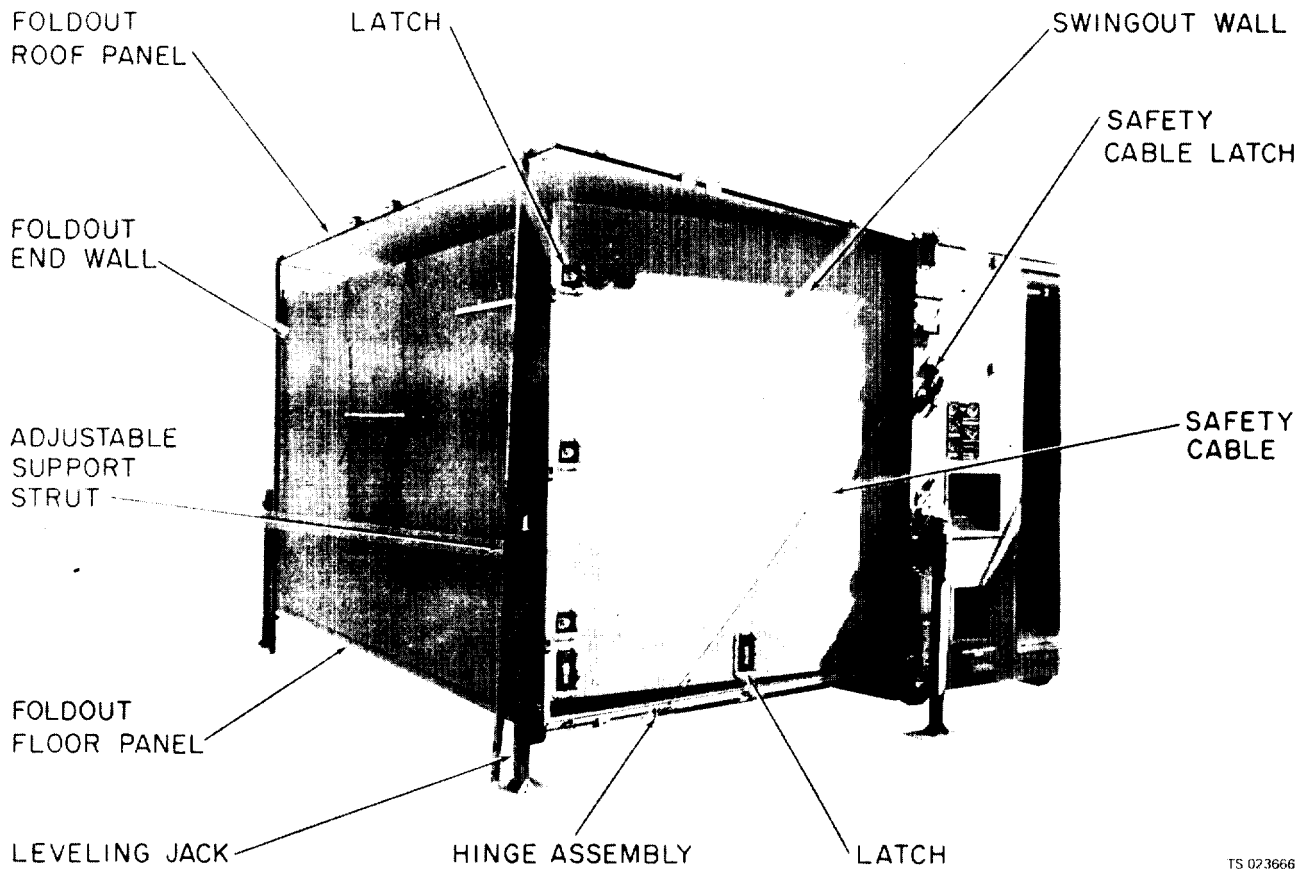

TS 023666

Figure 3-9. Deployment of swingout walls

(10) Install jacks at each corner of expanded section.

(11) Jack floor to horizontal position and lock all swingout wall latches (both sides). Lock latches on safety cables.

(12) Lower foldout roof panel with support struts to meet foldout end wall and two swingout walls. Latch foldout roof panel to walls inside shelter. Latch the foldout floor panel and then the foldout end wall to the swingout walls.

(13) Pin roof support struts in stowed (shipping) position (fig. 3-3).

(14) Repeat steps (5) through (13) above to expand second section of shelter.

(15) Check level of expanded sections and make adjustments as necessary.

b. Ground Anchor Installation. Remove the 12 ground anchors, driving rod, holding handle, driving head, and tie-down rings from the

equipment chest stowed in the center structure (figure 3-1). The following items, which are not furnished with the shelter, are required to install the anchors:

Item	Quantity
Five-pound sledge hammer	1
Crescent wrench	1

The following procedures provide instructions for installing the ground anchors.

(1) Basic anchor installation.

(a) Insert driving rod on top of triangular anchor into hole in end of driving rod.

(b) Slip loop of holding handle over driving rod.

(c) Place driving head on driving rod.

(d) Support driving rod with holding handle, and use sledge hammer to drive anchor into ground at angle noted in figure 3-10.



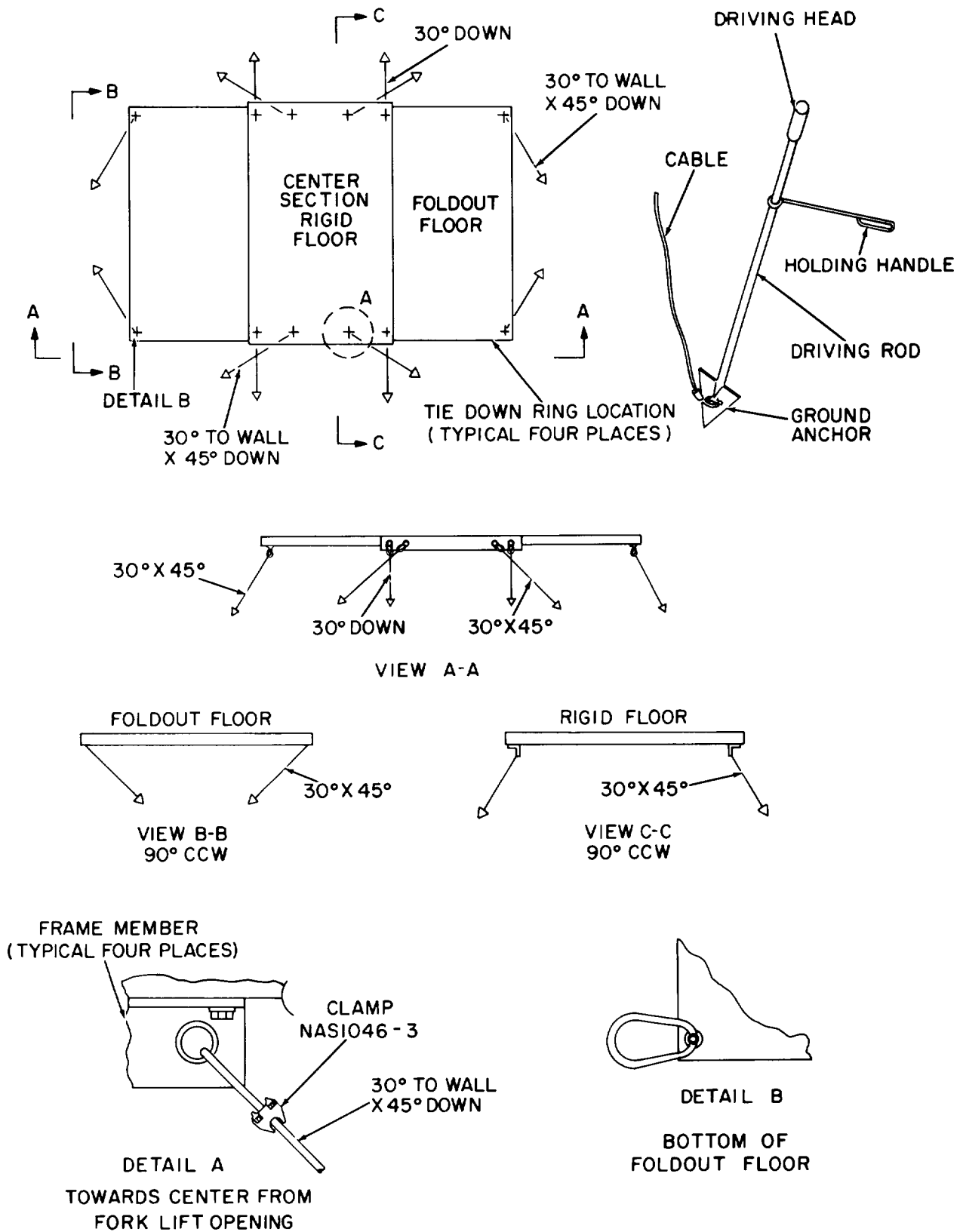

TS 023667

Figure 3-10. Anchor installation

**WARNING**

Driving head and holding handle must be used when driving an anchor.

(e) Drive anchor approximately 3 feet into ground.

(f) Remove driving head, holding handle, and driving rod.

(g) Set anchor by forming a loop in cable end (secure loop with cable clamp). Insert driving rod through this loop and pull up sharply, assuring anchor has been set. Remove clamp, attach cable to shelter and replace cable clamp (see fig. 3-10).

**NOTE**

This setting of the anchor is required to turn the anchor in the ground so that it develops maximum holding power.

(2) Installation of eight center structure anchors.

(a) Install two anchors on each side of center structure, straight out from holes in angle under floor pallet, so that cables, when attached, are 30 degrees down as shown in figure 3-10.

(b) Install two more anchors on each side of center structure so that cables attached between shelter and anchor are 30 degrees to wall and 45

degrees down. Each cable connects through a hole in the center structure frame member (see detail A, fig. 3-10).

(3) Installation of sidewall anchors. Install two anchors at each sidewall so that when cables are connected to shelter at locations shown in figure 3-10, the cables are 30 degrees to wall and 45 degrees down. Screw tie-down rings into bottom of foldout floors on foldout end wall sides at locations indicated in figure 3-10.

c. Ground Rod Installation. Drive ground rod into the earth at a suitable location that permits ground cable attached to the rod to reach the ground stud (E1) on the power entrance panel. Attach ground cable to ground stud (E1).

**WARNING**

Make certain that power cable is not connected to power entrance panel. Turn all circuit breakers on circuit breaker panel to the off position.

d. Light Fixture Installation. The installation of light fixtures is as follows:

(1) Pull out quick-release pin from holding bracket which secures a ceiling light that is to be relocated. (See fig. 3-1 and 3-11.)

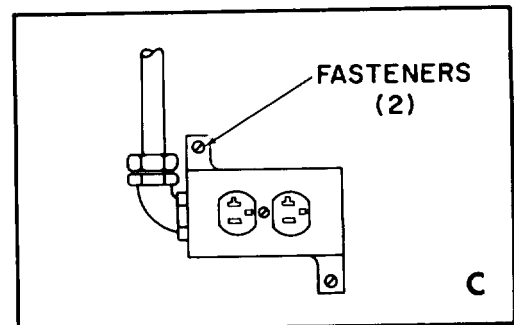
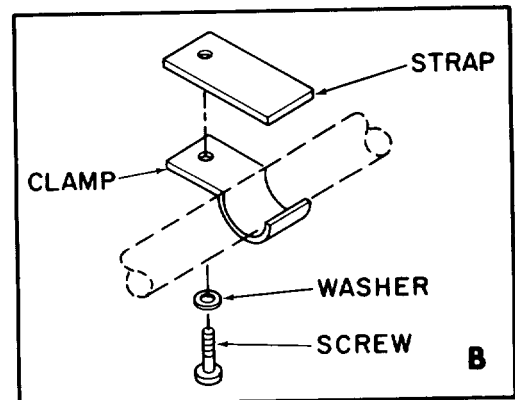
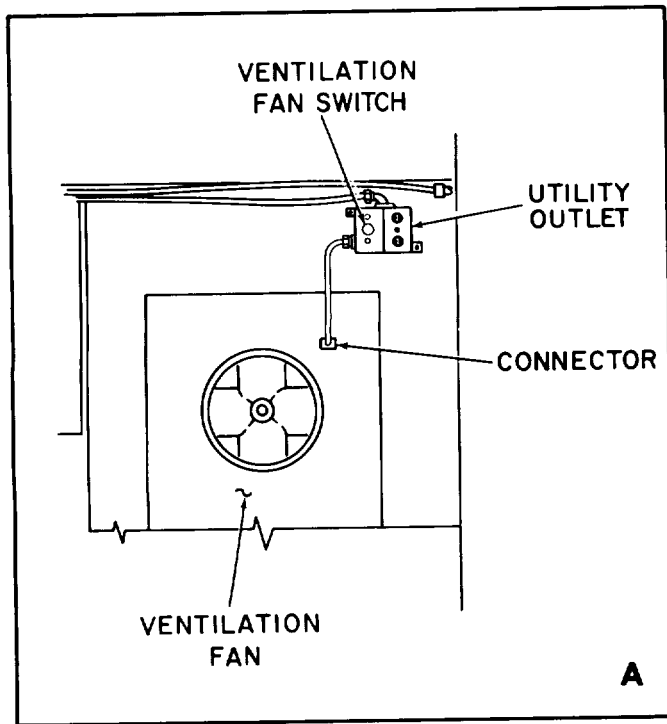
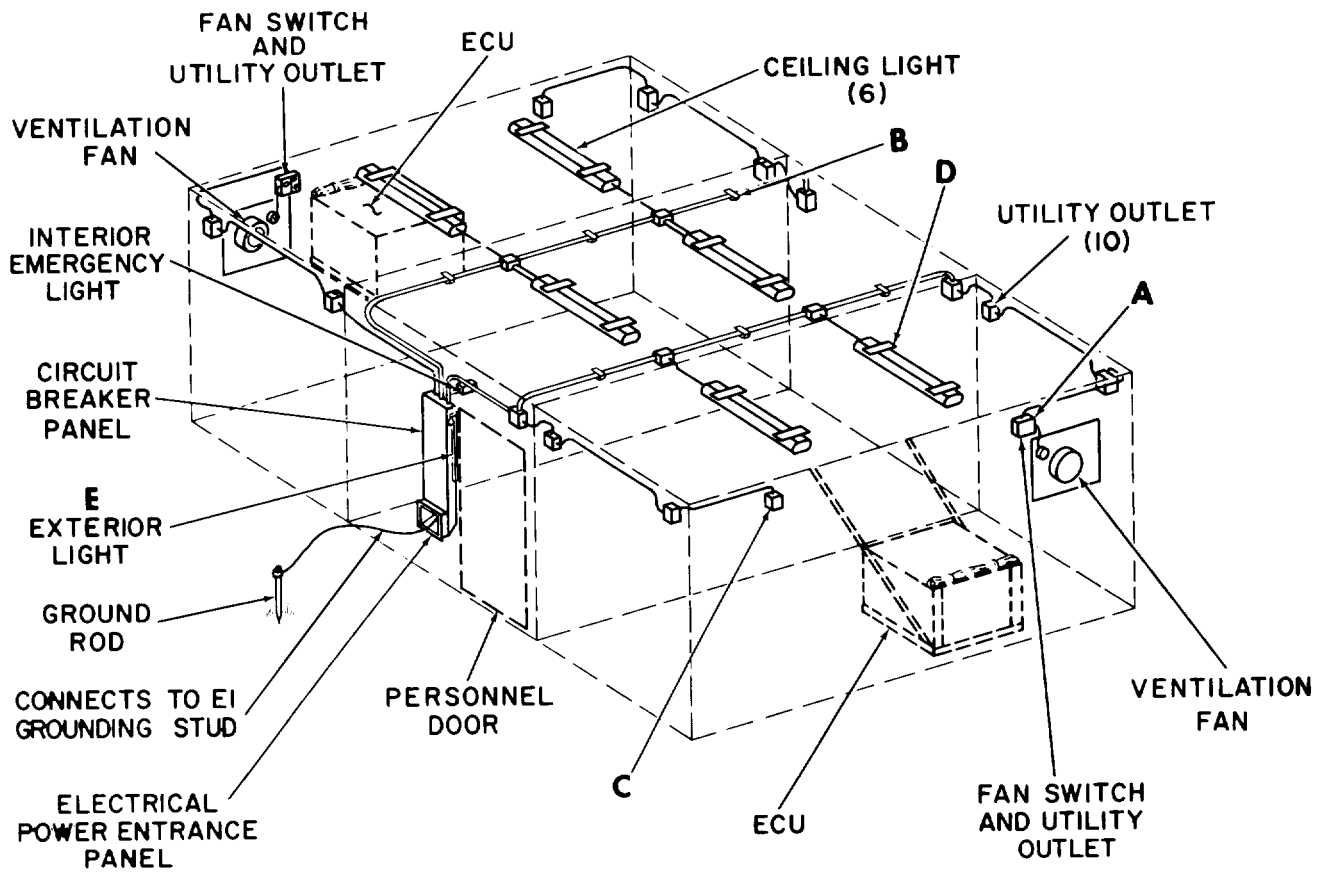

TS 023668

Figure 3-11. Electrical installation (Sheet 1 of 2)

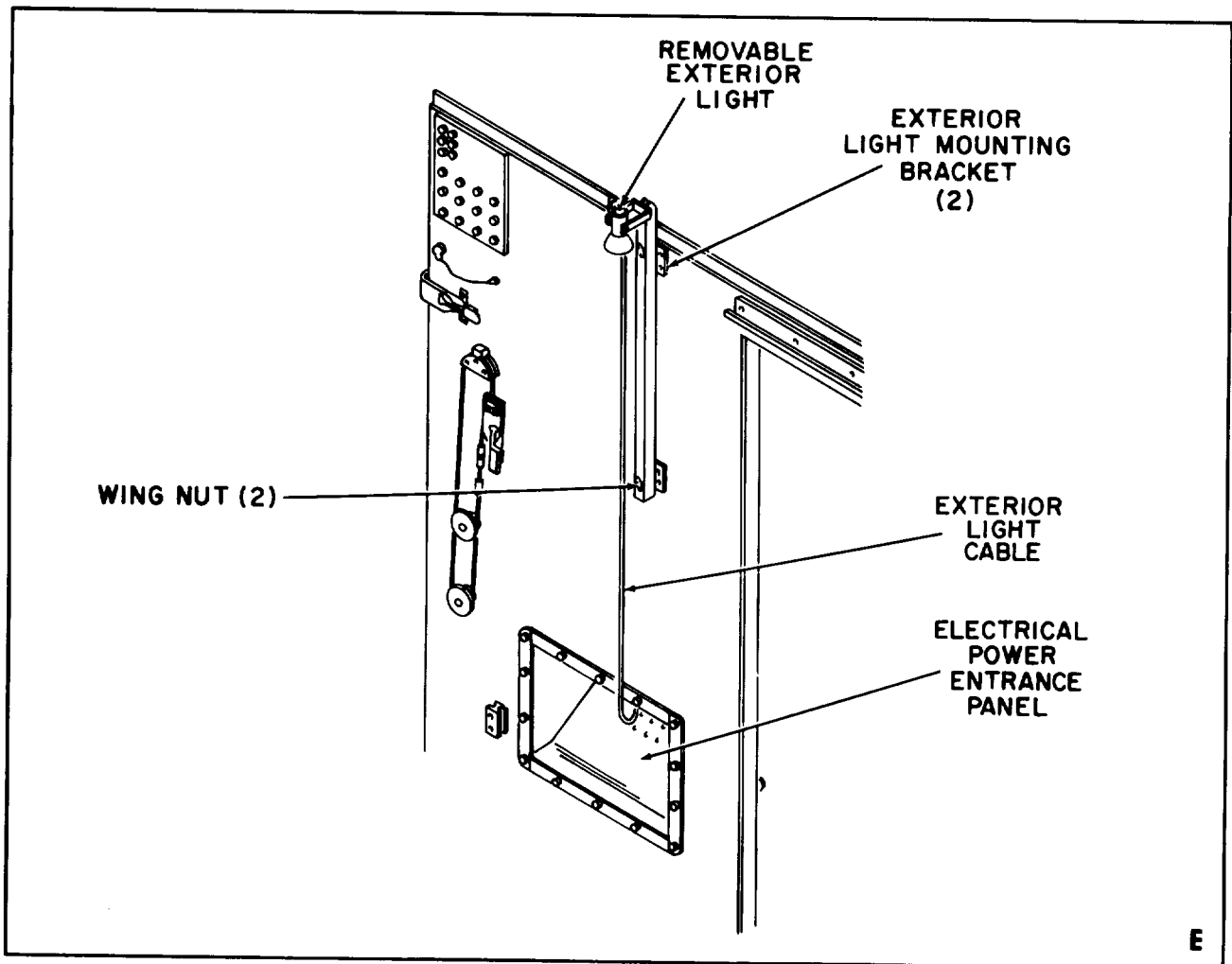
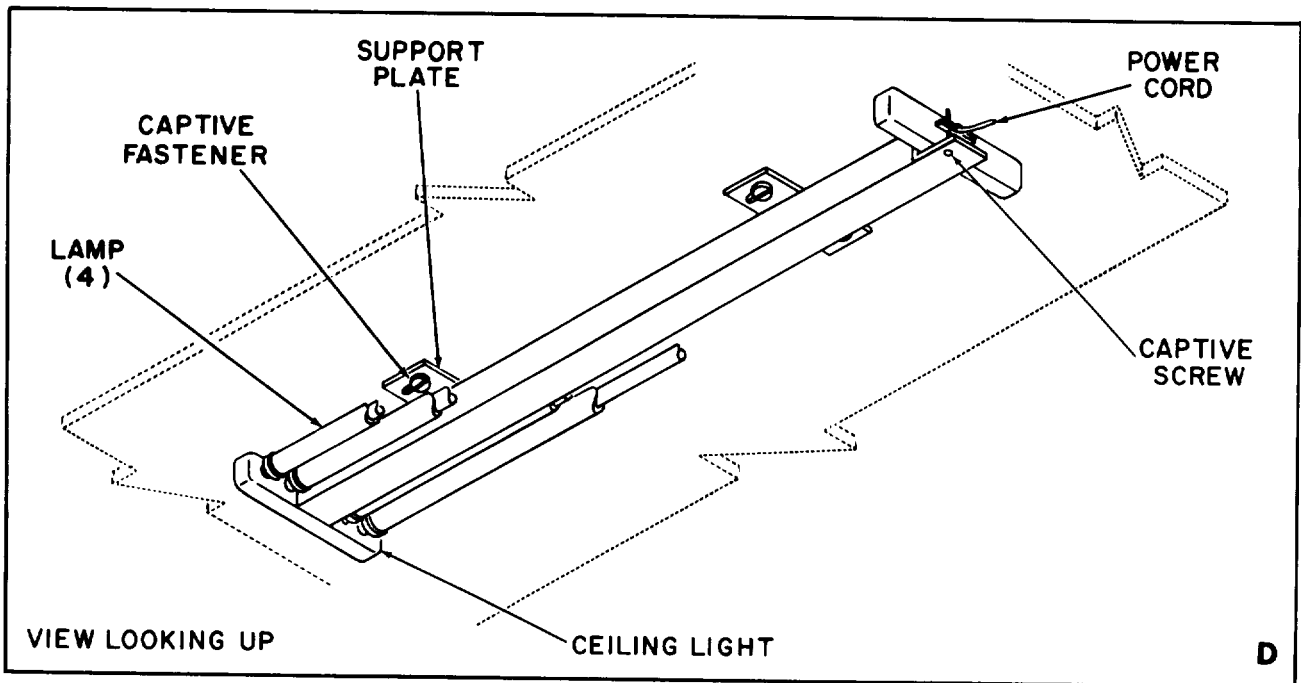

TS 023669

Figure 3-11. Electrical installation (Sheet 2 of 2)

(2) Swing holding bracket away from the light fixture.

(3) Move entire light fixture lengthwise in the direction that allows the fixture to be disengaged from the four mounting captive fasteners in ceiling.

(4) Move fixture into appropriate (left or right) shelter section and engage the four captive fasteners in the ceiling.

**NOTE**

The captive fasteners must be unscrewed to lower them in order to accommodate the light fixture.

(5) After light fixture is properly located, insert captive screw on fixture into threaded insert in ceiling to secure light fixture.

(6) Repeat steps (1) through (5) for three other ceiling light fixtures.

**NOTE**

The removable exterior light is normally attached and used at the personnel end of the shelter. However, it can also be installed at the cargo end of the shelter if necessary.

(7) Remove the exterior light from its stowage location on the inside of the cargo door (fig. 3-1) and attach it to the personnel end panel (fig. 3-11) or the cargo end panel as required.

**NOTE**

The exterior light is supplied with a 25-foot cable

so that the light can be used at the cargo end of the shelter while connected to a utility outlet on the service entrance panel at the personnel end. When used in this manner, the cable is routed over the top of the shelter. When the light is used at the personnel door, the excess cable slack should be neatly coiled so that it does not present a hazard to personnel.

(8) Connect exterior light cable connector to one of two utility outlets (J4 or J19) on the power entrance panel (fig. 3-11). If connected to J4, light can be controlled by circuit breaker CB5 on the circuit breaker panel. If connected to J19, light can be controlled by circuit breaker CB7.

e. Utility Outlet Installation. Relocate 12 utility outlets from stowage locations (fig. 3-1) to deployed positions in left and right sections of shelter (fig. 3-11).

**NOTE**

Normally, either ECU units or ventilation fans are installed in the shelter, but not both. If ECU units are to be used, install the units according to paragraph f. If ventilation fans are to be used, install according to paragraph g.

f. ECU Installation. To install the ECU's, proceed as follows:

(1) Pull out four closure plugs (fig. 3-12) from outside of ECU panel intended for location of ECU installation.

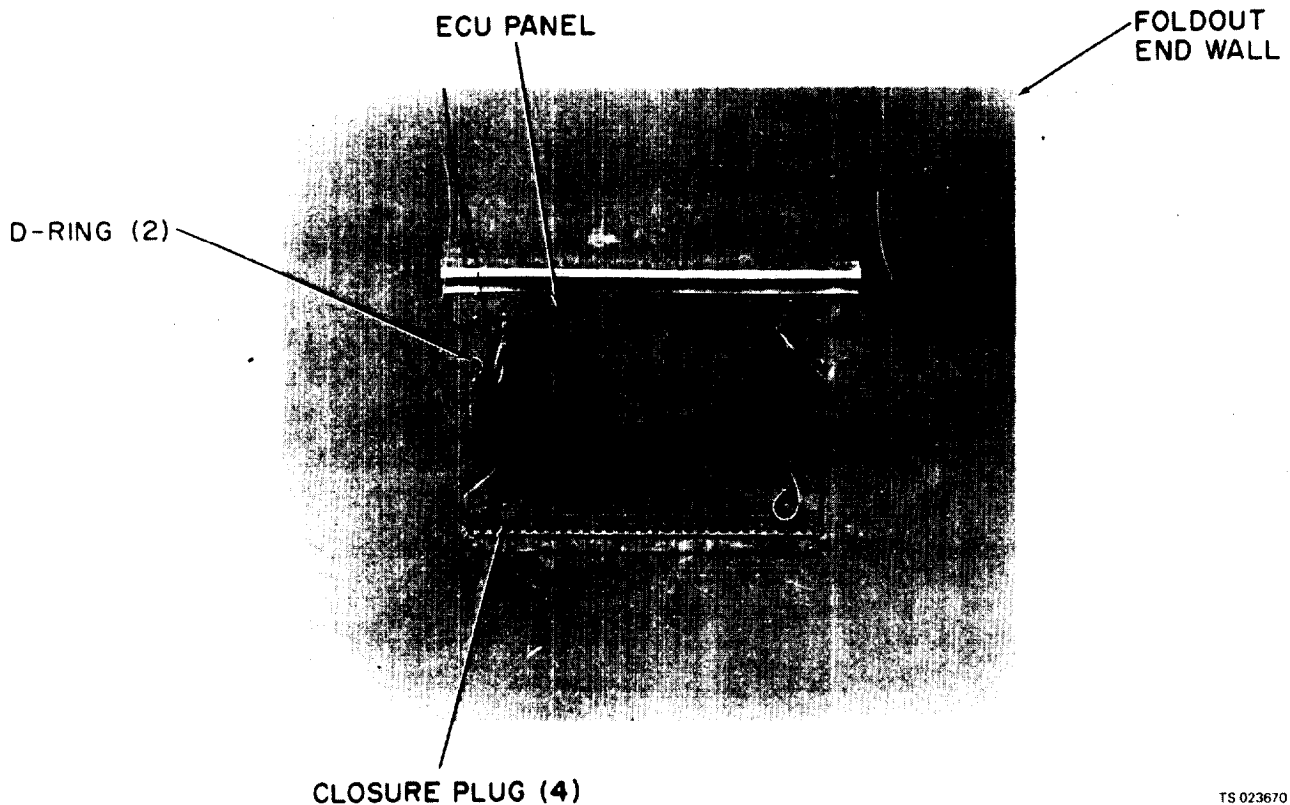

TS 023670

Figure 9-12. ECU panel in closed position

(2) Inside the shelter, loosen the two lock plates (fig. 3-13) securing the top of the ECU panel to the foldout end wall.

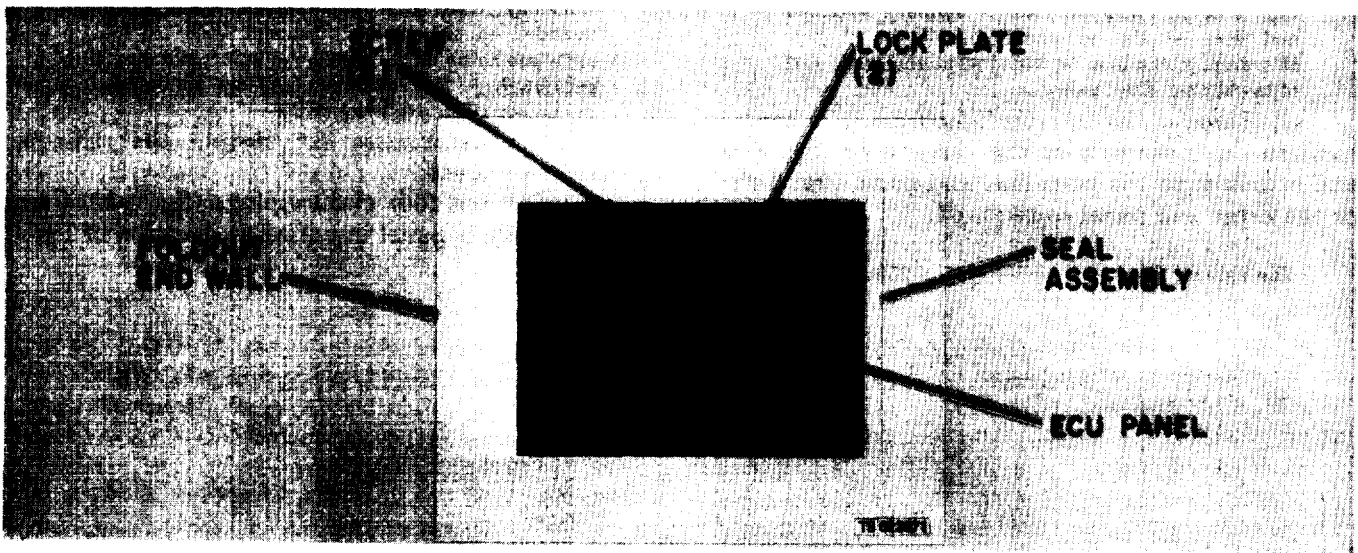
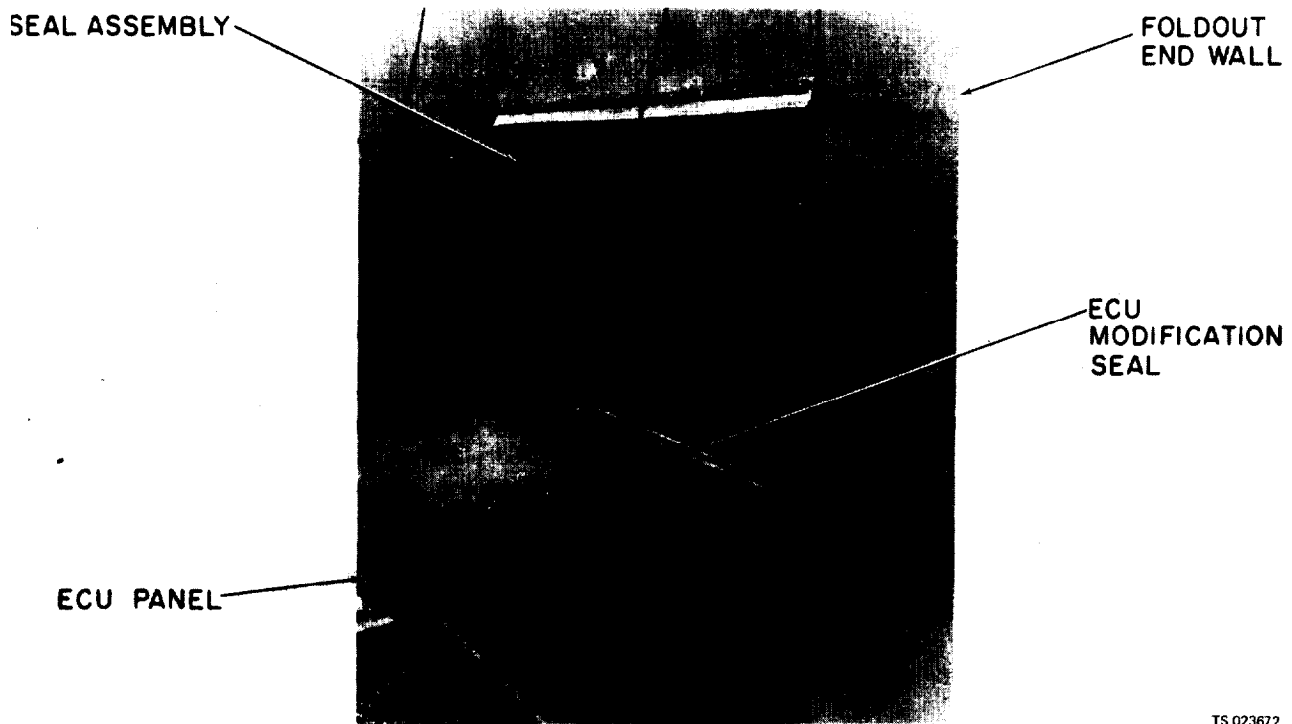

Figure 3-13. ECU panel, inside view

(3) Lower the ECU panel to form a shelf (supported by cables) on the outside of the shelter (fig. 3-14).



TS 023672

Figure 3-14. Deployment of ECU panel

(4) Remove seal assembly from the opening in foldout end wall left by the lowered ECU panel.

(5) Remove four shock mounts and bolts from bottom of ECU.

(6) Use two men to place ECU on shelf.

(7) Lift one side of ECU and slip two shock mounts provided with the ECU over the holes in shelf from which plugs were removed in step (1).

(8) Thread two bolts with sleeves and washers (provided with ECU) through the recessed holes in shelf, through the shock mounts, and into the ECU.

(9) Repeat steps (7) and (8) on other side of ECU.

(10) Put plugs removed in step (1) back into ECU panel (shelf).

(11) Inside the shelter, replace seal assembly, removed in step (4).

(12) Remove ECU modification seal from equipment chest and install along bottom of ECU.

**WARNING**

Make sure that both circuit breakers CB2 and CB3 on circuit breaker panel are in the off position before proceeding with the next step.

(13) Attach power cable to ECU (fig. 3-11). Circuit breaker CB2 and CB3 apply power to the ECU's.

(14) Repeat steps (1) through (13) for other ECU.

g. Ventilation Fan Installation. To install the ventilation fans, proceed as follows:

(1) Loosen eight thumbscrews to release clamps holding closeout panel assembly to foldout end wall selected for installation of ventilation fan (fig. 3-11).

(2) Remove closeout panel assembly.

(3) Detach ventilation fan from stowed location shown in figure 3-1. Store removed closeout panel assembly in this location.

(4) Install ventilation fan in opening and secure with eight thumbscrews and clamps.

**WARNING**

Check that fan switch located above the fan is in the OFF position.

(5) Connect cable from fan switchbox to ventilation fan.

**WARNING**

Since the input power to the shelter is lethal, this procedure must be accomplished by a qualified electrician.

(6) Connect external power cable between power source and receptacle J1 on shelter power entrance panel (see figure 2-1 and table 2-1).

(7) Repeat steps (1) through (6) for other ventilation fan.

**Section II. MOVEMENT TO A NEW WORKSITE**

**3-4. Dismantling for Movement.**

The following procedure contains the instructions for stowing the expandable shelter for movement.

**WARNING**

**The expandable shelter contains voltages that are dangerous if contacted. Before removing electrical cables or components, make certain electrical power is completely disconnected.**

- a. Turn all circuit breakers and switches on circuit breaker panel to off position.
- b. Disconnect all cabling from power entrance panel located on personnel end panel.

**WARNING**

**Removal of power cable from receptacle J1 on power entrance panel must be accomplished by a qualified electrician.**

- c. Disconnect and remove exterior light assembly from personnel end panel. Stow light assembly on inside of cargo door (see fig. 3-1).

**NOTE**

If ventilation fans are installed, follow paragraph 3-4d, steps (1) through (4) for stowage procedure for each fan. If ECU's are installed, follow paragraph 3-4e, steps (1) through (7) for each ECU.

- d. Ventilation Fan Removal. To remove the ventilation fans, proceed as follows:

- (1) Disconnect cable from ventilation fan.
- (2) Loosen eight thumbscrews to release clamps holding ventilation fan to foldout wall and remove ventilation fan.
- (3) Remove closeout panel assembly from stowage location for ventilation fan and secure ventilation fan in stowage location as shown in figure 3-1.
- (4) Replace closeout panel assembly in foldout end wall opening and secure with eight thumbscrews and clamps.

- e. ECU Removal. To remove the ECU, proceed as follows:

- (1) Remove power cable from ECU's.
- (2) Remove ECU modification seal from opening in foldout end wall and stow seal in equipment chest.
- (3) Outside shelter, remove four closure plugs from shelf (ECU panel) supporting ECU.
- (4) Remove four bolts from bottom of shelf and ECU.
- (5) Use two men to remove ECU from shelf. Attach four shock mounts using the four bolts to the bottom of the ECU.
- (6) Place the ECU in its shipping container along with shock mounts and attaching hardware.

- (7) Swing ECU panel up into closed position (fig. 3-12) and secure to shelter wall using two lock plates inside shelter (fig. 3-13).
- (8) Replace four plugs.

- f. Utility Outlet Removal. To remove utility outlets, detach 12 utility outlets from left and right section panels and walls and place in stowage position shown in figure 3-1.

- g. Light Fixture Removal. To remove light fixtures, proceed as follows:

- (1) Loosen captive screw securing ceiling light to ceiling then move entire light fixture lengthwise to disengage captive fasteners in ceiling.

- (2) Move fixture to stowage location on center structure ceiling (figure 3-1) and engage captive fasteners.

- (3) Secure ceiling light fixture by swinging holding bracket into place against fixture and lock in place using ball-lock pin,

- (4) Tighten the four captive fasteners flush with the ceiling.

- (5) Repeat steps (1) through (4) for three other ceiling lights.

- h. Ground Rod Removal. Disconnect ground cable from ground stud E1 on power entrance panel and remove ground rod from earth. Stow ground rod in equipment chest.

- i. Ground Anchor Removal. Disconnect and remove all tie down anchors and cables. Remove tie down rings from expanded sections of shelter and stow in equipment chest.

**CAUTION**

**Position cables so they will not be caught in panel hinges when walls are folded. Make sure that struts are properly positioned so that they are in a perfectly vertical position and not bent or twisted.**

- j. Preparing Shelter for Moving. To prepare shelter for moving, proceed as follows:

- (1) Unpin roof support struts from stowed position on one side of expandable shelter and place them in position to support foldout roof panel.

- (2) Release latches securing safety cables to personnel and cargo end panels.

- (3) Remove jacks from corners of sections being folded, and stow jacks on inside of personnel and cargo end panels. (See fig. 3-1.)

**WARNING**

**The folding roof section weighs approximately 375 pounds. Four men are required to fold shelter for shipment. When folding expandable shelter in high winds, be sure to have at least two men**



guide each foldout and swingout wall, floor, and roof into place. Serious injury can result from free-swinging units.

(4) Release inside and outside latches securing foldout roof panel to swingout walls and foldout end wall. Using roof support struts (fig. 3-9), raise and support foldout roof panel about two inches for clearance.

(5) Release latches securing foldout end wall end foldout floor panel to swingout walls. Rest foldout end wall against roof support struts and place all latches in stowed position.

**WARNING**

Support foldout end wall to keep it from falling while swingout walls are folded.

**CAUTION**

**The shelter is designed for temperatures between  $-25^{\circ}\text{F}$  ( $-31.7^{\circ}\text{C}$ ) and  $+125^{\circ}\text{F}$  ( $51.7^{\circ}\text{C}$ ). However, when temperature is approximately  $0^{\circ}\text{F}$  ( $-17.8^{\circ}\text{C}$ ) or lower, use extreme care when unfolding end walls and swingout walls. Since electrical cables can be brittle at these low temperatures, the walls should be folded out slowly and carefully. If possible, warm shelter before stowing cables.**

(6) Rotate right swingout wall into stowed position (fig. 3-6) in center structure, then rotate left swingout wall to stowed position. Right and left are determined from the outside of the shelter, facing the sides being folded. Use ball-lock pins (fig. 3-8) to secure swingout walls and adjust nuts on ball-lock pins to secure swingout walls tightly against the stops.

**WARNING**

Floor and wall weigh approximately 375 pounds.

If high winds exist, at least two men must guide each swingout wall into position and hold it until it is secured.

**CAUTION**

Ensure that the two hinged D-rings (fig. 3-12) on the ECU panels are in a flat position.

(7) Fold foldout end wall to foldout floor panel and insure D rings are in flat position. Raise floor panel to stowed position (fig. 3-5). When foldout floor panel is in fully folded position, disconnect safety cables (fig. 3-7) from floor. Secure safety cables to end panels using latches (fig. 3-2). Physically move the floor to check that the spring-loaded pins are engaged. Pins should be flush in.

**WARNING**

**Hinged roof section weighs 150 pounds.**

(8) Lower hinged roof panel (fig. 3-5), and place roof support struts in stowed position (fig. 3-3).

(9) Secure foldout roof panel using latches.

(10) Repeat steps (2) through (9) for opposite end of shelter.

(11) Lower the shelter to the ground and remove four jacks supporting center structure. Place jacks in stowage on inside of center structure. (see fig. 3-1.)

(12) Place equipment on center of floor of center structure and secure using tie-down straps.

**3-5. Reinstallation After Movement.**

To reinstall the expandable shelter after movement, perform the procedures in paragraphs 3-1 through 3-3.

**Section III. ORGANIZATIONAL MAINTENANCE REPAIR PARTS, SPECIAL TOOLS AND EQUIPMENT**

**3-6. Organizational Maintenance Tools and Equipment.**

The tools and equipment issued for organizational maintenance of the expandable shelter are listed in Section II of Appendix B (Maintenance Allocation Chart) of this manual.

**3-7. Organizational Maintenance Special Tools and Equipment.**

The special tools and equipment required for

organizational maintenance of the expandable shelter are listed in TM 10-5410-224-24P (Repair Parts and Special Tools List).

**3-8. Organizational Maintenance Repair Parts.**

Repair parts and equipment required for organizational maintenance of the expandable shelter are contained in TM 10-5410-224-24P (Repair Parts and Special Tools List).

**Section IV. LUBRICATION INSTRUCTIONS**

**3-9. General.**

The only lubrication required for the expandable shelter is the quarterly lubrication of the leveling jacks. The procedure for lubricating the leveling jacks is given in the following paragraph.

**3-10. Leveling Jack Lubrication.**

The leveling jack must be lubricated every 90

days or sooner if extremely dry or dusty weather conditions exist. The lubricant to be used is grease MIL-G-23827 and is applied to the grease fitting on the jack by means of a grease gun.

**Section V. OPERATOR AND ORGANIZATIONAL PREVENTIVE MAINTENANCE CHECKS AND SERVICES**

**3-11. General.**

To ensure that the expandable shelter (deployed mode) is ready for operation at all times, it must be inspected systematically so that defects may be discovered and corrected before they result in serious damage or failure. The necessary preventive maintenance services to be performed are listed and described in paragraph 3-12. Item numbers indicate the sequence of and minimum inspection required. Defects discovered during operation of the equipment should be noted for future correction to be made as soon as operation has ceased. Stop operation immediately, if a deficiency is noted during operation which would damage the equipment. Record all deficiencies,

together with the corrective action taken, in accordance with TM 38-750.

**3-12. Operator and Organizational Preventive Maintenance Checks and Services.**

The operator and organizational preventive maintenance checks and services are contained in tables 3-2 and 3-3, respectively. Each table is a tabulated listing of preventive maintenance checks and services which must be performed at the specified intervals to ensure that the equipment will perform satisfactorily until the next periodic service. The item numbers are listed consecutively in a systematic sequence.

D. Doily Table 3-2. Operator Preventive Maintenance Checks and Services W-Weekly

Interval and Sequence No.		Item to be Inspected Procedure
D	w	
1		OVERALL EQUIPMENT Check that expandable shelter is complete and properly positioned for use.
2		CLEANLINESS AND CONDITION OF EQUIPMENT Check interior and exterior of expandable shelter for overall cleanliness, general condition, and obvious damage. Use a clean, soft-bristle brush to remove dust, dirt, and lint from all parts and surfaces. Clean walls with soap and water, and a sponge or soft cloth. Clean floors by scrubbing with soap, clean water, and a mop.
3		ELECTRICAL SYSTEM OF EQUIPMENT Check that electrical cables are properly connected and check for proper position of all circuit breakers

M-Monthly Table 3-3. Organizational Preventive Maintenance Checks and Services Q-Quarterly

Interval and Sequence No.		Item to be Inspected Procedure
M	Q	
1		SWINGOUT WALLS Check that all seals are secure. Inspect surface for damage and corrosion, Check latches for damage and for ease of operation.

Table 3-3. Organizational Preventive Maintenance Checks and Services – Continued

M-Monthly

Q-Quarterly

Interval and Sequence No.		Item to be Inspected Procedure
M	Q	
2		<b>FOLDOUT ROOF AND FLOOR PANELS</b> Check that all seals are secure. Check hinges and fasteners for damage and ease of operation. Inspect surface for damage.
3		<b>FOLDOUT END WALLS</b> Check that all seals are secure. Check fan panel assembly. Check hinges and latches for damage and for ease of operation. Inspect surface for damage.
4		<b>PERSONNEL AND CARGO END PANELS</b> Check that all seals are secure. Check operation and condition of exterior light, Inspect surface for damage. Check safety cables and latches. Check lifting and towing eyes for condition and security.
5		<b>PERSONNEL AND CARGO DOORS</b> Check security and condition of door hinges. Check operation and security of door handles and linkage. Check doors for proper sealing. Inspect door surface and vents for damage. Check security of steps to roof.
6		<b>CENTER STRUCTURE ROOF AND FLOOR PANELS</b> Check that all seals are secure. Inspect surface for damage. Check roof drop pad. Check roof handle and plate.
7		<b>POWER ENTRANCE PANEL</b> Check condition of electrical connectors. Check for presence of dirt, rust, or <i>corrosion</i> . Check for condition of grounding stud.
8		<b>LEVELING JACKS</b> Check for mounting and general security of jacks. Lubricate jack screw in accordance with MIL-G-23827. Check that ratchet operates freely.
9		<b>ECU INSTALLATION KIT AND SHELTER REPAIR KIT</b> Check for completeness and general condition.
10		<b>COMPLETE SHELTER</b> Check that expandable shelter is level. Check that modifications have not been made that prevent complete shelter deployment or stowage. Check that ECU's are properly <i>installed</i> . Check all markers for legibility.
11		<b>SHELTER INTERIOR</b> Check shelter floors, walls, and ceiling for general condition and security. Check electrical wiring, receptacles, and outlets for security of attachment and condition. Check ventilation fans for proper installation, general condition, and operation. Check ceiling lights and receptacles for proper installation, general condition, and operation.
12		<b>CIRCUIT BREAKER PANEL</b> Check circuit breakers and switches for security of attachment and proper mechanical operation. Check general conditions of structure and door. Check condition of wires and connections.

**Section VI. ORGANIZATIONAL MAINTENANCE TROUBLESHOOTING**

**3-13. General.**

This section contains organizational maintenance troubleshooting information for locating and correcting most of the operating troubles which may develop in the expandable shelter.

**WARNING**

The expandable shelter contains voltages that are dangerous if contacted. Take appropriate precautions when troubleshooting. Before performing continuity checks or replacing electrical components, make certain electrical power is completely disconnected from the circuit involved.

**3-14. Troubleshooting Table.**

a. Each malfunction for an individual component, unit, or system is listed in troubleshooting table 3-4. The malfunction is followed by a list of

tests or inspections which help to determine probable causes and corrective actions to take. The tests or inspections and corrective actions are to be performed in the order listed in the table.

b. All malfunctions that occur, tests or inspections, and corrective actions cannot be listed in table 3-4. If a malfunction is not listed or is not corrected by listed corrective actions, the appropriate supervisory personnel should be notified.

c. Unless otherwise noted, when troubleshooting the operation of the expandable shelter, the switches, controls, and circuit breakers must be placed in proper operating positions and power must be properly connected.

**NOTE**

Unless otherwise noted, all circuit breakers and switches called out in troubleshooting table 3-4 are located on circuit breaker panel.

Table 3-4. Organizational Maintenance Troubleshooting

MALFUNCTION	TEST OR INSPECTION	CORRECTIVE ACTION
<b>SHELTER POWER</b>		
<b>NO POWER IS DISTRIBUTED WITHIN THE EXPANDABLE SHELTER.</b>		
	<i>Step 1.</i>	Check that outside power is properly connected to connector J1 on power entrance panel, and check general condition of cable and connector. Make proper power connection and replace defective item (para 3-26).
	<i>Step 2.</i>	Check main circuit breaker CB1. Refer to direct support maintenance shop personnel.
<b>LIGHT FIXTURES</b>		
<b>ONE OR BOTH RIGHT CEILING LIGHTS FAIL TO COME ON.</b>		
	<i>Step 1.</i>	Check for burned out bulb. Replace bulb (para 3-27).
	<i>Step 2.</i>	Check associated cables and receptacles for defects. Replace defective item (para 3-27).
	<i>Step 3.</i>	Check associated circuit breaker CB4 and switch S1. Refer to direct support maintenance shop personnel.
<b>ONE OR BOTH CENTER STRUCTURE CEILING LIGHTS FAIL TO COME ON.</b>		
	<i>Step 1.</i>	Check for burned out bulb. Replace bulb (para. 3-27).
	<i>Step 2.</i>	Check associated cables and receptacles for defects. Replace defective item (para. 3-27).
	<i>Step 3.</i>	Check associated circuit breaker CB6 and switch S2. Refer to direct support maintenance shop personnel.
<b>ONE OR BOTH LEFT CEILING LIGHTS FAIL TO COME ON.</b>		
	<i>Step 1.</i>	Check for burned out bulb. Replace bulb (para. 3-27).
	<i>Step 2.</i>	Check associated cables and receptacles for defects. Replace defective item (para. 3-27).
	<i>Step 3.</i>	Check associated circuit breaker CB8 and switch S3. Refer to direct support maintenance shop personnel.
<b>EMERGENCY INTERIOR LIGHT FAILS TO COME ON.</b>		
	<i>Step 1.</i>	Check for burned out bulb. Replace bulb (para. 3-27).
	<i>Step 2.</i>	Check associated cable and receptacle for defects. Replace defective item (para. 3-27).
	<i>Step 3.</i>	Check associated circuit breaker CB9 and switch S4. Refer to direct support maintenance shop personnel.
<b>RECEPTACLES AND UTILITY OUTLETS</b>		
<b>NO POWER AT ONE OF THE ECU RECEPTACLES.</b>		
	<i>Step 1.</i>	Check associated cable and receptacle for defects. Replace defective item (para. 3-26).
	<i>Step 2.</i>	Check associated circuit breaker CB2 or CB3. Refer to direct support maintenance shop personnel.
<b>NO POWER AT ONE OR MORE UTILITY OUTLETS.</b>		
	<i>Step 1.</i>	Check associated cables and outlet assemblies for defects. Replace defective item (para. 3-26).
	<i>Step 2.</i>	Check associated circuit breakers, CB10, CB11, CB12, or CB13. Refer to direct support maintenance shop personnel.
<b>NO POWER AT ONE OF THE EXTERIOR OUTLETS.</b>		
	<i>Step 1.</i>	Check associated cable and outlet assembly for defects. Replace defective item (para. 3-26).
	<i>Step 2.</i>	Check associated circuit breaker CB5 or CB7. Refer to direct support maintenance shop personnel.
<b>VENTILATION FANS</b>		
<b>ONE OR BOTH VENTILATION FANS FAIL TO OPERATE.</b>		
	<i>Step 1.</i>	Check associated cables and receptacles for defects. Replace defective item (para. 3-26).
	<i>Step 2.</i>	Check associated circuit breaker CB14, and associated switches S5 and S6 (mounted above and to the right of associated fan). If circuit breaker CB14 is defective, refer to direct support maintenance shop personnel. If switch S5 or S6 is defective, replace defective switch (para. 3-28).
	<i>Step 3.</i>	Check associated motors B1 and B2. Repair or replace defective motor (para. 3-28).

**Section VII. MAINTENANCE OF SHELTER BODY**

**3-15. General.**

The components that make up the shelter body are the swingout walls panels, foldout end walls, foldout roof panels, foldout floor panels, personnel and cargo end panels, center structure roof and floor panels, and leveling jack assemblies. This section contains the inspection, cleaning, and repair of the shelter body.

**3-16. Shelter Body Repair.**

The following paragraphs contain the necessary information for making involved minor repairs to the shelter body covered under organizational maintenance. Simple minor repairs can be accomplished using procedures given herein. Major repairs are accomplished under direct and general support maintenance. The special tools required for

repair are listed in TM 10-5410-224-24P, Repair Parts and Special Tools List. The materials required for repair are listed in table 3-5.

a. **Drying Out Water-Soaked Areas in Panels.** Care must be taken to prevent water from entering the core material, since it is very difficult to remove. When damage occurs, the punctured face sheet must be temporarily protected or sealed to prevent entry of water until a proper repair can be made. If water has been allowed to enter the panel, it should be repaired immediately as follows:

(1) Position heat lamps around the cut-out area. Adjust lamps so that panel surface temperature does not exceed 150°F. (66°C).

(2) Allow heat lamps to remain in position until the damaged area and surrounding core material are thoroughly dry.

Table 3-5. Repair Materials

Material	Part No.	Manufacturer	Use
Sealant	RTV-732	MIL-A-46106	Minor seal repairs
Caulking cartridges (2)			For application of sealant
Sealant	PR-1422	MIL-S-8802	Minor seal repairs
Rivet (100)	1601-0619	Avdel Corp.	Installing patches and general repairs
Rivet (100)	1601-0613	Avdel Corp.	Installing patches and general repairs
Rivet (100)	1601-0414	Avdel Corp.	Installing patches and general repairs
Rivet (100)	1601-0410	Avdel Corp.	Installing patches end general repairs
Tape, marking	1" wide		General use
Adhesive	FE 6026 Part A	Fuller H. B. Co.	Installing inserts
Adhesive	FE 6026 Part B	Fuller H. B. Co.	Installing inserts
Tape	2" wide x 60' long (green)		General repair
Anti skid covering	Durapox II (dark grey)	Palmer Products Co. Inc.	Floor covering repair
Aluminum alloy patches	0.040" thick X 12" x 12"		Patching
Nomex core	3-1/2" thick x 10" ± 1" x 14" ±	Hexcel Corp.	Patching
Nomex core	2" thick X 24" ± 3" x 24" ± 3"	Hexcel Corp.	Patching
Nomex core	1-1/4" thick X 24" ± 3" x 24" ± 3"	Hexcel Corp.	Patching
Canvas bag	Olive drab (30" x 30" x 12")		Storing repair parts
Adhesive	BMS200067		Potting

**NOTE**

When dry, the core material will feel hard and brittle. The drying time will vary, depending on the amount of moisture in the panel. Drying time must be determined by experience and the extent of the water in the panel.

(3) After the damaged area is thoroughly dried, the panel is repaired in accordance with the

applicable repair procedures in the following paragraphs.

b. **Repairing Minor Panel Damage Where Face Sheet Is Not Cracked.** (See fig. 3-15). The following procedure is used for repairing small dents or gouges in the panel face sheet, where the face sheet is not cracked.

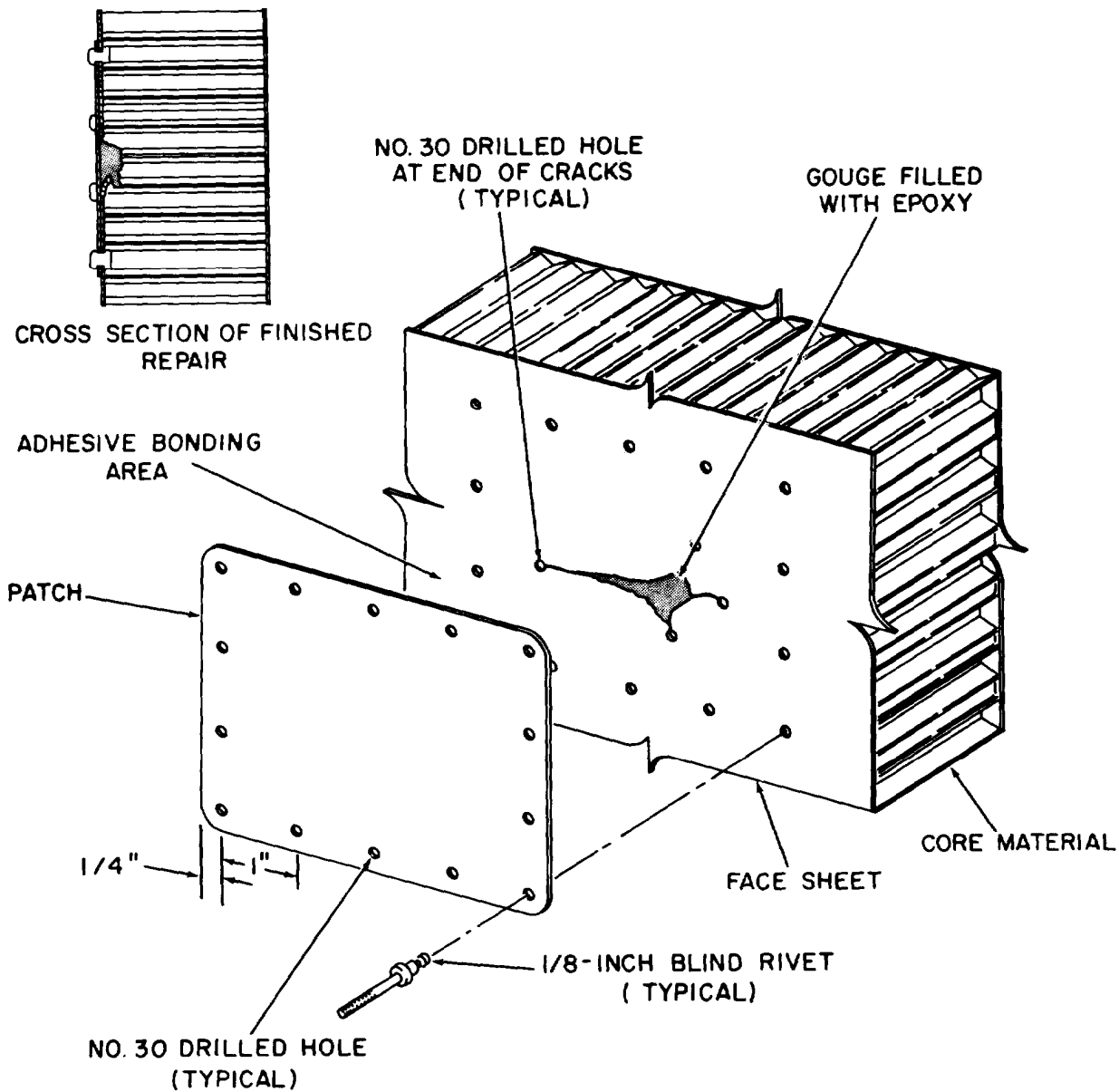

TS 023673

Figure 3-15. Repairing minor panel damage

(1) Sand damage area with sand paper to remove all traces of paint.

**WARNING**

Methylethyl ketone is flammable and toxic and must be used only in a well-ventilated area away from all sparks or open flames.

(2) Wipe surface with a cloth dampened in methylethyl ketone and immediately wipe solvent from surface with a clean, dry cloth.

(3) Mix a small quantity of epoxy filler.

(4) Fill in damaged area with epoxy, using spatula or putty knife. Allow epoxy to cure fully.

(5) Sand surface of the cured epoxy to conform to surrounding area.

(6) Paint repaired area in accordance with subparagraph 3-16h.

c. Repairing Minor Panel Damage Where Face Sheet Is Surrounded By Extended Cracks. (See fig. 3-15). The following procedure is used for repairing small dents or gouges in the panel face

sheet, where the face sheet is surrounded by cracks.

- (1) Stop-drill all cracks, using a No. 30 drill.
- (2) Sand damage area with sand paper to remove all traces of paint. Remove paint for a distance of 1-1/4 inches all around damage.
- (3) Cut a rectangular patch one inch larger all around than damage area. Make patch same thickness as a panel face sheet.
- (4) Lay out hole pattern in patch. Use 1/4-inch edge distance and 1-inch spacing. Drill holes, using No. 30 drill.
- (5) Center patch over damaged area and drill through face sheet, using prechilled holes in patch as a guide.
- (6) Remove patch, and remove burrs from all drilled holes.
- (7) Prepare bonding surfaces of face sheet and patch for bonding by sanding until oxide film is removed.

#### **WARNING**

Bring no more methylethyl ketone into area than is needed.

- (8) Wipe surface with a cloth soaked in methylethyl ketone and immediately wipe solvent from surface with a clean cloth. Wear gloves to avoid contaminating the cleaned surfaces with dirt, oil or fingerprints.
- (9) Mix sufficient quantity of epoxy for the repair. Place epoxy in damaged area and let cure.
- (10) Apply a thin, even coat of sealing compound, MIL-S-8802, to bonding surfaces of face sheet and patch.
- (11) Secure patch to face sheet using 1/8-inch sheet fasteners.
- (12) Dip rivets in sealing compound, MIL-S-8802.
- (13) Install 1/8-inch universal head blind rivets in all drilled holes.
- (14) After installation cover rivets with sealing compounds.
- (15) Remove any excess epoxy from outer surfaces of repair.
- (16) After the repair has cured, caulk edges of patch in accordance with paragraph 3-16f. and paint repaired surfaces in accordance with paragraph 3-16h.

d. Repairing Both Panel Faces. The following procedure is used for repairing damage that extends through both panel faces.

- (1) Clean protruding metal or damage core from hole.
- (2) If practical, fill hole with epoxy filler and rivet patch on each face of panel.
- (3) If cut is too large to fill, make temporary repair by installing double patch to both surfaces without the filler. Use procedures of paragraph 3-16c for installing patches.

e. Replacing shelter seals. The following procedure is recommended for replacing any shelter seal.

- (1) Remove defective seal.
- (2) Strip off old sealant from structure.
- (3) Clean bonding surface with sand paper.

#### **CAUTION**

Seals must not be washed with any aromatic hydrocarbon (such as benzene, toluene, and xylene).

(4) Clean seal and bonding surface to which it is to be attached, using a clean cloth dampened in acetone. Dry immediately with a clean cloth.

(5) Mix adhesive FE 6026 Parts A and B according to the manufacturer's instructions. Brush on bonding surface to which seal will be attached.

(6) Within ten minutes after application of sealant, place seal in position and immediately smooth sealant.

#### **NOTE**

If seal is the type that is to be riveted to aluminum retaining strip, dip rivets in sealing compound MI L-S-8802. After installation rivets, cover rivets and seal with sealing compound.

(7) Clamp in place overnight, using sufficient pressure to ensure firm contact without distorting shape of seal. Overnight curing will provide holding strength; full strength will be attained after seven days.

f. Caulking Repaired Areas. After a repair to the expandable shelter structure has been completed, it must be caulked to seal out water and moisture. Sealant, MIL-S-8802 is used for caulking repaired areas and under fasteners. This is a two-part material consisting of a Thiokol base and an accelerator. Nominal pot life of this compound is 8 hours; nominal curing time is 140 hours. The following general procedure is recommended for mixing and applying the compounds.

#### **NOTE**

Caulking under/around fasteners (rivets, screws, bolts, etc.) is also a requirement at their installation.

The sealant is furnished in kit form and may be mixed in the can containing the Thiokol. Mixing ratio is as specified on the can by the manufacturer.

- (1) Stir the accelerator to a smooth, creamy paste, using a spatula or putty knife.
- (2) Mix the accelerator into the compound and stir thoroughly until no streaks of accelerator or unmixed compound are visible. Mix the material thoroughly at sides and bottom of can. Thorough mixing requires at least 5 minutes.
- (3) After mixing is completed, the sealant is applied, using a caulking gun, spatula, hypodermic syringe, or putty knife.

(4) Thoroughly clean surfaces to be caulked by wiping with a cloth dampened in solvent.

(5) Apply sealant in 1/8-inch minimum fillet.

g. Corrosion Removal. Before a corroded area can be refinished, the corrosion must be removed by such means as wire brushing (with corrosion-resistant wire brush), sanding, abrasive blasting, or application of corrosion-removing compounds. The affected area must be free of dust, residue, and cleaning compounds before refinishing. Refer to following paragraph for paint refinishing instructions.

h. Paint Refinishing. Primers and paints used for refinishing painted surfaces of the expandable shelter are listed in table 3-6. The following general procedure is recommended for refinishing.

**WARNING**

Paints are flammable. Use in a well-ventilated area and remove all sources of possible ignition.

(1) Thoroughly clean surface to be painted.

Remove all traces of dirt, oil, corrosion, and loose paint.

(2) If the surface to be painted is bare aluminum, apply conversion coating first. In the case of ferrous parts, apply metal conditioner, Specification MIL-M-10578. Allow coatings to dry thoroughly before applying primer.

**NOTE**

Drying times for primers and paints vary according to temperature and humidity.

(3) Mix and apply a uniform coat of primer in accordance with MIL-C-22751D.

**NOTE**

Allow primer to dry thoroughly before applying finish coat.

(4) Mix and apply two separate, uniform coats of finish coat, making certain there are no sags or runs. Be sure first coat is dry before applying second coat.

**3-17. Swingout Walls.**

a. General. There are four swingout walls contained in the expandable shelter. When these walls are fully unfolded into position, they form the four left and right end panels of the deployed shelter. The following paragraphs contain inspection and repair information for the swingout walls.

b. Inspection. Check that all seals are secure. Inspect surface for damage and corrosion. Check latches for damage and ease of operation.

c. Repair. Refer to shelter body repair instructions given in paragraph 3-16.

Table 3-6. Paint Data

Use	Type and Specification
Interior and exterior panel surfaces and metal parts primer	Epoxy Polyamide, MIL-P-23377,
Interior walls and ceilings finish coat	Lacquer, Semigloss, MIL-L-52043, Color, White, Fed Std 27875
Floor finish coat	Durapox Type II Anti-Skid Covering, Gray
Exterior panel surfaces and metal parts finish coat	Enamel Alkyd, Camouflage, Forest Green, MIL-E-52798

**3-18. Foldout End Walls.**

a. General. There are two foldout end walls contained in the expandable shelter. When these end walls are fully unfolded into position, they form the left and right end walls of the deployed shelter. The following paragraphs contain inspection and repair information for the foldout end walls.

b. Inspection. Check that all seals are secure. Check fan panel assembly. Check hinges and fasteners for damage and ease of operation. Inspect surface for damage.

c. Repair. Refer to shelter body repair instructions given in paragraph 3-16.

**3-19. Foldout Roof Panels.**

a. General. There are two foldout roof panels contained in the expandable shelter. When these roof panels are fully unfolded into position, they form the left and right side roof section of the deployed shelter. The following paragraphs contain inspection and repair information for the foldout roof panels.

b. Inspection. Check that all seals are secure. Check hinges and fasteners for damage and ease of operation. Inspect surface for damage.

c. Repair. Refer to shelter body repair instructions given in paragraph 3-16.

**3-20. Foldout Floor Panels.**

a. General. There are two foldout floor panels contained in the expandable shelter. When these floor panels are fully unfolded and into position, they form the left and right side floor sections of the deployed shelter. The following paragraphs contain inspection and repair information for the foldout floor panels.

b. Inspection. Check that all seals are secure. Check hinges and fasteners for damage and ease of operation. Inspect surface for damage.

c. Repair. Refer to shelter body repair instructions given in paragraph 3-16.



**3-21. Personnel and Cargo End Panels.**

*a. General.* There is a fixed personnel end panel and a fixed cargo end panel contained in the expandable shelter center structure. The two end panels contain doors which provide entrances for personnel and cargo. The following paragraphs contain inspection and repair information for the personnel and cargo end panels.

*b. Inspection.* Check that all seals are secure. Check operation and condition of exterior light. Inspect surface for damage. Check safety cables and latches. Check lifting and towing eyes for condition and security. Check security and condition of door hinges. Check operation and security of door handles and linkage. Check doors for proper sealing. Inspect door surface and vents for damage. Check security of steps to roof.

*c. Repair.* Repair procedures for the personnel end panel and cargo end panel consist of shelter

body repair instructions given in paragraph 3-16 and procedures for the removal and replacement of particular items attached to the end panels. The removal and replacement procedures are given in the following subparagraphs.

(1) Removal and replacement of personnel end panel jack support plate (fig. 3-16). To remove and replace jack support plate (18), proceed as follows:

(a) Remove jack from jack support plate (18).

(b) Remove two screws (16) and washers (17) to detach jack support plate (18) and spacer (19).

(c) Replace jack support plate and spacer by securing to personnel end panel with two screws (16) and washers (17).

(d) Install jack in accordance with paragraph 3-3a(3).

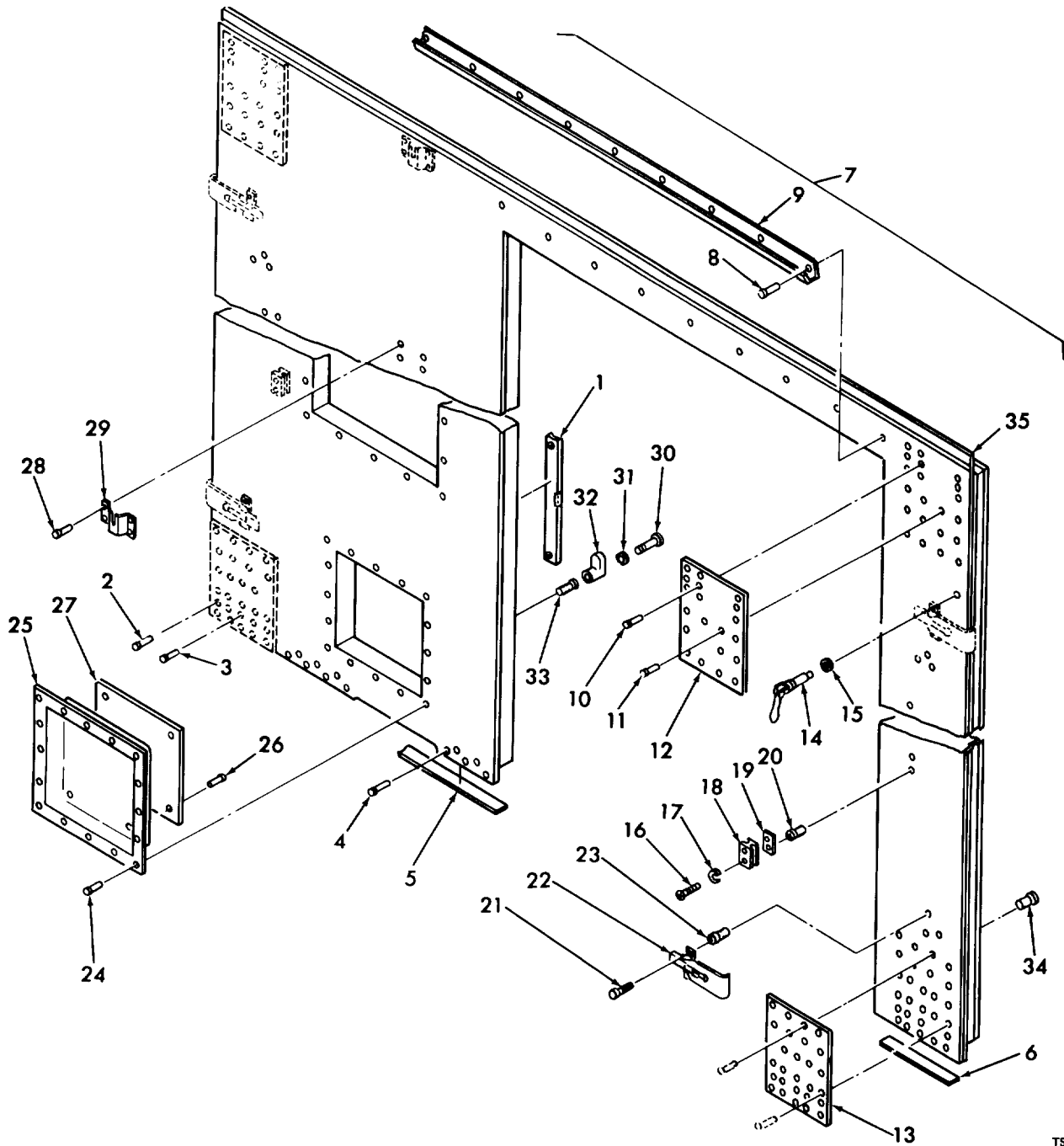

TS 023674

- |                                       |                                      |                                  |
|---------------------------------------|--------------------------------------|----------------------------------|
| 1. Level                              | 13. Plate (2)                        | 25. Pan                          |
| 2. Rivet (4)                          | 14. Receptacle and stud assembly (2) | 26. Rivet (4)                    |
| 3. Fastener (16)                      | 15. Gasket (2)                       | 27. Spacer                       |
| 4. Fastener (12)                      | 16. Screw (4)                        | 28. Rivet (8)                    |
| 5. strip                              | 17. Washer (4)                       | 29. Bracket (2)                  |
| 6. Strip                              | 18. Plate (2)                        | 30. screw (2)                    |
| 7. Personnel end fixed panel assembly | 19. Spacer (2)                       | 31. Washer (2)                   |
| 8. Rivet (9)                          | 20. Insert (4)                       | 32. Mount (2)                    |
| 9. Cap                                | 21. screw (12)                       | 33. Nut (2)                      |
| 10. Rivet (51)                        | 22. Latch (4)                        | 34. Nut (4)                      |
| 11. Rivet (25)                        | 23. Insert (12)                      | 35. Personnel end panel assembly |
| 12. Plate (2)                         | 24. Rivet (16)                       |                                  |

Figure 3-16. Personnel end panel assembly

(2) Removal and replacement of personnel end panel level mount (fig. 3-16). To remove and replace level mount (32), proceed as follows:

(a) Remove mason's level from level mount (32).

(b) Remove screw (30) and washer (31) to detach level mount (32).

(c) Replace level mount by securing to personnel end panel with screw (30) and washer (31).

(d) Replace level in level mounts.

(3) Removal and replacement of personnel end panel latch (fig. 3-16). To remove and replace latch (22), proceed as follows:

(a) Release latch (22) from associated strike.

(b) Remove two screws (21) to detach latch (22).

(c) Replace latch by securing to personnel end panel with two screws (21).

(4) Removal and replacement of personnel end and cargo end retainers (fig. 3-17). To remove and replace retainers (19 and 20) proceed as follows:

(a) Remove safety cable from around retainers (19 and 20).

(b) Remove screw (17) and washer (18) to detach both retainers (19 and 20).

(c) Replace retainers (19 and 20) by securing to personnel end panel with screw (17) and washer (18).

(d) Reposition safety cable around retainers for storage.

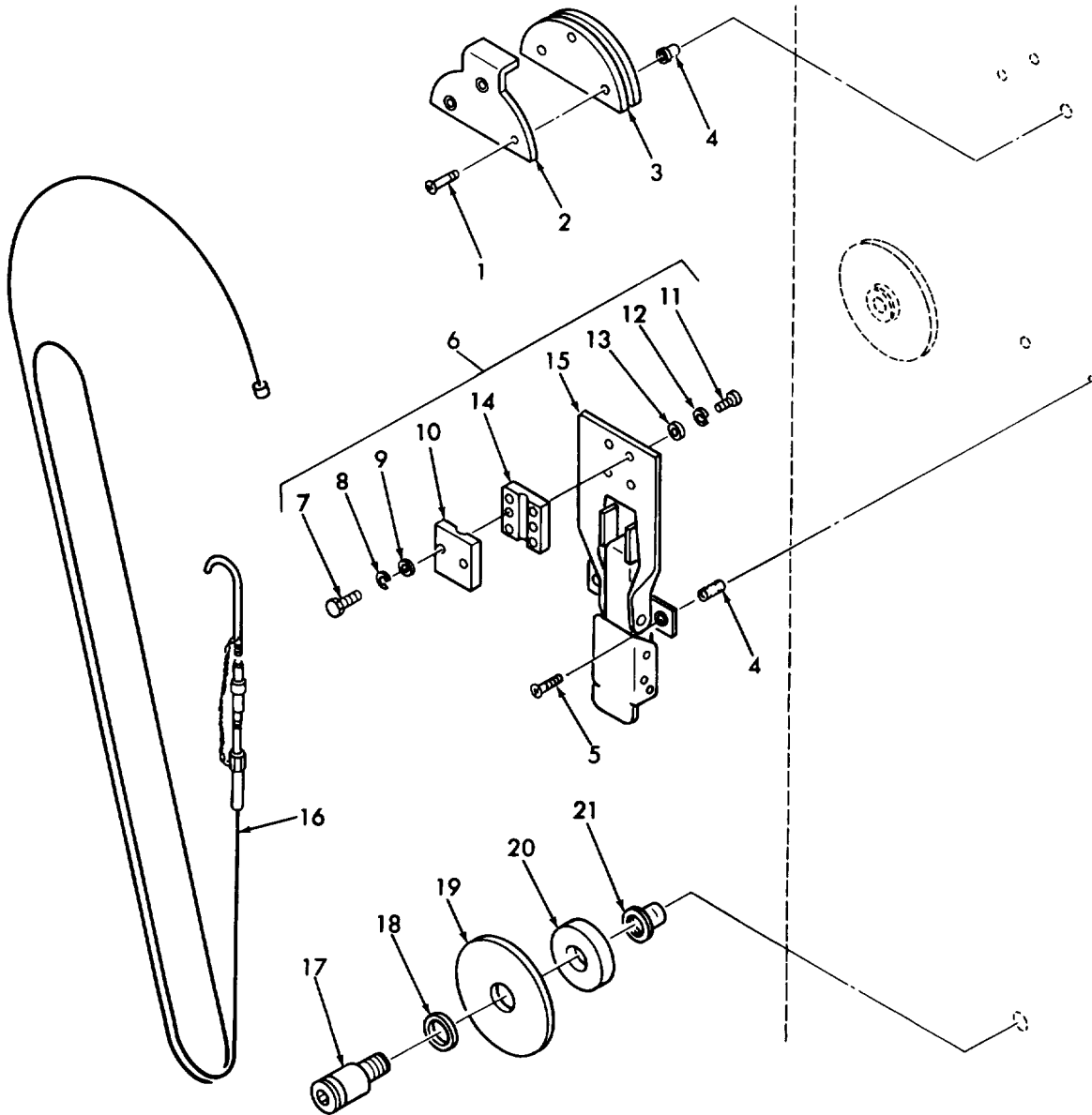

TS 023675

- |                                |                           |
|--------------------------------|---------------------------|
| 1. Screw (3)                   | 12. Washer (4)            |
| 2. Clip                        | 13. Washer (4)            |
| 3. Capstan                     | 14. clamp                 |
| 4. Insert (7)                  | 15. Latch                 |
| 5. Screw (4)                   | 16. Safety cable assembly |
| 6. Safety cable latch assembly | 17. screw (2)             |
| 7. Screw (2)                   | 18. Washer (2)            |
| 8. Washer (2)                  | 19. Retainer (2)          |
| 9. Washer (2)                  | 20. Retainer (2)          |
| 10. clamp                      | 21. Insert (2)            |
| 11. Screw (4)                  |                           |

Figure 3-17. Safety cable, latch assembly, and related parts

(5) Removal and replacement of mobilizer fitting assembly (fig. 3-18). To remove and replace mobilizer fitting assembly (3) on personnel or cargo end panel, proceed as follows:

(a) Remove six screws (1) and washers (2) to detach mobilizer fitting assembly (3).

(b) Replace mobilizer fitting assembly (3) by securing to end panel with six screws (1) and washers (2).

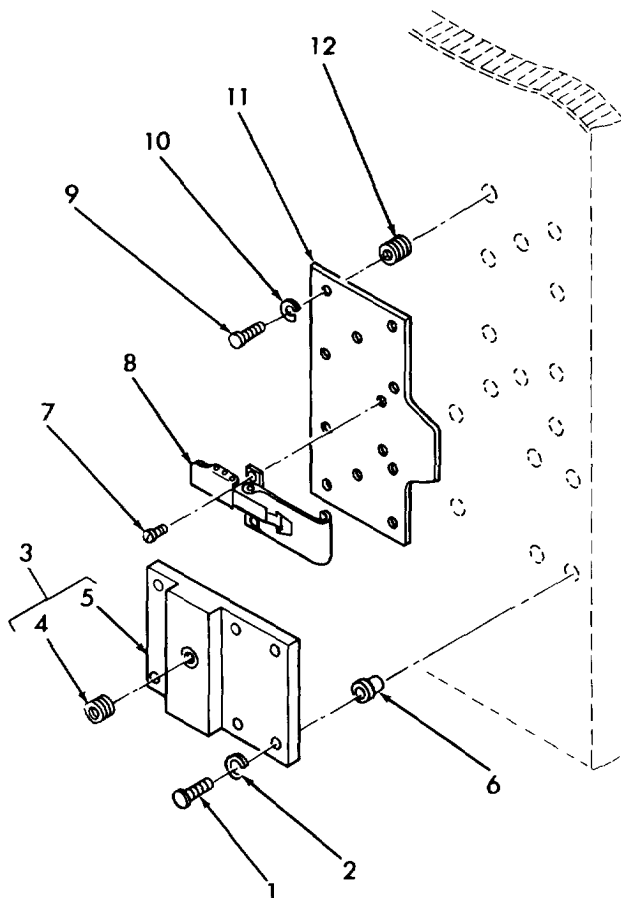

TS 023676

- |                     |                 |
|---------------------|-----------------|
| 1. Screw (6)        | 7. screw (4)    |
| 2. Washer (6)       | 8. Latch        |
| 3. Fitting assembly | 9. screw (10)   |
| 4. Insert           | 10. Washer (10) |
| 5. Fitting          | 11. Plate       |
| 6. Nut (6)          | 12. Insert (10) |

Figure 3-18. Mobilizer fitting and shear plate

(6) Removal and replacement of latch (fig. 3-18). To remove and replace latch (8) on personnel or cargo end panel, proceed as follows:

- (a) Release latch (8) from strike.
- (b) Remove two screws (7) to detach latch (8).
- (c) Replace latch (8) by securing to shear plate (11) on end panel with two screws (7).

(7) Removal and replacement of shear plate (fig. 3-18). To remove and replace shear plate (11) on personnel or cargo end panel, proceed as follows:

- (a) Remove 10 screws (9) and washers (10) to detach shear plate (11).

(b) Replace shear plate by securing to end panel with 10 screws (9) and washers (10).

(8) Removal and replacement of strike (fig. 3-19). To remove and replace strike (5) on personnel or cargo end panel, proceed as follows:

- (a) Release associated latch from strike (5).
- (b) Remove three screws (3) and washers (4) to detach strike.

(c) Replace strike (5) by securing to end panel with three screws (3) and washers (4).

- (d) Re-engage associated latch and strike (5).

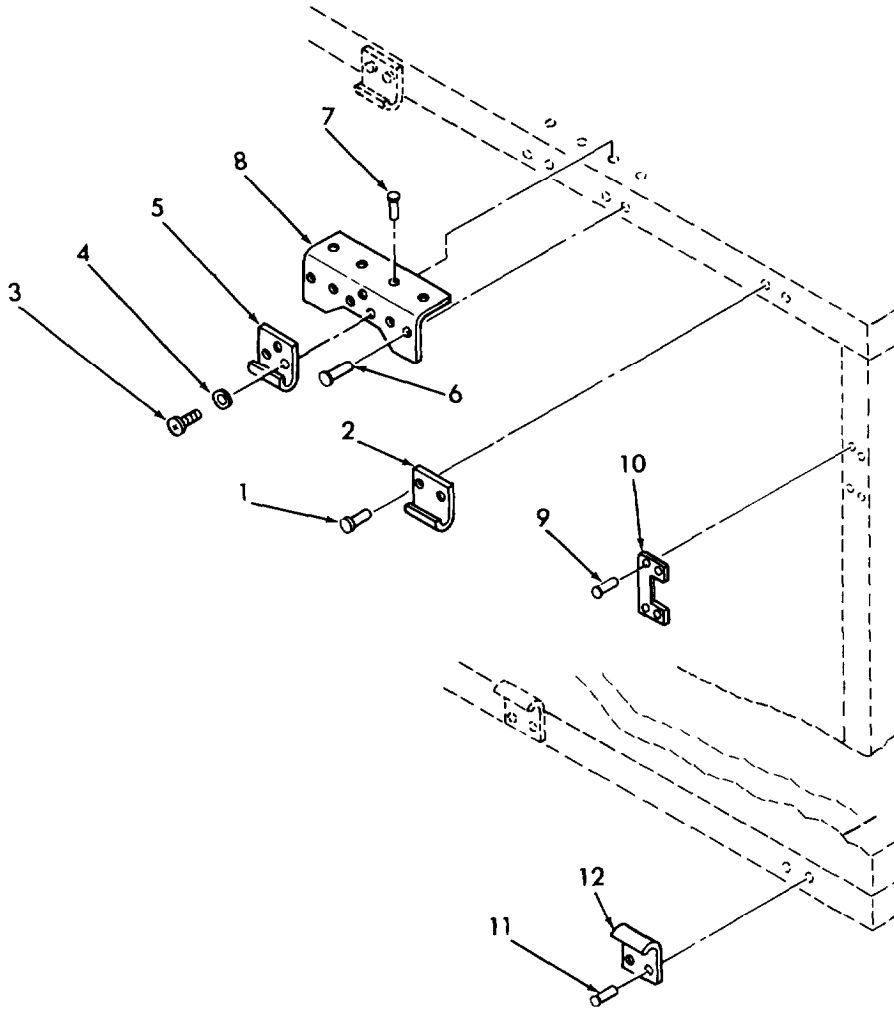

TS 023677

- |                 |                 |
|-----------------|-----------------|
| 1. Fastener (4) | 7. Fastener (4) |
| 2. Strike (2)   | 8. Shear (4)    |
| 3. Screw (3)    | 9. Rivet (4)    |
| 4. Washer (3)   | 10. Strike      |
| 5. Strike       | 11. Rivet (4)   |
| 6. Fastener (4) | 12. Strike (2)  |

Figure 3-19. Strikes and related parts

(9) Removal and replacement of personnel door handles and lock rods (fig. 3-20). To remove and replace door handles (2 and 7), lock rods (21) and associated hardware, proceed as follows:

(a) Remove groove pin (1) from handle (2) and remove handle and washer (3).

(b) Disengage two lock rods (21) from eccentrics on center case assembly (25) and remove lock rods.

(c) Remove four bolts (22) and washers (23) to detach center case assembly (25) and spacer (26). Also remove four rubber washers (27) and tube (28).

(d) Detach handle (7) by removing three screws (4), lock washers (5), and flat washers (6).

(e) Remove four screws (14), lock washers

(15), and flat washers (16) to detach case (17), to shim (18), and spacer (19).

**NOTE**

Replace the entire assembly in accordance with the following steps.

(f) Replace case (17) with shim (18) and spacer (19) in proper position and secure with four screws (14, lock washers (15), and flat washers (16).

(g) Attach bracket (7) to door using three screws (4), lock washers (5), and flat washers (6).

(h) Position tube (28) in hole in door and insert square shaft of handler (2) through handle bracket and tube (28).

(i) Slide four rubber washers (17) onto handle shaft.

(j) Attach spacer (26) and center case assembly (25) to door using four bolts (22) and washers (23).

(k) Slide lock rods (21) into case (17) and engage other ends with eccentrics on center case assembly (25).

(l) Position washer (3) and handle (2) on shaft of handle (7), align hole in handle (2) with hole in shaft and insert pin (1).

(m) Check that operation of door handles is free from binding.

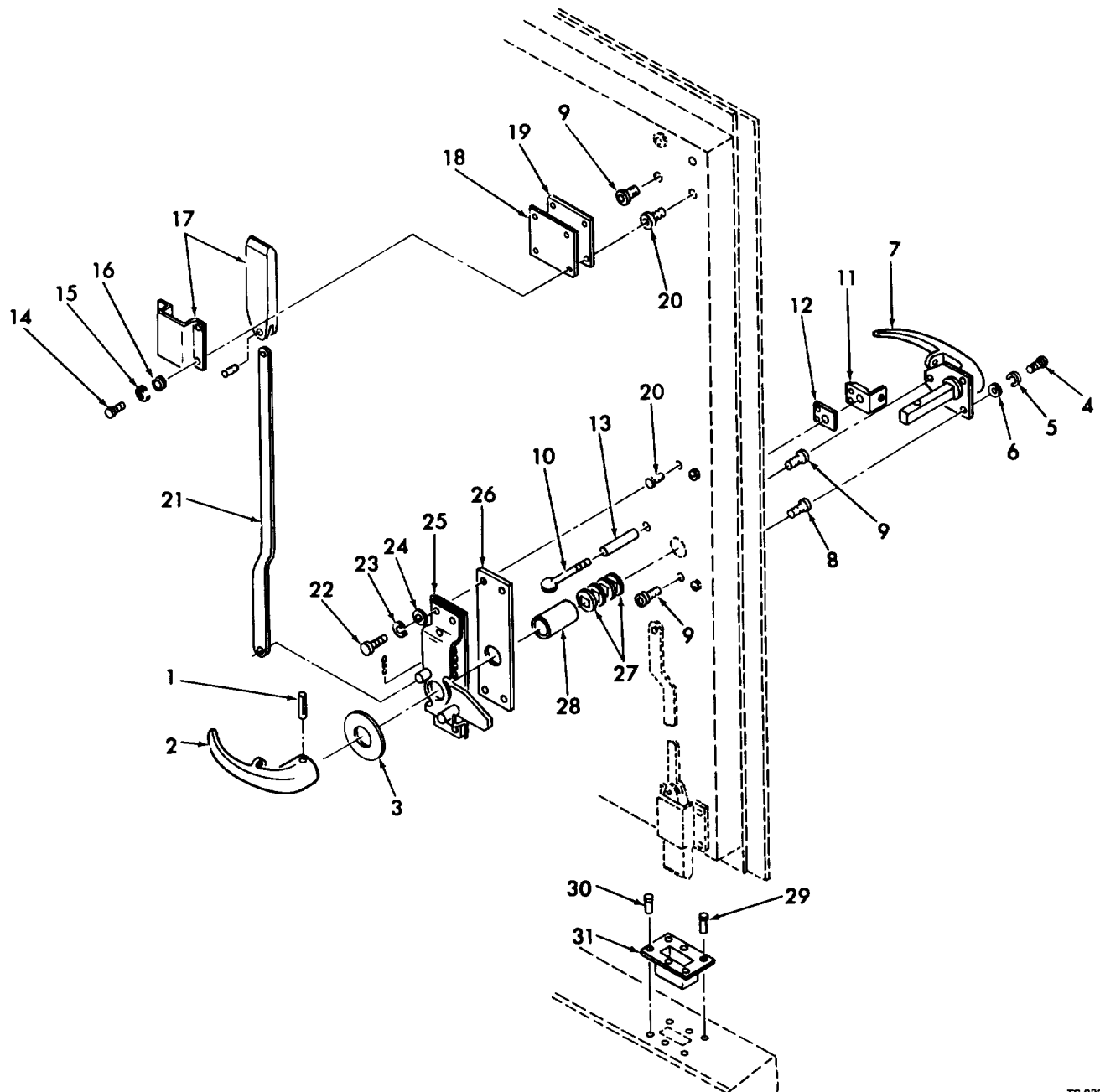

- |               |                |                |                          |
|---------------|----------------|----------------|--------------------------|
| 1. Pin        | 9. Insert (5)  | 17. Bolt (2)   | 25. Center case assembly |
| 2. Handle     | 10. Thumbscrew | 18. shim (2)   | 26. Spacer               |
| 3. Washer     | 11. Bracket    | 19. Spacer (2) | 27. Washer (4)           |
| 4. Bolt (3)   | 12. Seal       | 20. Nut (8)    | 28. Tube                 |
| 5. Washer (3) | 13. Sleeve     | 21. Rod (2)    | 29. Fastener (3)         |
| 6. Washer (3) | 14. Bolt (8)   | 22. Bolt (4)   | 30. Rivet (3)            |
| 7. Handle     | 15. Washer (8) | 23. Washer (4) | 31. Box                  |
| 8. Nut (2)    | 16. Washer (8) | 24. Washer (4) |                          |

Figure 3-20. Personnel and right cargo doors handle and lock

TS 023678

(10) Removal and replacement of personnel door-mounted jack support hardware (fig. 3-21). To remove and replace door-mounted jack support hardware, proceed as follows:

- (a) Remove five screws (20) and washers (21) to detach each jack support angle (22).
- (b) Remove two screws (24) and washers (25) to detach end jack support plate (26).

(25) to detach end jack support plate (26).

(c) Replace each jack support plate (26) by securing to door with two screws (24) and washers (25).

(d) Replace each jack support angle (37) by securing to door with four screws (34) and washers (35).

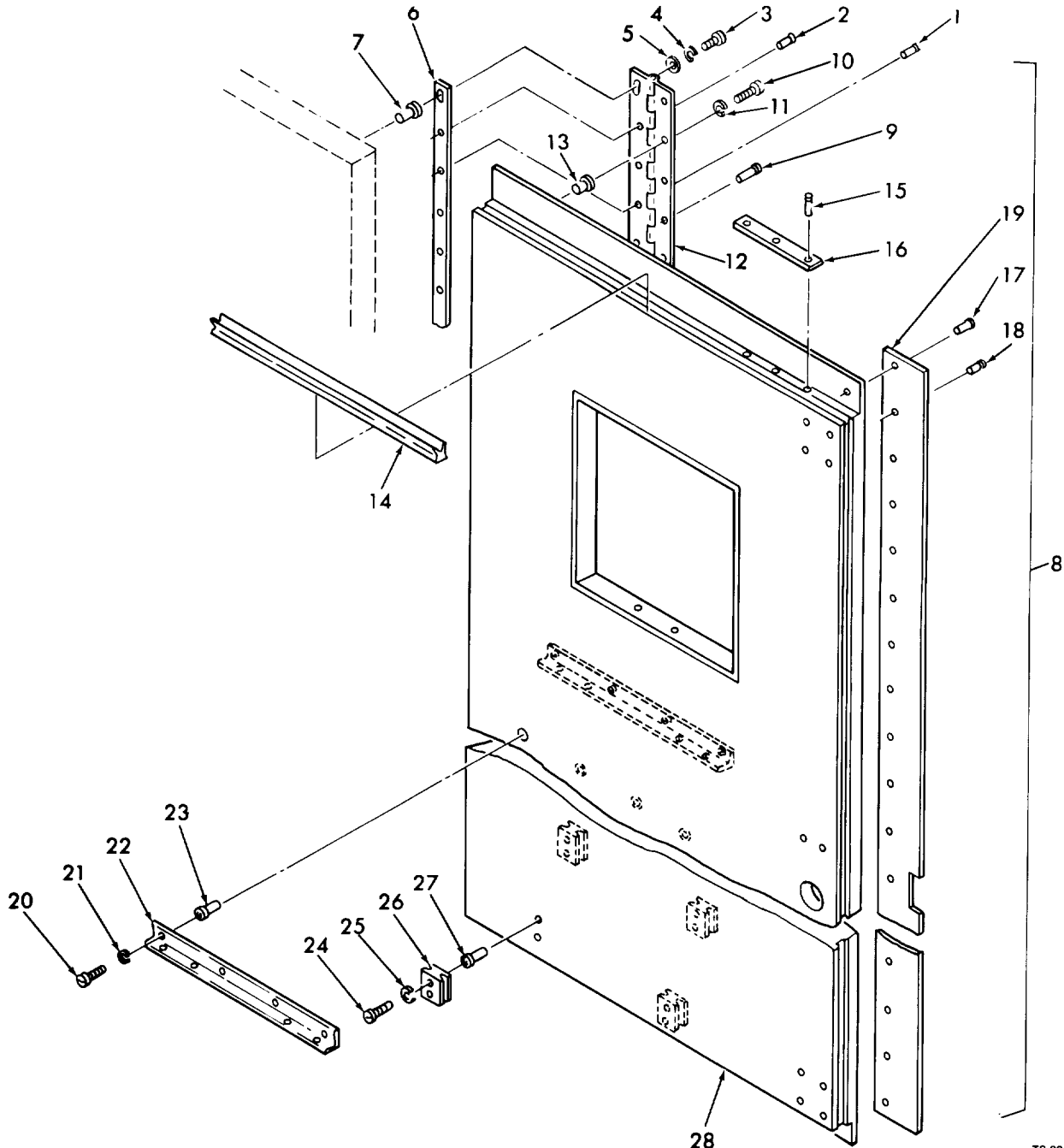

TS 023679

- |                 |                  |                |                                   |
|-----------------|------------------|----------------|-----------------------------------|
| 1. Rivet (22)   | 8. Door assembly | 15. Rivet (6)  | 22. Angle (2)                     |
| 2. Fastener (5) | 9. Rivet (25)    | 16. Block (2)  | 23. Insert (8)                    |
| 3. Screw (2)    | 10. Screw (2)    | 17. Rivet (2)  | 24. Screw (8)                     |
| 4. Washer (2)   | 11. Washer (2)   | 18. Rivet (20) | 25. Washer (8)                    |
| 5. Washer (2)   | 12. Hinge        | 19. Strip      | 26. Plate (4)                     |
| 6. Spacer       | 13. Insert (2)   | 20. Screw (8)  | 27. Insert (8)                    |
| 7. Insert (2)   | 14. Seal         | 21. Washer (8) | 28. Personnel door panel assembly |

Figure 9-21. Personnel and right cargo doors assembly



(11) Removal and replacement of door vent air filter (fig. 3-22). To remove and replace personnel cargo door vent air filter, proceed as follows:

(a) Loosen screws (11) in each of six lugs (13) around vent so that lugs can be swung away to release louver (17).

(b) Remove louver (17) and air filter (2) from vent opening.

(c) Remove air filter (2) from filter retainer (1) and install new air filter (2) onto filter retainer (1).

(d) Position air filter (2) and louver (17) in vent opening and use six lugs (13) to secure them.

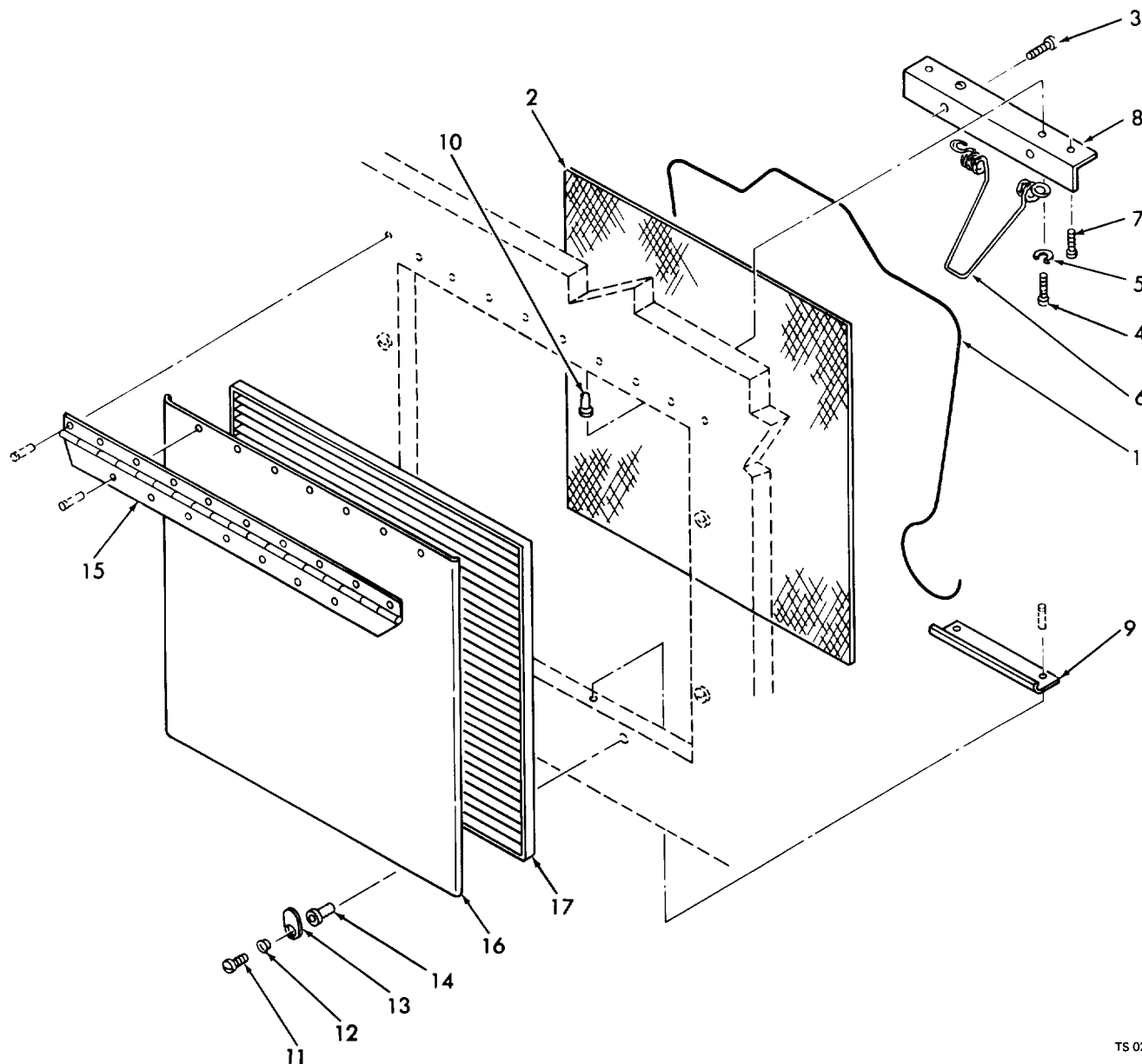

- |               |                |
|---------------|----------------|
| 1. Retainer   | 10. Nut (2)    |
| 2. Filter     | 11. Screw (6)  |
| 3. Screw      | 12. Cap (6)    |
| 4. Bolt (2)   | 13. Lug (3)    |
| 5. Washer (2) | 14. Insert (6) |
| 6. Spring     | 15. Hinge      |
| 7. Rivet (21) | 16. Door       |
| 8. Angle      | 17. Louver     |
| 9. Angle      |                |

Figure 3-22. Personnel and cargo doors vent installation

TS 023680

(12) Removal and replacement of jack support plate (fig. 3-23). To remove and replace jack support plate (26), proceed as follows:

- (a) Remove jack from jack support plate (26).
- (b) Remove two screws (24) and washers (25) to detach jack support plate.

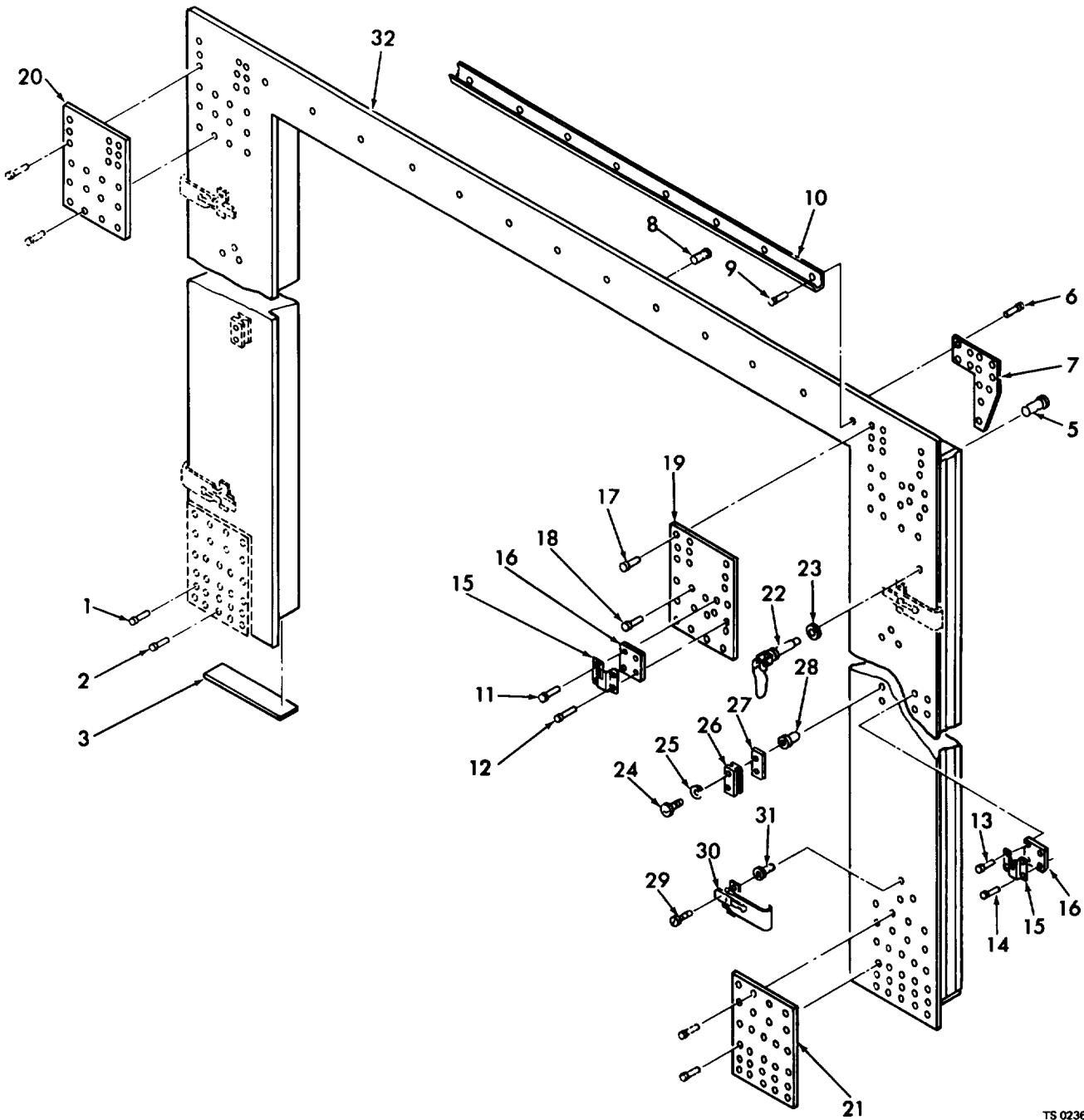

TS 023681

- |                           |                 |                                      |                    |
|---------------------------|-----------------|--------------------------------------|--------------------|
| 1. Rivet (4)              | 9. Rivet (13)   | 17. Rivet (55)                       | 25. Washer (4)     |
| 2. Fastener (16)          | 10. Cap         | 18. Rivet (20)                       | 26. Plate (2)      |
| 3. strip (2)              | 11. Rivet (2)   | 19. Plate                            | 27. Spacer (2)     |
| 4. Cargo endwall assembly | 12. Rivet (2)   | 20. Plate                            | 28. Insert (4)     |
| 5. Nut (4)                | 13. Rivet (2)   | 21. Plate (2)                        | 29. Screw (16)     |
| 6. Rivet (26)             | 14. Rivet (2)   | 22. Receptacle and stud assembly (2) | 30. Latch (4)      |
| 7. Plate (2)              | 15. Bracket (2) | 23. Gasket (2)                       | 31. Insert (16)    |
| 8. Nut (6)                | 16. Spacer (2)  | 24. Screw (4)                        | 32. Panel assembly |

Figure 3-23. Cargo end panel assembly

(c) Replace jack support plate by securing to personnel end panel with two screws (24) and washers (25).

(d) Install jack in accordance with paragraph 3-3a(3).

(13) Removal and replacement of right cargo door handles and lock rods (fig. 3-20). To remove and replace door handles (2 and 7), lock rods (21) and associated hardware, proceed as follows:

(a) Remove spring pin (1) from handle (2) and remove handle and washer (3).

(b) Disengage two lock rods (21) from eccentrics on center case assembly (25) and remove lock rods.

(c) Remove four bolts (22) and washers (23) to detach center case assembly (25). Also remove four rubber washers (27) and tube (28).

(d) Detach handle (7) by removing three screws (4), lock washers (5) and flat washers (6).

(e) Remove lock bracket (11) and seal (12) by removing thumbscrew (10), and sleeve (13).

(f) Remove four screws (14), lock washers (15), and flat washers (16) to detach case (17), shim (18), and spacer (19).

**NOTE**

Replace the entire assembly in accordance with the following steps.

(g) Replace case (17) with shim (18) and spacer (19) in proper position and secure with four screws (14), lockwashers (15) and lock washers (16).

(h) Attach lock bracket (11) and seal (12) to door with thumbscrew (10) and sleeve (13).

(i) Position tube (28) in hole in door and insert square shaft of handle (2) through handle bracket and tube (28).

(j) Attach handle bracket (7) to door using three screws (4), lockwashers (5), and flat washers (6).

(k) Slide four rubber washers (27) onto handle shaft.

(l) Attach center case assembly (25) to door using four bolts (22) and washers (23).

(m) Slide lock rods (21) into case (17) and engage other ends with eccentrics on center case assembly (25).

(n) Position washer (3) and handle (2) on shaft of handle (7), align hole in handle (2) with hole in shaft and insert pin (1).

(o) Check that operation of door handles is free from binding.

(14) Removal and replacement of step assembly (fig. 3-24). To remove and replace step assembly (16) on left cargo door, proceed as follows:

(a) Remove two screws (14) and washers (15) to detach each step assembly (16).

(b) Replace each step assembly (16) by securing to left cargo door with two screws (14) and washers (15).

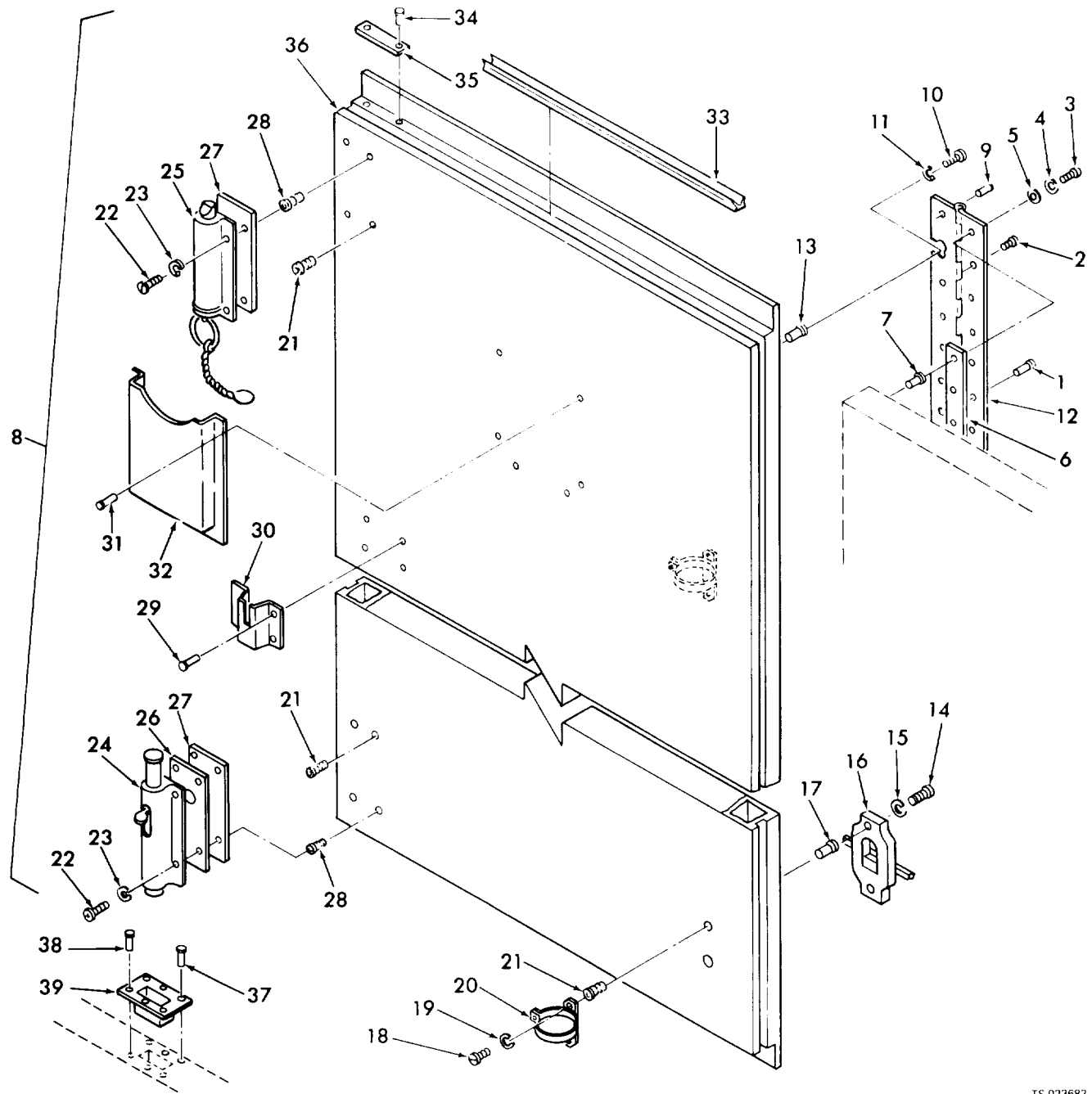

TS 023682

- |                  |                       |                 |                    |
|------------------|-----------------------|-----------------|--------------------|
| 1. Rivet (22)    | 11. Washer (2)        | 21. Insert (6)  | 31. Rivet (6)      |
| 2. Fastener (5)  | 12. Hinge             | 22. Screw (8)   | 32. Holder         |
| 3. Screw (2)     | 13. Nut (2)           | 23. Washer (8)  | 33. Seal           |
| 4. Washer (2)    | 14. Screw (8)         | 24. Foot bolt   | 34. Rivet (4)      |
| 5. Washer (2)    | 15. Washer (8)        | 25. Chain       | 35. Block (2)      |
| 6. Spacer        | 16. Step assembly (4) | 26. Spacer      | 36. Panel assembly |
| 7. Nut (2)       | 17. Insert (8)        | 27. Spacer (2)  | 37. Fastener (3)   |
| 8. Door assembly | 18. Screw (4)         | 28. Nut (6)     | 38. Rivet (3)      |
| 9. Rivet (25)    | 19. Washer (4)        | 29. Rivet (8)   | 39. Box            |
| 10. Screw (2)    | 20. Clamp (2)         | 30. Bracket (6) |                    |

Figure 3-24. Left cargo door assembly

(15) Removal and replacement of foot and chain bolts (fig. 3-24). To remove and replace foot bolt (24) and chain bolt (25) on left cargo door, proceed as follows:

(a) Remove four screws (22) and washers (23) to detach foot bolt (24) and spacers (26 and 27).

(b) Remove four screws (22 ) and washers (23) to detach chain bolt (25) and spacer (27).

(c) Replace foot bolt (24) and spacers (26 and 27) by securing to left cargo door with four screws (22) and washers (23).

(d) Replace chain bolt (25) and spacer (27) by securing to left cargo door with four screws (22) and washers (23).

### 3-22. Center Structure Roof and Floor Panels.

a. *General.* The center structure roof and floor panels are fixed structures of the expandable shelter, and are the center sections of the roof and floor of the deployed shelter. The following paragraphs contain inspection and repair in-

formation of the center structure roof and floor panels.

b. *Inspection.* Check that all seals are secure. Inspect surface for damage. Check roof drop pad. Check roof handle and plate.

c. *Repair.* Refer to shelter body repair instructions given in paragraph 3-16.

### 3-23. Leveling Jacks.

a. *General.* There are eight leveling jacks contained in the expandable shelter. The leveling jacks are provided with a ratchet wrench, and are used to support the deployed shelter and keep it level. The following paragraphs contain inspection and repair procedures.

b. *Inspection.* Check for mounting and general security of jacks. Lubricate jack screw in accordance with paragraph 3-12. Check that ratchet operates freely.

c. *Repair.* There are no complex repair procedures required for the leveling jack assemblies.

## Section VIII. MAINTENANCE OF ELECTRICAL SYSTEM

### 3-24. General.

The electrical system is a circuit-breaker controlled network of lights, switches, and outlets including power cables for two ventilation fans and two ECU's. Site power consisting of 120/208-volts, 3-phase, 60-Hz is received by a connector on the service entrance panel and is routed to a 100-ampere main circuit breaker (CB1) on the circuit breaker panel. As shown in figure 3-25, the primary power is then made available in the circuit breaker panel for single-phase distribution to several circuit breakers. However, the three-phase power is made available for operation of the ECU's. All of the circuit breakers (in the on position) provide overload protection to the circuits involved. Switches are also provided for all interior lighting and for the ventilation fans. The light switches are located on the side of the circuit breaker panel whereas the fan switches are in switch boxes positioned above the intended locations for the fans.

### 3-25. Circuit Breaker Panel.

a. *General.* The circuit breaker panel is located on the inside of the expandable shelter on the personnel end panel. The circuit breaker panel

contains 14 circuit breakers on its front panel and 4 switches on its side panel. These circuit breakers and switches provide overload protection and control the application of electrical power throughout the expandable shelter. The following paragraphs contain the inspection and testing information for the circuit breaker panel.

b. *Inspection.* Check circuit breakers and switches for security of attachment and proper mechanical operation. Check general condition of structure and door. Check condition of wires and connections.

#### **WARNING**

Site power, which is present in the circuit breaker panel, is lethal. Before any work is done inside the circuit breaker panel, make sure that the site power cable is disconnected by a qualified electrician.

c. *Testing.* The testing of the circuit breaker panel consists of setting all circuit breakers and switches to on position, and then check that electrical power is distributed throughout the expandable shelter as specified in table 2-1. If a malfunction occurs proceed to the appropriate troubleshooting procedure in table 3-4.

**FO1. (LOCATED IN THE BACK OF THE MANUAL).**

### 3-26. Wiring, Receptacles, and Outlets.

a. *General.* The wiring, receptacles, and outlets are located at the top of the inside walls and on the ceiling of the expandable shelter. Receptacles and outlets are also located on the power entrance panel on the outside of the shelter. The wiring, receptacles, and outlets are used to distribute and make available electrical power required for the operation of the expandable shelter. The following paragraphs contain the inspection, removal, and installation information for the wiring, receptacles, and outlets.

b. *Inspection.* Check condition of electrical connectors. Check for presence of dirt, rust, or corrosion. Check for condition of grounding stud. Check shelter floors, walls, and ceiling for general condition and security. Check electrical wiring, receptacles, and outlets for security of attachment and condition. Check ventilation fans for proper installation, general condition, and operation. Check ceiling lights and receptacles for proper installation, general condition, and operation.

#### **WARNING**

The expandable shelter contains voltages that are dangerous if contacted. Before replacing electrical components, make certain electrical power is completely disconnected from the circuit involved.

c. *Removal.* The following procedure contains the instructions for removing the wiring, receptacles, and outlets of the expandable shelter:

(1) Turn all associated circuit breakers and switches on the circuit breaker panel to off position. Lock out the circuit breaker panel.

(2) Remove connections from wiring conduits and cable assemblies.

#### **NOTE**

If necessary tag all leads for reconnection.

(3) Remove screws (fig. 3-11, view D) and washers securing clamps and pipe straps which hold the wiring conduits and cable assemblies.

(4) Remove conduits and cable assemblies,

#### **WARNING**

Before removing power entrance receptacle J1, the external power cable must be removed by a qualified electrician.

(5) Remove connections from receptacles and outlets.

(6) Tag all leads for reconnection.

(7) Remove fasteners (fig. 3-11, view E) which secure the receptacles and outlets to the expandable shelter.

(8) Remove receptacles and outlets.

*d Installation.* The following procedure contains the instructions for installing the wiring, receptacles, and outlets of the expandable shelter:

(1) Install new wiring in conduits and cable assemblies, and secure to expandable shelter using pipe straps (fig. 3-11), clamps, washers, and screws.

(2) Make proper connections to conduits and cables.

(3) Install new receptacles and outlets, and secure to expandable shelter using fasteners (fig. 3-11).

(4) Make proper connections to receptacles and outlets.

(5) Turn all circuit breakers and switches on circuit breaker panel to on position.

(6) Remove all tags from leads.

### 3-27. Light Assemblies.

a. *General.* The interior light assemblies are located on the ceiling of the expandable shelter and above the circuit breaker panel. The exterior light assembly can be located above and to the left of the personnel entrance door or next to the cargo doors. The light assemblies provide all the light required by the expandable shelter. The following paragraphs contain the inspection, repair, removal, and installation information for the light assemblies.

b. *Inspection.* Check operation of exterior light. Check electrical wiring for proper attachment and condition. Check ceiling lights for proper installation, general condition, and operation.

c. *Repair.* There are no special repair procedures required for the light assemblies except for the exterior light assembly. This assembly can be repaired by removal and replacement of defective parts. The following is a step-by-step procedure for disassembly and reassembly of the exterior light assembly and should be used to the extent required to remove and replace a part.

(1) Detach lampholder (2, fig. 3-26) from post (19) by removing screw (13).

(2) Remove screw (4), washer (5), and nut (6) to detach cable (12) and loop clamp (7) from post (20).

(3) Remove cable (12) from lampholder (2) by cutting wires at splice. Remove old splices (8).

(4) Re-splice new cable (12) to wires extending out of lamp-holder (2).

(5) Attach cable (12) to post (20) using clamp loop (7), screw (4), washer (5), and nut (6).

(6) Attach lampholder (2) to post (20) using screw (13).

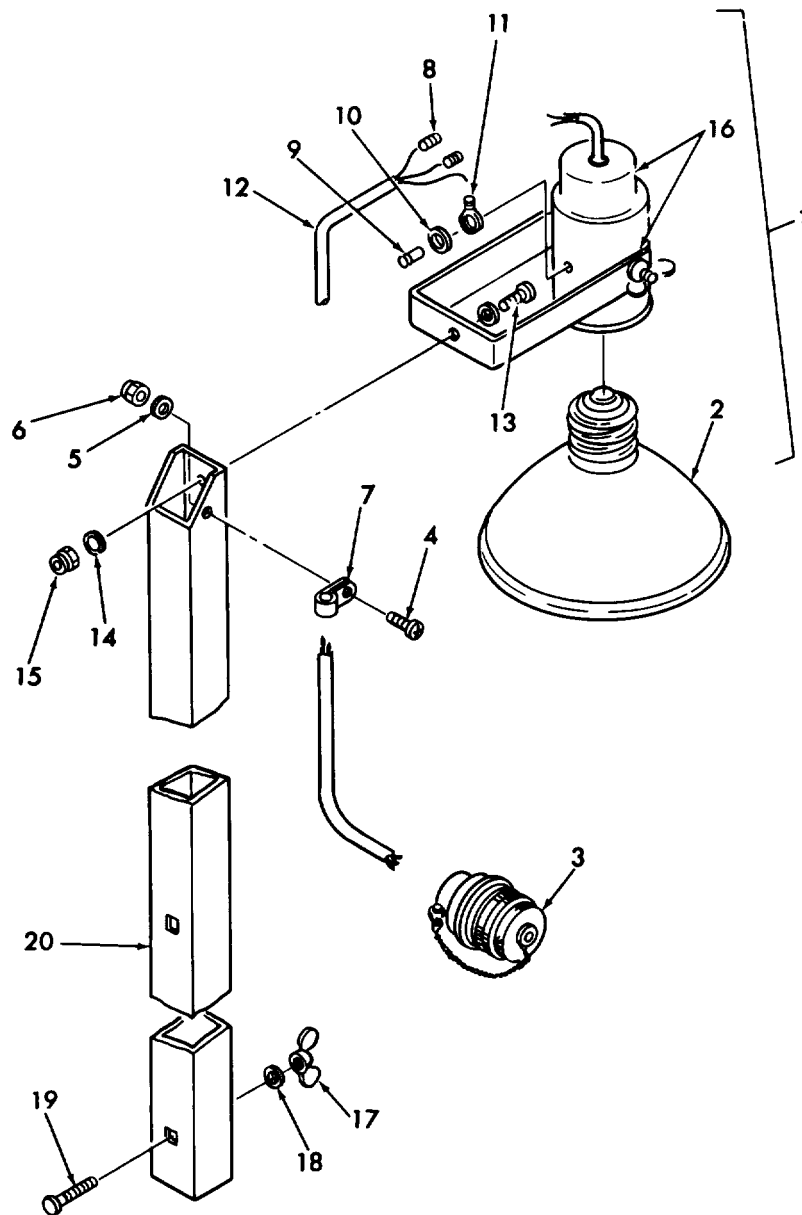

TS 023684

- |                            |                         |
|----------------------------|-------------------------|
| 1. Exterior light assembly | 11. Terminal            |
| 2. Flood lamp              | 12. Cable (25)          |
| 3. Connector               | 13. Screw               |
| 4. screw                   | 14. Washer (2)          |
| 5. Washer                  | 15. Nut                 |
| 6. Nut                     | 16. Lampholder assembly |
| 7. clamp                   | 17. Nut (2)             |
| 8. Splice (2)              | 18. Washer (2)          |
| 9. Rivet                   | 19. Bolt (2)            |
| 10. Washer                 | 20. Poet                |

Figure 3-26. Exterior light assembly

d. Removal. The following procedures contain the instructions for removing the interior light assemblies and the exterior light assembly.

(1) Interior ceiling lights.

(a) Turn all associated circuit breakers and switches on circuit breaker panel to off position.

(b) Disconnect ceiling light power cord (fig. 3-11, view D).

(c) Remove lamps from ceiling light.

(d) Loosen captive screw on ceiling light.

(e) Slide ceiling light assembly left or right

to disengage support plate from captive fasteners in ceiling.

(f) Remove ceiling light.

(2) *Exterior light assembly.*

(a) Turn circuit breaker CB5 or CB7 (whichever is applicable) on circuit breaker panel to off position.

(b) Disconnect exterior light cable (fig. 3-11; view C) from utility outlet on power entrance panel.

(c) Loosen two wing nuts securing exterior light post to exterior light mounting bracket on personnel end panel (or cargo end panel).

(d) Remove exterior light.

e. *Installation.* The following procedures contain the instructions for installing the interior ceiling light and the exterior light assemblies.

(1) *Interior ceiling lights.*

(a) Install new ceiling lights by engaging support plate (figure 3-11, view D) with captive fasteners in ceiling.

(b) Tighten captive screw on ceiling light.

(c) Install lamps in ceiling light.

(d) Connect ceiling light power cord.

(e) Turn all circuit breakers and switches on circuit breaker panel to on position.

(2) *Exterior light assembly.*

(a) Install new light assembly and secure to personnel end panel (or to cargo end panel) using the two wing nuts (fig. 3-11, view E).

(b) Reconnect exterior light power cord to utility outlet on power entrance panel.

(c) Turn circuit breaker CB5 or CB7 (whichever is applicable) on circuit breaker panel to on position.

### **3-28. Ventilation Fans.**

a. *General.* The expandable shelter can accommodate two ventilation fans in two locations on the two foldout end walls. The fans are reversible and are used for exhaust and ventilation. The following paragraphs contain the inspection, repair, removal, and installation procedures.

#### **NOTE**

When ECU's are installed and used, the ventilation fans are not installed.

b. *Inspection.* Check ventilation fans for proper installation, general condition, and operation.

c. *Repair.* There are no complex repair procedures required for the ventilation fan.

d. *Removal.* The following procedure contains the instructions for removing the ventilation fan:

(1) Turn appropriate fan switch S5 and S6 (depending upon installation location) to OFF position.

(2) Turn circuit breaker CB14 on circuit breaker panel to off position.

(3) Disconnect power cable from connector (21, fig. 3-27) on fan.



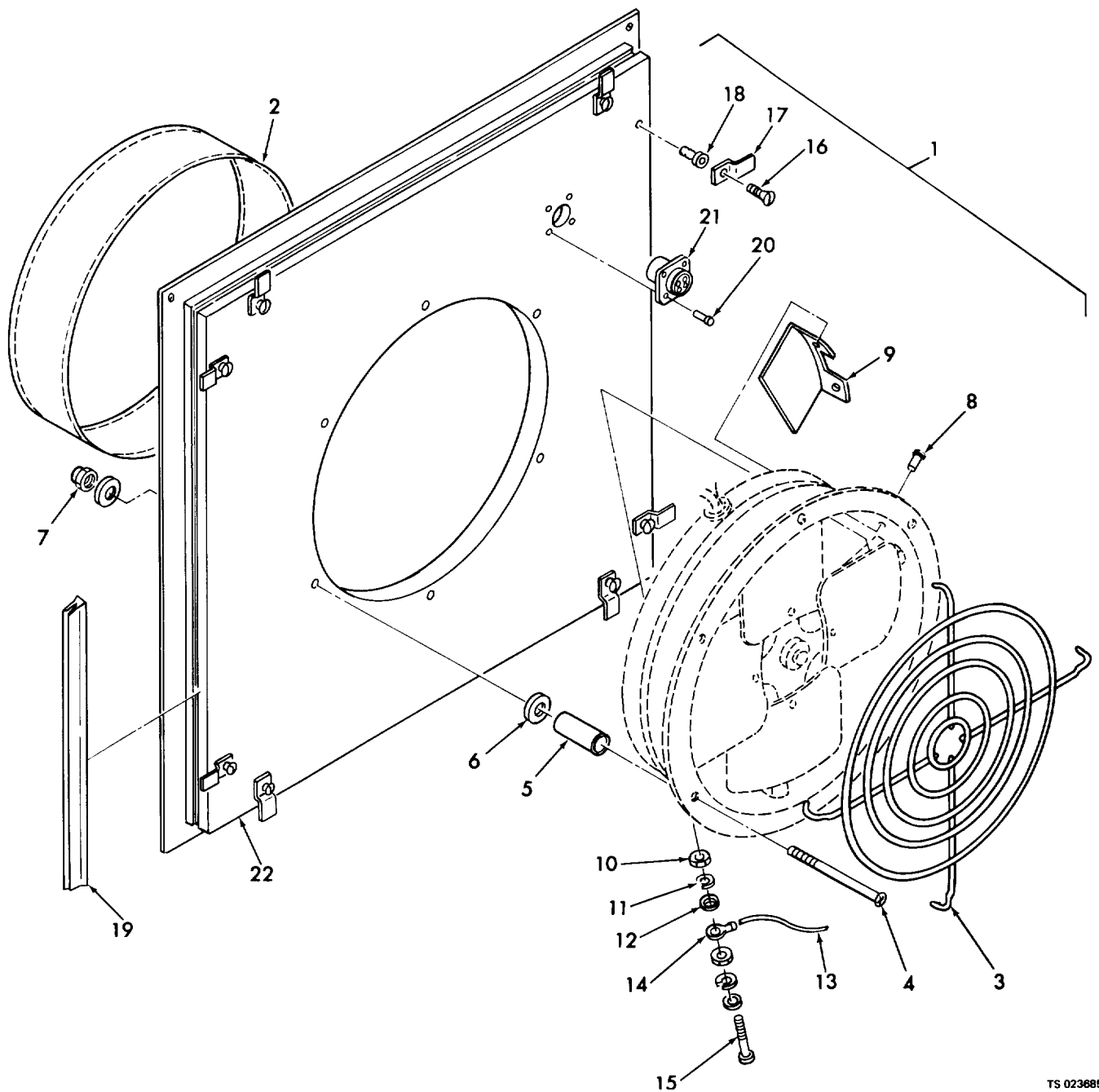

TS 023685

- |                 |                      |
|-----------------|----------------------|
| 1. Fan assembly | 12. Washer (2)       |
| 2. Cover        | 13. Wire (12)        |
| 3. Cover        | 14. Terminal         |
| 4. Screw (6)    | 15. Screw            |
| 5. Spacer (6)   | 16. Thumbscrew (8)   |
| 6. Washer (6)   | 17. Dog brackets (8) |
| 7. Nut (6)      | 18. Nut (8)          |
| 8. Rivet (2)    | 19. Seal             |
| 9. Plate        | 20. Rivet (4)        |
| 10. Nut (2)     | 21. Connector        |
| 11. Washer (2)  | 22. Panel assembly   |

Figure 3-27. Ventilation fan assembly

(4) Loosen eight thumbscrews (16) securing dog brackets (17), to fan panel assembly (22).

(5) Position the eight dog brackets to release the fan panel assembly.

(6) Carefully remove fan panel assembly from foldout end wall.

(7) Remove nut (10) and washers (11 and 12) securing terminal lug (14) to screw (15) on fan assembly.

(8) Remove six screws (4), spacers (5), washers (6), and nuts (7) securing fan assembly to fan panel assembly.

(9) Remove fan assembly.

e. Installation. The following procedure contains the instruction for installing the ventilation fan:

(1) Install new fan assembly (1, fig. 27) into fan panel assembly (22) and secure using six screws (4), spacers (5), washers (6), and nuts (7).

(2) Secure terminal lug (14) to screw (15) on

fan assembly using washers (11 and 12) and nut (10).

(3) Carefully install fan panel assembly into foldout end wall.

(4) Position dog brackets (17) to hold the fan panel assembly to the foldout end wall. Secure each dog bracket using thumbscrew (16).

(5) Connect fan power cable.

(6) Turn circuit breaker CB14 on circuit breaker box to on position.

(7) To operate fan set appropriate three position fan switch S5 or S6 to desired position.

### **3-29. ECU's.**

The ECU's are not supplied as part of the shelter. However, for installation and removal instructions, refer to paragraph 3-3 *f* and paragraph 3-4, steps (1) through (8).

CHAPTER 4

DIRECT AND GENERAL SUPPORT MAINTENANCE INSTRUCTIONS

Section I. REPAIR PARTS, SPECIAL TOOLS, AND EQUIPMENT

**4-1. Direct and General Support Maintenance Tools and Equipment.**

The tools and equipment issued for direct and general support maintenance of the expandable shelter are listed in Section III of Appendix D (Maintenance Allocation Chart) of this manual.

**4-2. Direct and General Support Maintenance Special Tools and Equipment.**

Appendix D, Section III contains the authorized

special tools required for direct and general support maintenance.

**4-3. Direct and General Support Maintenance Repair Parts.**

The repair parts and equipment required for direct and general support maintenance of the expandable shelter are contained in TM 10-5410-224-24P, Repair Parts and Special Tools List.

Section II. TROUBLESHOOTING

**4-4. General.**

This section contains direct and general support maintenance troubleshooting information for locating and correcting most of the operating troubles which may develop in the expandable shelter.

**WARNING**

**The expandable shelter contains voltages that are dangerous if contacted. Take appropriate precautions when troubleshooting. Before performing continuity checks or replacing electrical components, make certain electrical power is completely disconnected from the circuit involved.**

**4-5. Troubleshooting Table.**

a. Each malfunction for an individual component, unit, or system is listed in troubleshooting table 4-1.

The malfunction is followed by a list of test or inspections which help to determine probable causes and corrective actions to take. The tests or inspections and corrective actions are to be performed in the order listed in the table.

b. All malfunctions that occur, tests or inspections, and corrective actions cannot be listed in table 4-1. If a malfunction is not listed or is not corrected by listed corrective actions, the appropriate supervisory personnel should be notified.

c. Unless otherwise noted, when troubleshooting the operation of the expandable shelter, the switches, controls, and circuit breakers must be placed in proper operating positions and power must be properly connected.

**NOTE**

All circuit breakers and switches called out in troubleshooting table 4-1 are located on circuit breaker panel.

*Table 4-1. Direct and General Support Maintenance Troubleshooting*

**MALFUNCTION**

**TEST OR INSPECTION**

**CORRECTIVE ACTION**

**CIRCUIT BREAKER PANEL**

**NO POWER IS DISTRIBUTED WITHIN THE EXPANDABLE SHELTER.**

*Step 1.* Check main circuit breaker CB 1.

Repair or replace circuit breaker CBI (para. 4-15).

**RIGHT CEILING LIGHTS FAIL TO COME ON.**

*Step 2.* Check circuit breaker CB4 and switch S1.

Repair or replace defective item (para. 4-15).

MALFUNCTION	TEST OR INSPECTION	CORRECTIVE ACTION
<b>CENTER STRUCTURE CEILING LIGHTS FAIL TO COME ON.</b>	Step 3. Check circuit breaker CB6 and switch S2.	Repair or replace defective item (para. 4-15).
<b>LEFT CEILING LIGHTS FAIL TO COME ON.</b>	Step 4. Check circuit breaker CB8 and switch S3.	Repair or replace defective item (para. 4-15).
<b>EMERGENCY (INTERIOR) LIGHT FAILS TO COME ON.</b>	Step 5. Check circuit breaker CB9 and switch S4.	Repair or replace defective item (para. 4-15).
<b>NO POWER AT ONE OF THE ECU RECEPTACLES.</b>	Step 6. Check associated circuit breaker CB2 or CB3.	Repair or replace defective circuit breaker (para. 4-15).
<b>NO POWER AT ONE OF THE GROUPS OF UTILITY OUTLETS.</b>	Step 7. Check associated circuit breaker CB10, CB11, CB12, or CB13.	Repair or replace defective circuit breaker (Para. 4-15).
<b>NO POWER AT ONE OF THE EXTERIOR OUTLETS (EXTERIOR LIGHT).</b>	Step 8. Check associated circuit breaker CB5 or CB7.	Repair or replace defective circuit breaker (para. 4-15).
<b>VENTILATION FAN FAILS TO OPERATE.</b>	Step 9. Check circuit breaker CB14 and appropriate switch S5 or S6.	Repair or replace defective item (para. 4-15).

**Section III. GENERAL RIVET AND INSERT REPAIR**

**4-6. General.**

This section provides maintenance personnel with general repair and replacement instructions applicable to rivets and inserts used in the expandable shelter.

**4-7. Blind Type Rivet Replacement.**

a Removal. Rivets which are damaged or used for securing a replaceable part shall be removed as follows:

(1) Drill through the center of the rivet. Use a drill bit with the same diameter as the original rivet hole. The drill must be held perpendicular to the surface to prevent enlargement or damage to the existing hole. Drill through just deep enough to sever the rivet head from the shank.

(2) Remove any remaining rivet with a pin punch and remove any burrs from rivet hole.

b. Rivet Replacement. Select a rivet of the proper diameter and length and install as follows:

(1) Hold parts to be riveted tightly together with clecos, clamps or other satisfactory method.

(2) Insert proper rivet in hole and apply with hand meter by inserting stem head of rivet in bottom slot in appropriate nose piece.

**NOTE**

Wet all rivets with sealant MIL-S-8802 before installation.

(3) Hold riveter at right angle to work. Push riveter against work with just enough force to firmly seat rivet and to aid in avoiding sheet or other part separation.

(4) Pull rivet until stem breaks.

(5) Trim the broken stem flush with the rivet head.

(6) Firmly press on the installed rivet to assure tightness.

**4-8. Insert Replacement.**

a Removal. Insert which are damaged shall be removed as follows:

(1) Use a drill with the same size as the original potting hole, and drill out the insert.

(2) Remove loose particles from the hole using a compressed air blast of clean air.

b. Potting Compound Mixing and Application. The potting compound, BMS 200067 shall be mixed for use with BN532 Series inserts. Mix and apply as follows:

(1) Mix the potting compound according to the manufacturer's instructions.

(2) Immediately after mixing, fill the hole with potting compound. Make sure that the hole is completely filled and free of air pockets.

c. Installation of BN532 Series Inserts. Install the new insert as follows:

(1) Perform potting compound mixing and application procedure given in paragraph 4-8b.

- (2) Wipe insert with solvent.
- (3) Use header fastener (see Appendix D, Section 111) to install and secure insert in hole (see figure 4-1).

- (4) Wipe away excess potting compound. Do not allow potting compound to get into the insert.

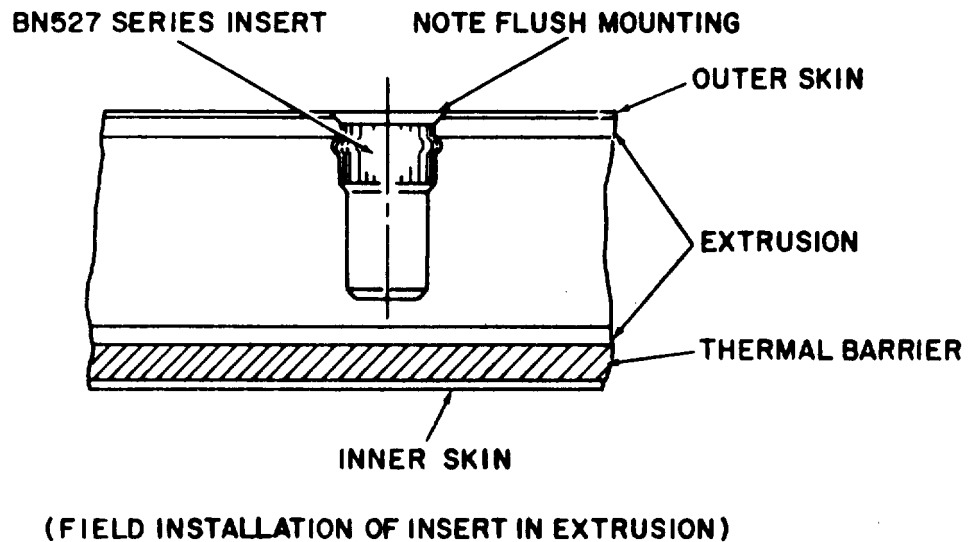
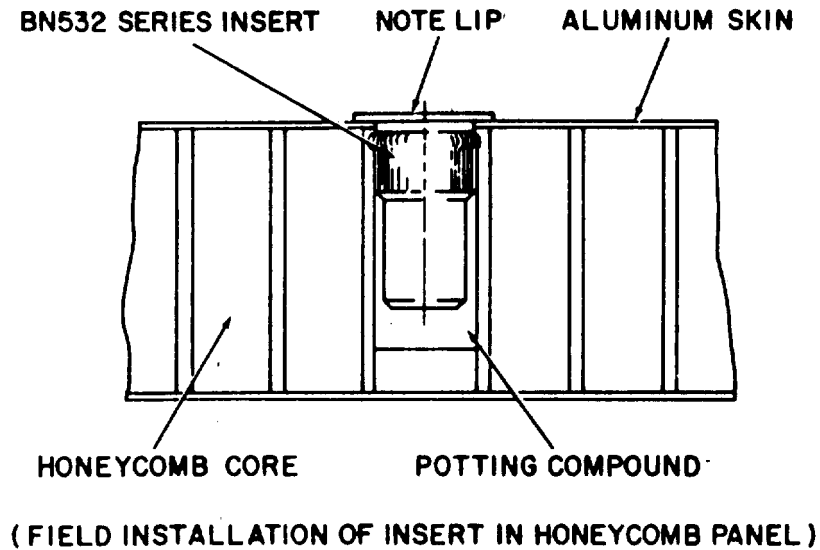

Figure 4-1. Field installation of inserts

d. *Installation of BN527 Series Inserts.* Install the new insert as follows:

- (1) Coat edges of insert with sealant, RTV 732.
- (2) Use header fastener (see Appendix D, Section III) to install and secure insert in hole (see figure 4-1).

**NOTE**

It is important that the edges of the insert be sealed with sealant, RTV 732.

**Section IV. REMOVAL AND INSTALLATION OF MAJOR COMPONENTS AND ASSEMBLIES**

**4-9. General.**

This section contains the removal and installation procedures for the shelter body and electrical system of the expandable shelter, as allocated by direct and general support maintenance.

**4-10. Preliminary Procedure.**

**WARNING**

**The expandable shelter contains voltages that are dangerous if contacted. Before removing or installing electrical cables or components, make certain electrical power is completely disconnected from the circuit involved. Four men are required to perform the removal and installation procedures for the shelter body.**

**NOTE**

Do not remove any panel for the purpose of repair unless absolutely necessary. Most panel repair can be accomplished while panels are installed.

- a. Turn all circuit breakers on circuit breaker panel to off position.

**NOTE**

Do not attempt to remove any panel or major part of the center structure. These procedures only apply to the foldout sections.

- b. Disconnect and remove tie down cables from section of shelter where component is being removed.

- c. Disconnect and if necessary remove all electrical cables and components that may interfere with the removal of the assembly. Refer to paragraph 3-26b. for removal procedures.

**WARNING**

**Removal of power cable from receptacle J1 on power entrance panel must be accomplished by a qualified electrician.**

**4-11. Swingout Walls.**

- a. Removal To remove the swingout walls from the expandable shelter, perform the following procedure:

- (1) Perform preliminary procedure of paragraph 4-10.

- (2) Unpin roof support struts from stowed position on one side of expandable shelter. Place struts in position to support foldout roof panel on section where swingout wall is being removed (figure 3-9).

- (3) Inside shelter, release two latches (4, figure 4-2) securing each swingout wall to the foldout roof panel. Also, release six latches (16, figure 4-3) securing foldout end wall to foldout roof panel.

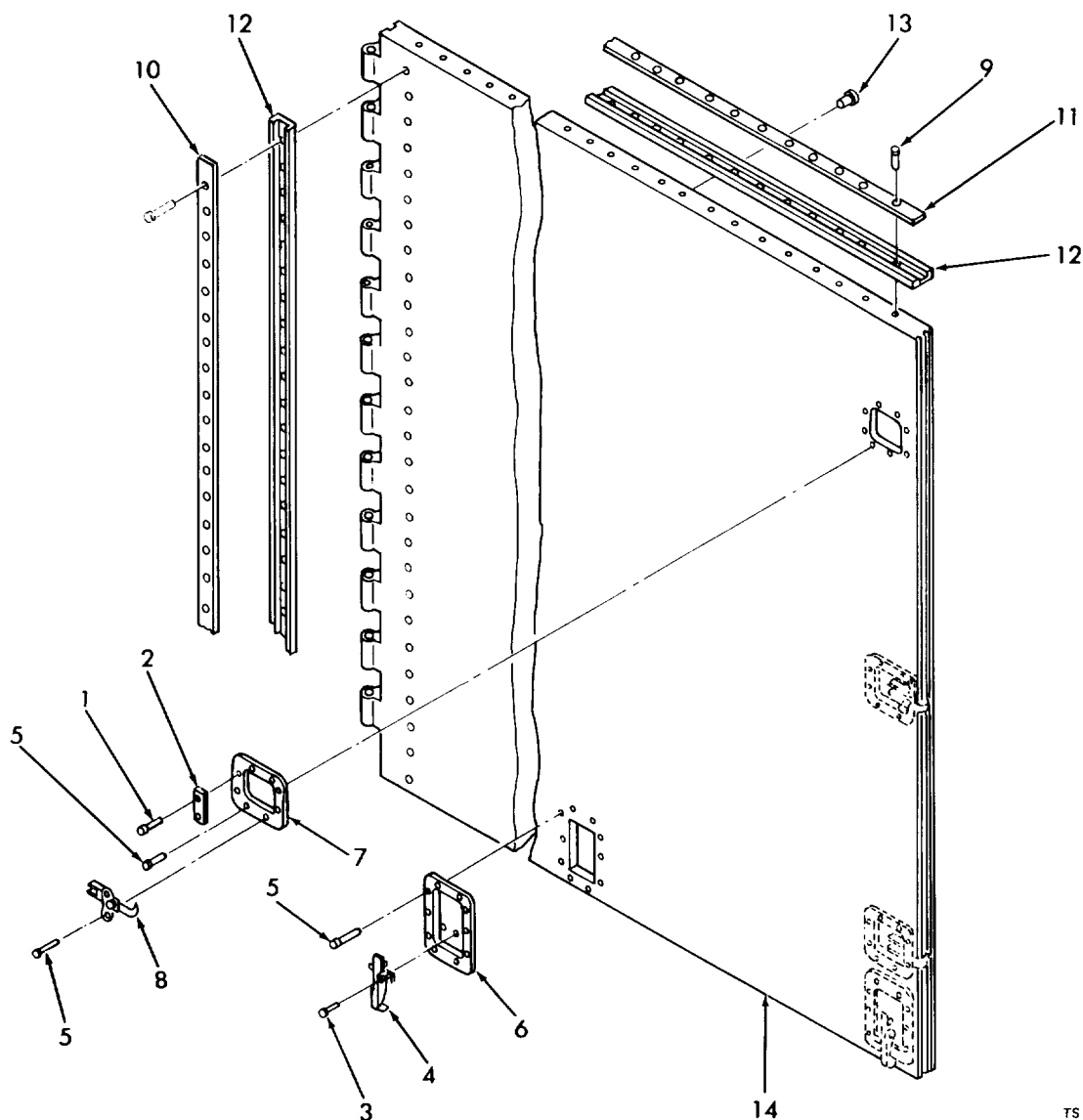

TS 023687

- |               |                 |
|---------------|-----------------|
| 1. Rivet (4)  | 8. Latch (3)    |
| 2. Pad (2)    | 9. Rivet (84)   |
| 3. Rivet (16) | 10. Strip       |
| 4. Latch (4)  | 11. Strip (2)   |
| 5. Rivet (73) | 12. Seal        |
| 6. Pan (4)    | 13. Insert (12) |
| 7. Pan (3)    | 14. Panel       |

Figure 4-2. Swingout wall assembly

(4) Using roof support struts, raise and support roof about two inches for clearance.

(5) Release three latches (8, fig. 4-2) securing swingout wall panel (to be removed) to foldout end wall and release two latches (4) securing swingout wall to foldout floor panel.

(6) Support swingout wall and remove from

hinge (9, figure 4-4) connected between fixed end panel of center structure and swingout wall by drilling out rivets and removing screws from swingout wall.

(7) Carefully remove the swingout wall from the expandable shelter.

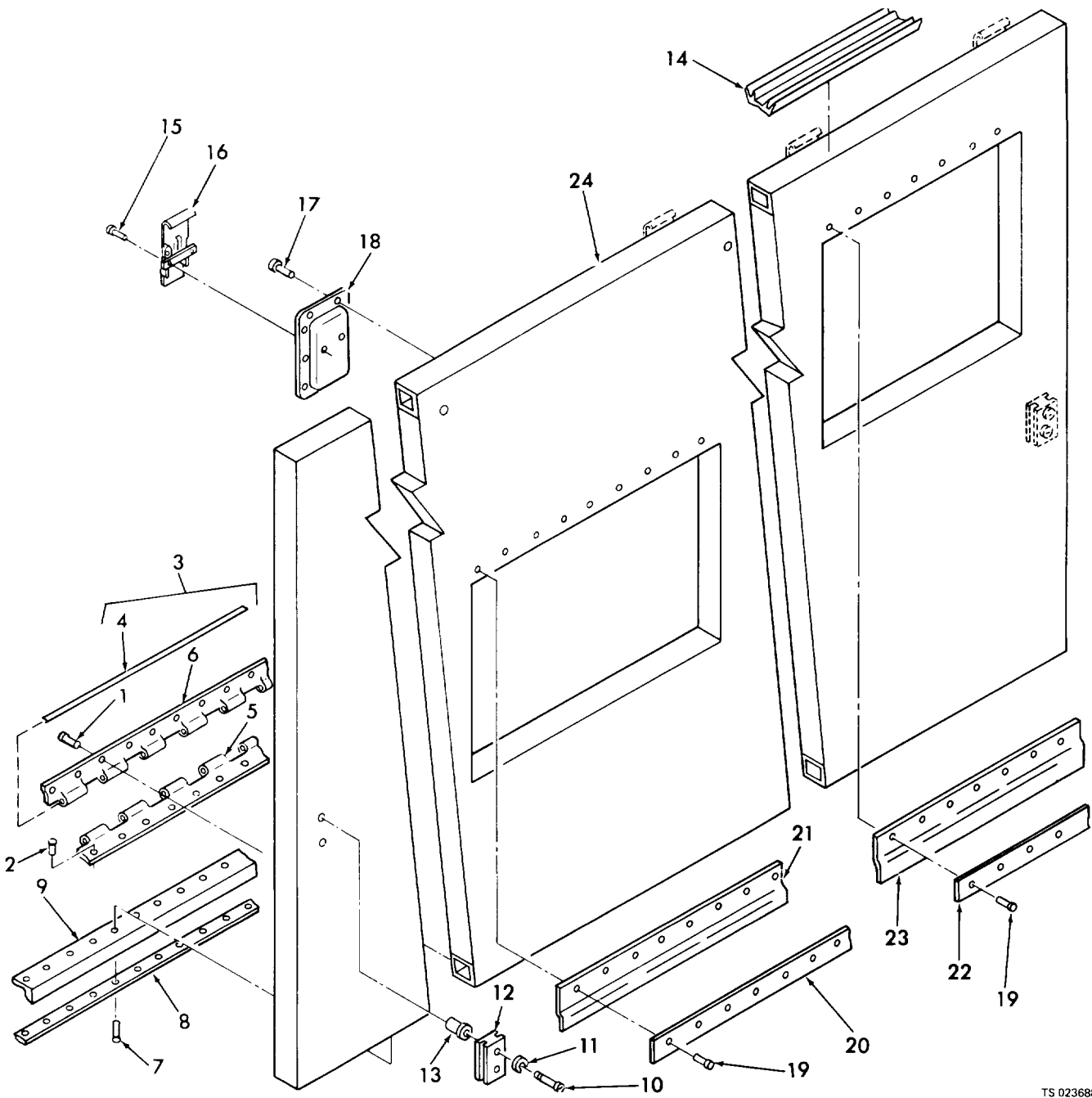

TS 023688

- |                   |                |
|-------------------|----------------|
| 1. Rivet (40)     | 13. Insert (4) |
| 2. Rivet (40)     | 14. Seal       |
| 3. Hinge assembly | 15. Rivet (24) |
| 4. Pin            | 16. Latch (6)  |
| 5. Hinge          | 17. Rivet (60) |
| 6. Hinge          | 18. Pan (6)    |
| 7. Rivet (106)    | 19. Rivet (23) |
| 8. Strip (4)      | 20. Retainer   |
| 9. Seal           | 21. Seal       |
| 10. Screw (4)     | 22. Retainer   |
| 11. Washer (4)    | 23. Seal       |
| 12. Plate (2)     | 24. Panel      |

Figure 4-3. Foldout end wall assembly



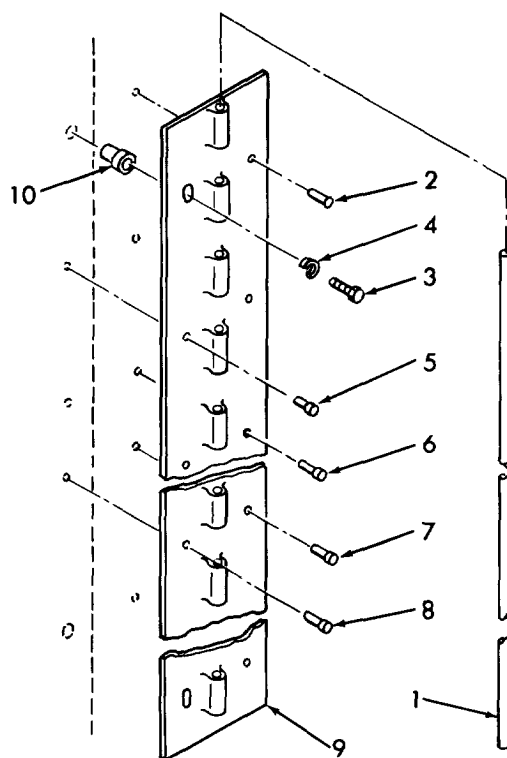

TS 023689

- |                 |                 |
|-----------------|-----------------|
| 1. Pin          | 6. Rivet (31)   |
| 2. Fastener (2) | 7. Fastener (2) |
| 3. screw (2)    | 8. Fastener (2) |
| 4. Washer (2)   | 9. Hinge        |
| 5. Rivet (31)   | 10. Nut (2)     |

Figure 4-4. Swingout wall hinge

*b. Installation.* To install the swingout walls on the expandable shelter perform the following procedure:

(1) Carefully place swingout wall on expandable shelter so that it aligns with the hinge on the center structure end panel.

(2) Support swingout wall and attach to hinge with screws and rivets.

(3) Secure swingout wall to foldout floor panel and foldout end wall using two latches (4, fig. 4-2) and three latches (8).

(4) Using roof support struts, lower hinged roof panel until it rests on swingout walls and foldout end wall.

(5) Remove struts from roof, and place them in stowed position on side of shelter. Pin struts to secure.

(6) Secure foldout roof panel to both swingout walls and foldout end wall using two latches (4, fig. 4-2) on each swingout wall and six latches (16, fig. 4-3) on the foldout end wall.

(7) Reconnect tie down cables.

(8) Reconnect electrical cabling and components in accordance with table 2-1, and installation procedures of paragraph 3-26c.

(9) Turn all circuit breakers on circuit breaker panel to the on position (see fig. 2-1).

#### 4-12. Foldout End Walls.

*a. Removal.* To remove the foldout end walls from the expandable shelter, perform the following procedure:

(1) Perform preliminary procedure of paragraph 4-10.

(2) Disconnect and remove ECU or ventilation fan from foldout end wall about to be removed.

(3) Release latches (fig. 3-2) securing safety cables to personnel and cargo end panels where foldout end wall is about to be removed.

(4) Remove leveling jacks (fig. 3-4) from corners of expandable shelter where foldout end wall is about to be removed.

(5) Unpin roof support struts from stowed position on one side of expandable shelter. Place struts in position to support foldout roof panel on section where foldout end wall is being removed (fig. 3-9).

(6) Inside shelter, release two latches (4, fig. 4-2) securing foldout roof panel to each swingout

wall. Also, release six latches (16, fig. 4-3) securing foldout end wall to foldout roof panel.

(7) Using roof support struts, raise and support roof about two inches for clearance.

**WARNING**

Support foldout end wall to keep it from falling when latches are released and hinge pin is removed.

(8) Release six latches (8, figure 4-2) securing foldout end wall to swingout walls.

(9) Remove hinge pin (4, figure 4-3) from hinge (3) connected between foldout floor panel and foldout end wall.

(10) Carefully remove foldout end wall from the expandable shelter.

*b. Installation.* To install the foldout end wall on the expandable shelter, perform the following procedure:

(1) Carefully place foldout end wall on expandable shelter so that its hinge half aligns with the hinge half on the hinged floor panel.

**WARNING**

Support foldout end wall to keep it from falling until it is secured to swingout walls by latches provided.

(2) Insert hinge pin (4, fig. 4-3) into hinge (3).

(3) Secure foldout end wall to swingout walls using six latches (8, fig. 4-2).

(4) Install leveling jacks at the two corners of expandable shelter. Refer to figure 3-4 for installation of leveling jacks.

(5) Using roof support struts, lower foldout roof panel until it rests on swingout walls and foldout end wall.

(6) Remove struts from roof, and place them in stowed position on side of shelter. Pin struts to secure.

(7) Secure foldout roof panel to foldout end wall using six latches (16, fig. 4-3).

(8) Reinstall ECU or ventilation fan in the foldout end wall. (Refer to paragraph 3-3f or 3-3g, as required.)

(9) Level shelter using jacks and procedure of paragraph 3-3, step (4).

(10) Reconnect tie down cables.

(11) Reconnect electrical cabling and components in accordance with table 2-1, and installation procedures of paragraph 3-26d.

(12) Turn all circuit breakers on circuit breaker panel to on position (see fig. 2-1).

4-13. Foldout Floor Panels.

*a. Removal.* To remove the foldout floor panels from the expandable shelter, perform the following procedure:

**WARNING**

Make certain foldout roof panel is solidly supported during this operation. Also use good judgement in moving these panels since they are extremely heavy.

(1) Perform preliminary procedure of paragraph 4-7.

(2) On side of expandable shelter where foldout floor panel is about to be removed, fold both swingout walls to stowed position using procedure of paragraph 3-4d., steps 3 and 4, and paragraph 3-4e., steps (1) through (4).

(3) Remove foldout end wall in accordance with removal procedure of paragraph 4-12a., steps 1 through 10.

(4) Support foldout floor panel and remove hinge pin (1, fig. 4-5) from hinge connected between center structure floor panel and foldout floor panel.

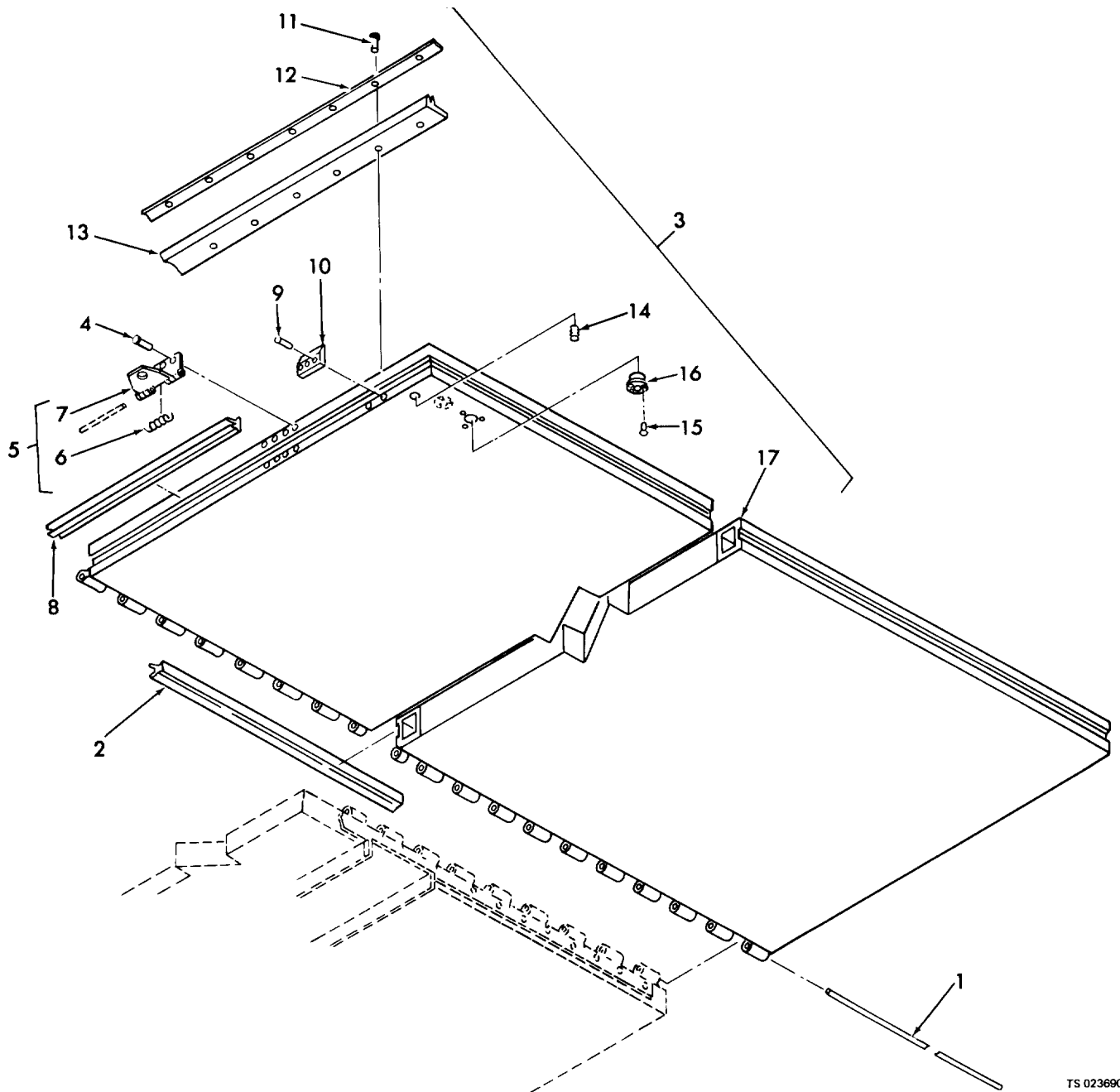

TS 023690

- |                       |                 |
|-----------------------|-----------------|
| 1. Pin (2)            | 10. Strike (2)  |
| 2. Seal               | 11. Rivet (56)  |
| 3. Panel assembly     | 12. strip (2)   |
| 4. Rivet (16)         | 13. Seal        |
| 5. Hinge assembly (2) | 14. Nut (2)     |
| 6. Spring             | 15. Rivet (12)  |
| 7. Hinge              | 16. Grommet (4) |
| 8. Seal               | 17. Panel       |
| 9. Rivet (4)          |                 |

Figure 4-5. Foldout floor panel assembly

(5) Disconnect safety cables (fig. 3-6) from foldout floor panel.

(6) Carefully remove hinged floor panel from expandable shelter.

*b. Installation.* To install the foldout floor panel on expandable shelter, perform the following procedure:

(1) Carefully place the foldout floor panel in expandable shelter so that its hinge half aligns with the hinge half on center structure floor panel.

(2) Support foldout floor panel and insert hinge pin (1, fig. 3-5) into hinge.

(3) Connect safety cables (fig. 3-6) to foldout floor panel.

(4) Swing swingout walls outward to full deployed position. Secure swingout walls to foldout floor panel using four latches (4, figure 4-2) provided.

(5) Install foldout end wall on expandable shelter in accordance with installation procedure of paragraph 4-12b. steps 1 through 10.

#### 4-14. Foldout Roof Panels.

*a. Removal.* To remove the foldout roof panels from the expandable shelter, perform the following procedure:

(1) Perform preliminary procedure of paragraph 4-10.

(2) Inside shelter, release two latches (4, fig. 4-2) securing foldout roof panel (about to be removed) to each swingout wall and release six latches (16, fig. 4-3) securing foldout roof panel to foldout end wall.

#### **WARNING**

**Have at least four men support hinged roof panel in the following step.**

(3) Fold in swingout walls and foldout end wall then lower foldout roof panel.

(4) Remove hinge pin (1, figure 4-6) from hinge connected between foldout roof panel and center structure roof panel.

(5) Carefully remove foldout roof panel from expandable shelter.

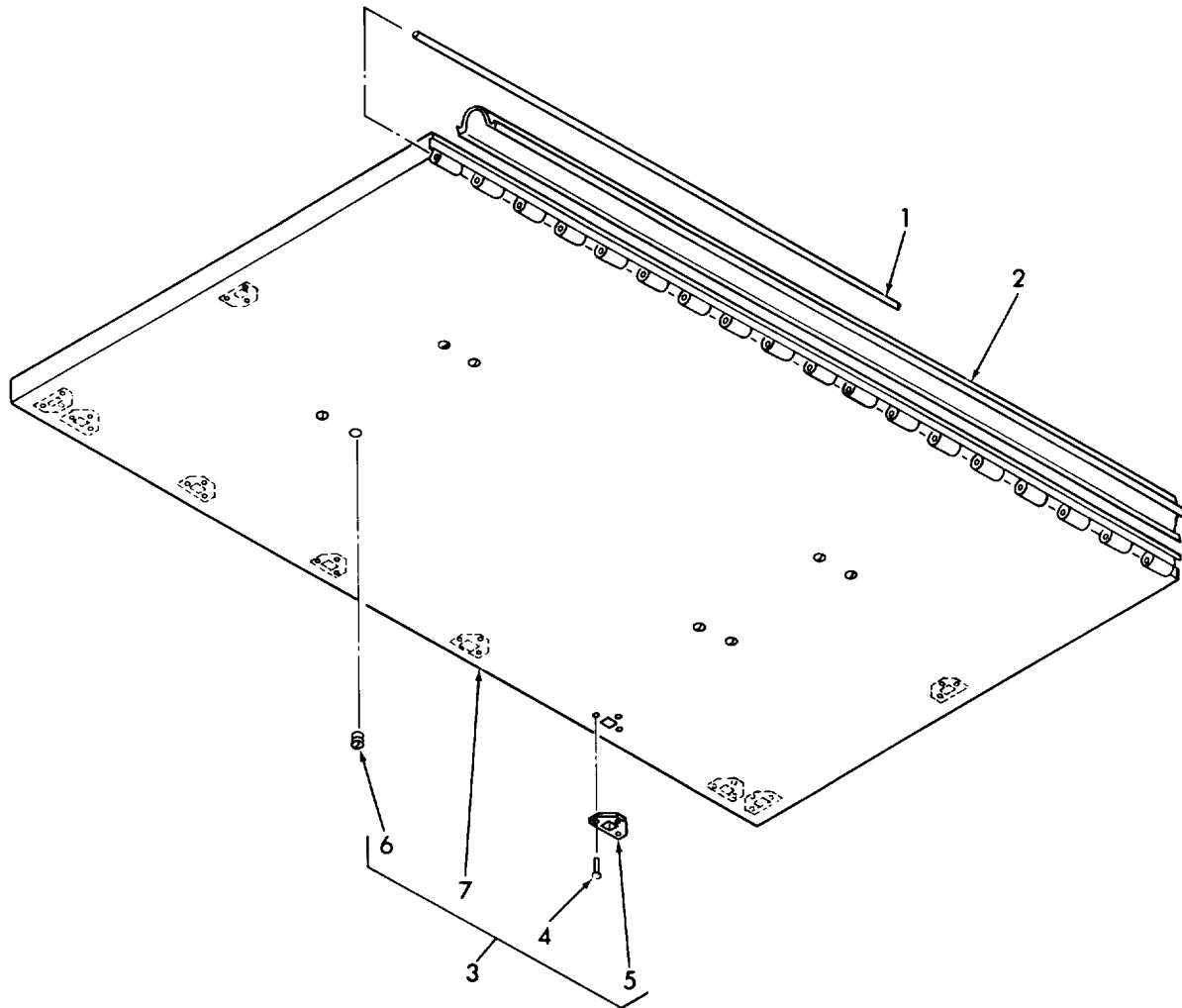

TS 023691

- |                  |                         |
|------------------|-------------------------|
| 1. Pin (2)       | 5. Cup (10)             |
| 2. seal          | 6. Fitting assembly (8) |
| 3. Roof assembly | 7. Panel                |
| 4. Rivet (30)    |                         |

Figure 4-6. Foldout roof panel assembly

*b. Installation.* To install the foldout roof panels on the expandable shelter, perform the following procedure:

(1) Carefully place foldout roof panel on expandable shelter so that its hinge half aligns with the hinge half on the center structure roof panel.

(2) Insert hinge pin (1, fig. 4-6) into hinge.

**WARNING**

Have at least four men support hinged roof panel in the following step.

(3) Swing up foldout roof panel and foldout swingout walls and foldout end wall. Secure foldout roof panel to both swingout walls using four latches (4, fig. 4-2) and to foldout end wall using six latches (16, fig. 4-3).

(4) Reconnect tie down cables.

(5) Reconnect electrical cabling in accordance with table 2-1, and turn all circuit breakers on circuit breaker panel back on (see fig. 2-1).

**4-15. Electrical System Circuit Breaker Panel.**

**WARNING**

**The expandable shelter contains voltages that are dangerous if contacted. Before removing or installing electrical cables or components, make certain electrical power is completely disconnected.**

*a. Removal.*

(1) Tag disconnected leads to ensure proper connection.

(2) Set all circuit breakers on circuit breaker panel to off position.

**[WARNING]**

**Site power must be disconnected from the power entrance panel by a qualified electrician.**

(3) Disconnect site power from power entrance panel (refer to paragraph 3-4, step b.).

(4) Disconnect five cables from top of circuit breaker panel (6, fig. 4-7). It is not necessary to disconnect light at top of circuit breaker panel.

(5) Remove four screws to remove panelboard cover (10).

(6) Disconnect five leads from circuit breaker CB1 (4).

(7) Remove eight screws (11) and washers (12 and 13) securing circuit breaker panel to shelter wall.

(8) Remove circuit breaker panel.

*b. Installation,*

(1) Place circuit breaker panel (6, fig. 4-7) in position on inside rear of electrical power entrance panel (fig. 3-1) on personnel end panel.

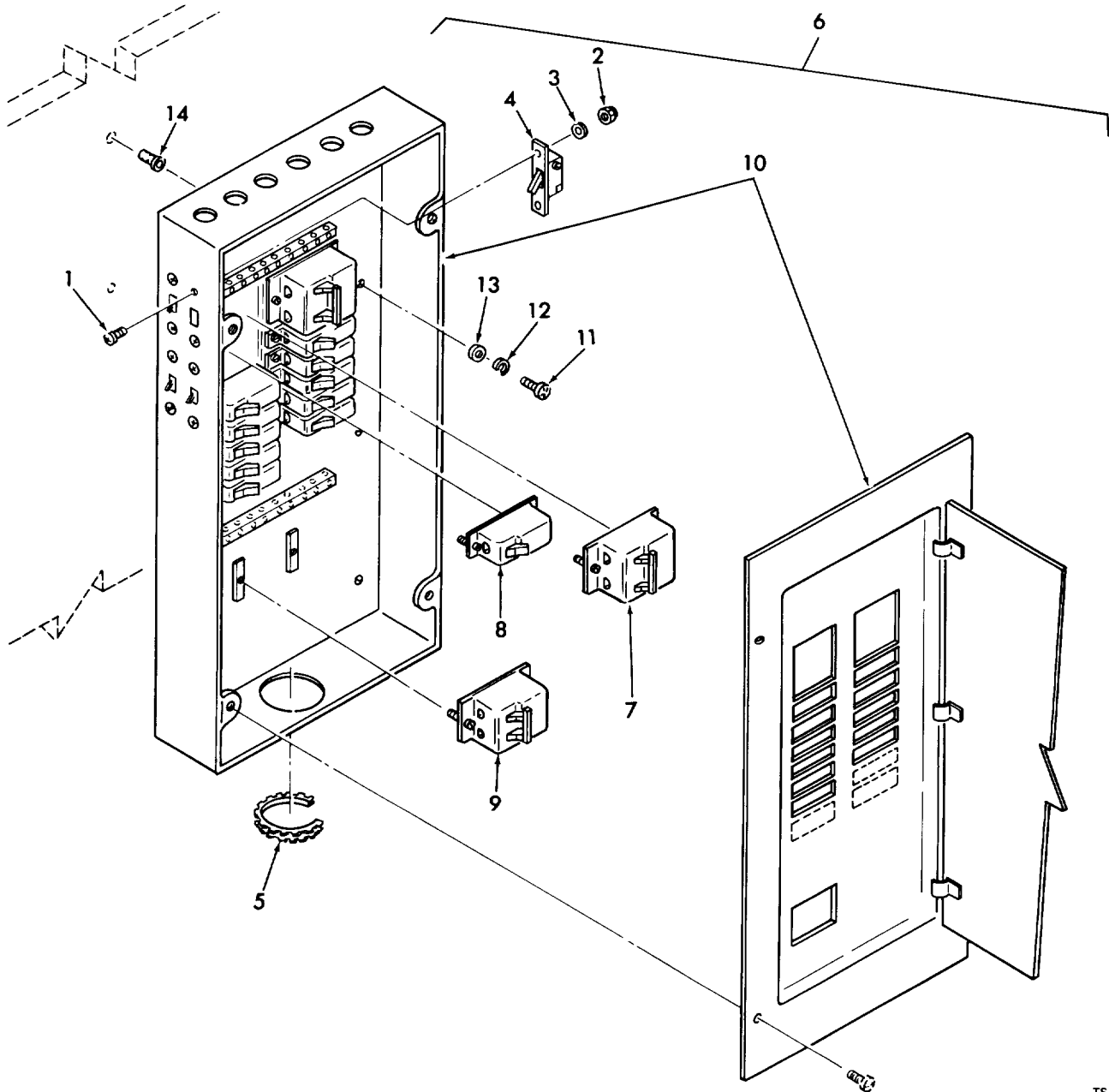

Figure 4-7. Circuit breaker panel assembly

TS 023692

KEY to figure 4-7:

- |                                   |                         |
|-----------------------------------|-------------------------|
| 1. Screw (8)                      | 8. Circuit breaker (11) |
| 2. Nut (8)                        | 9. Circuit breaker      |
| 3. Washer (8)                     | 10. Panelboard          |
| 4. Switch (4)                     | 11. Screw (8)           |
| 5. Grommet                        | 12. Washer (8)          |
| 6. Circuit breaker panel assembly | 13. Washer (8)          |
| 7. Circuit breaker (2)            | 14. Insert (8)          |

(2) Secure circuit breaker panel to shelter wall using eight screws (11, fig. 4-7) and washers (12 and 13).

(3) Reconnect five leads to circuit breaker CBI (4).

(4) Place panelboard cover in position on circuit breaker panel and secure using attaching screws and washers.

(5) Reconnect five cables to top of circuit breaker panel.

**WARNING**

Site power must be reconnected by a qualified electrician.

(6) Reconnect site power to expandable shelter (refer to paragraph 3-3*d.*, step (2)).

(7) Set all circuit breakers on circuit breaker panel to on position.

(8) Remove all tags.





CHAPTER 5

REPAIR OF SWINGOUT WALLS

**5-1. Description.**

The description of the swingout walls is contained in paragraph 3-17.

**5-2. Removal.**

Most swingout wall repairs can be accomplished without removing the wall from the shelter. Therefore, do not remove the wall unless it is absolutely necessary.

**5-3. Cleaning.**

Use a clean, soft bristle brush to remove dust, dirt, and lint from all parts and surfaces of the walls. Wash panels with soap and water, and a sponge or soft cloth.

**5-4. Inspection and Repair.**

a. *Inspection.* Inspection of the swingout walls is accomplished by performing the following procedure:

- (1) Check for surface damage or corrosion.
- (2) Check for damage to core material.
- (3) Check for proper installation of thermal barriers.
- (4) Check condition of paint.
- (5) Check latches, hinges, and movable parts for ease of operation and damage.
- (6) Check for poor or no seals.
- (7) Check all fasteners for security of attachment.
- (8) Check for faulty riveting and bonding.
- (9) Check legibility of markers.
- (10) Check for other obvious damage.

b. *Repair.* If a swingout wall has minor structural damage, repair the wall in accordance with procedures given in paragraph 3-16. If a wall has major damage, replace the entire wall making sure that the new wall meets the requirements of Brunswick drawings. If a part attached to a swingout wall is damaged, remove and replace the damaged part as follows:

- (1) Removal and replacement of latch and pan (fig. 4-2). To remove and replace latch (4 or 8) and pan (6 or 7), proceed as follows:
  - (a) Remove four rivets (3) to detach latch (4) from swingout wall.

**NOTE**

Refer to paragraph 4-7 for rivet removal and replacement procedures.

(b) Remove 10 rivets (5) to detach pan (6) from swingout wall.

(c) Remove three rivets (5) to detach latch (8) from swingout wall.

(d) Remove eight rivets (5) to detach pan (7) from swingout wall.

(e) Attach new pan (6 or 7) using 10 rivets (5) or eight rivets (5), respectively.

(f) Attach new latch (4 or 8) using four rivets (3) or three rivets (5), respectively.

(2) Removal and replacement of bumper pad (fig. 4-2). To remove and replace bumper pad (2), proceed as follows:

(a) Remove two rivets (1) to detach bumper pad (2).

**NOTE**

Refer to paragraph 4-7 for rivet removal and replacement procedures.

(b) Replace bumper pad (2) by securing to swingout wall using two rivets (1).

(3) Removal and replacement of seal (fig. 4-2). To remove and replace seal (12), proceed as follows:

(a) Remove rivets (9) to detach seal strip (10 or 11).

**NOTE**

Refer to paragraph 4-7 for rivet removal and replacement procedures.

(b) Remove and replace seal (12) in accordance with instructions given in paragraph 3-16e.

(c) Re-attach seal strip (10 or 11) using rivets (9).

(4) Removal and replacement of inserts (fig. 4-2). To remove and replace inserts (13), follow instructions given in paragraph 4-8.

**5-5. Installation.**

If entire swingout wall is to be replaced, refer to the installation procedure contained in paragraph 4-11b.



## CHAPTER 6

## REPAIR OF FOLDOUT END WALLS

**6-1. Description.**

The description of the foldout end walls is contained in paragraph 3-18.

**6-2. Removal.**

Most foldout end wall repairs can be accomplished without removing the wall from the shelter. Therefore, do not remove the wall unless it is absolutely necessary.

**6-3. Cleaning.**

Use a clean, soft bristle brush to remove dust, dirt, and lint from all parts and surfaces of the sidewall. Wash walls with soap and water, and a sponge or soft cloth.

**6-4. Inspection and Repair.**

*a. Inspection.* Inspection of the foldout end walls is accomplished by performing the following procedure:

(1) Perform inspection procedure of paragraph 5-4a., steps 1 through 10.

(2) Check condition of ventilation fan and air conditioner panels.

*b. Repair.* If a foldout end wall has minor structural damage, repair the wall in accordance with procedures given in paragraph 3-16. If a wall has major damage, replace the entire wall making sure that the new wall meets the requirements of Brunswick drawings. If a part attached to a foldout end wall is damaged, remove and replace the damaged part as follows:

(1) Removal and replacement of hinge (fig. 4-3). To remove and replace hinge (3), proceed as follows:

(a) Remove 40 rivets (1) to detach hinge half (6).

**NOTE**

Refer to paragraph 4-7 for rivet removal and replacement procedures.

(b) Remove 40 rivets (2) to detach hinge half (5).

(c) Replace both hinge (3) halves (5 and 6) by securing with 40 rivets (2) and 40 rivets (1), respectively.

(2) Removal and replacement of seal (fig. 4-3). To remove and replace seal (9), proceed as follows:

(a) Remove rivets (7) to detach seal strip (8).

**NOTE**

Refer to paragraph 4-7 for rivet removal and replacement procedures.

(b) Remove and replace seal (9) in accordance with instructions given in paragraph 3-16e.

(c) Re-attach seal strip (8) using rivets (7).

(3) Removal and replacement of latch and pan (fig. 4-3). To remove and replace latch (17) or pan (19), proceed as follows:

(a) Remove four rivets (15) to detach latch (16).

**NOTE**

Refer to paragraph 4-7 for rivet removal and replacement procedures.

(b) Remove 10 rivets (17) to detach pan (18).

(c) Replace pan (18) by securing to foldout end wall using 10 rivets (17).

(d) Replace latch (16) by securing to foldout end wall using four rivets (15).

(4) Removal and replacement of seal frame assembly (fig. 6-1). To remove and replace seal frame assembly (5), proceed as follows:

(a) Detach seal frame assembly (5) from foldout end wall.

(b) Refer to paragraph 3-16 for seal removal and replacement instructions.

(c) Replace seal rubber (6) in seal frame (7) and secure seal frame assembly in foldout end wall.

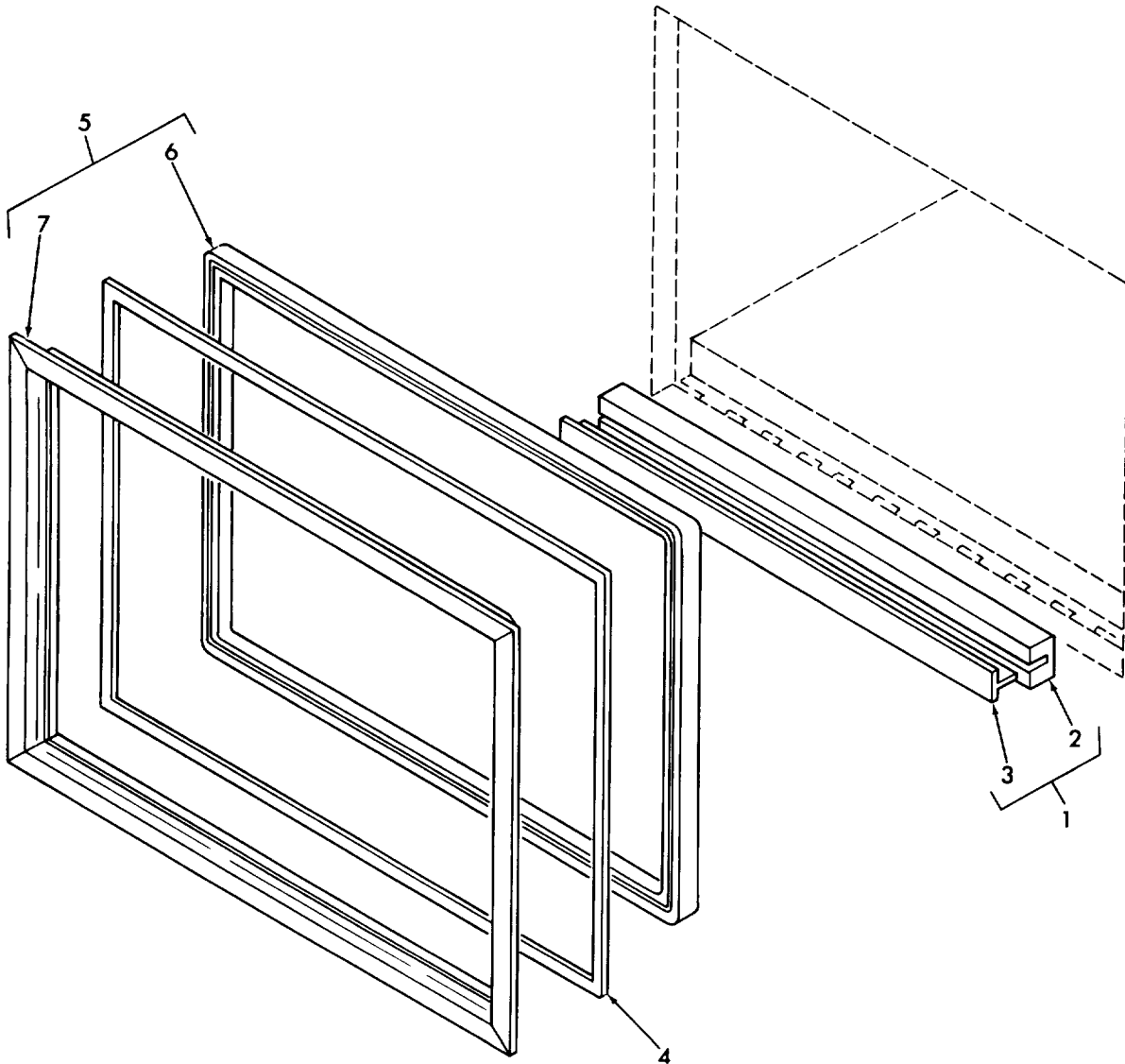

TS 023693

- 1. Seal assembly
- 2. Seal
- 3. Plate
- 4. Seal

- 5. Frame assembly
- 6. Seal
- 7. Frame

Figure 6-1. Seal and frame assembly

(5) Removal and replacement of jack support plate (fig. 4-3). To remove and replace jack support plate (12), proceed as follows:

- (a) Remove jack from jack support plate (12).
- (b) Remove two screws (10) and washers (11) to detach jack support plate.
- (c) Replace jack support plate (12) by securing to foldout end wall using two screws (10) and washers (11).

(d) Install jack in accordance with paragraph 3-3a(3).

(6) Removal and replacement of inserts (fig. 4-3). To remove and replace inserts (13), follow instructions given in paragraph 4-8.

(7) Remove and replace ECU panel (fig. 6-2). To remove and replace ECU panel (31), proceed as follows:

- (a) Detach cable (6) from foldout end wall by removing screw (1) and shoulder washers (3 and 4).
- (b) Remove seven rivets (7) from hinge (10) and remove ECU panel (31) from foldout end wall.

**NOTE**

Refer to paragraph 4-7 for rivet removal and replacement procedures.

(c) Replace ECU panel (31) by attaching hinge to foldout end wall using rivets (7).

(d) Re-attach cable (6) to foldout end wall with screw (1) and shoulder washers (2 and 3).

(8) Removal and replacement of closure assembly (figure 6-2). To remove and replace closure assembly (12) and associated parts, proceed as follows:

(a) Remove closure assembly (12) from holes in ECU panel (31) and disassemble by removing screw (15).

(b) Separate seal (17) and rear plate (20) from front plate (16).

(c) Using new seal (17), reassemble closure assembly (12) and secure with screw (15).

(d) Insert closure assembly (12) into ECU panel (31).

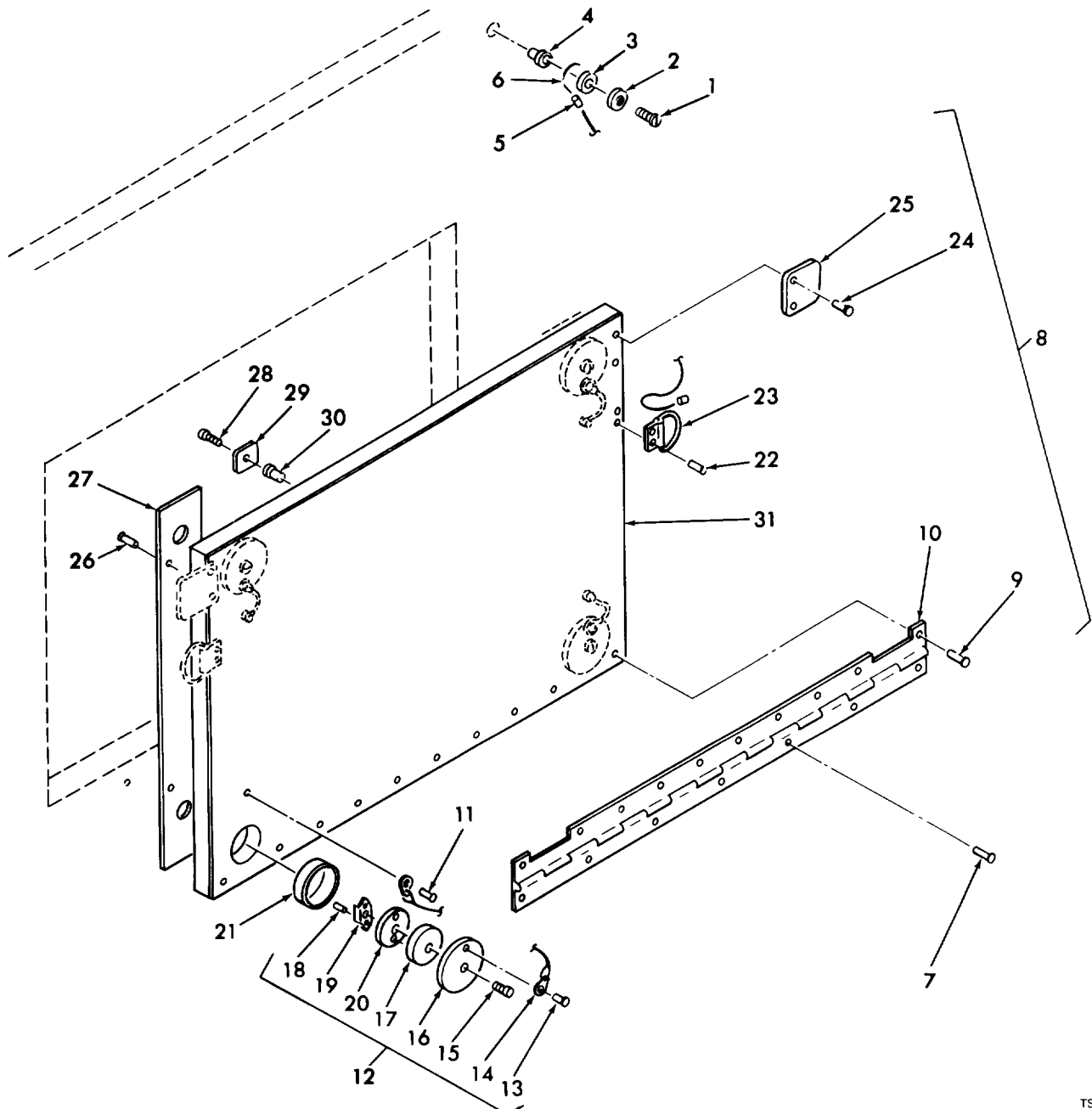

- 1. Screw (2)
- 2. Washer (2)
- 3. Washer (2)
- 4. Nut (2)
- 5. Sleeve (2)
- 6. Cable (2)
- 7. Rivet (7)
- 8. Panel assembly

- 9. Rivet (10)
- 10. Hinge
- 11. Rivet (4)
- 12. Closure assembly (4)
- 13. Rivet
- 14. Lanyard
- 15. Screw

- 16. Plate
- 17. Seal
- 18. Rivet (2)
- 19. Nut
- 20. Plate
- 21. Sleeve (4)
- 22. Rivet (4)

- 23. Ring (2)
- 24. Rivet (4)
- 25. Rivet (8)
- 26. Spacer (2)
- 27. Screw (2)
- 28. Plate (2)
- 29. Nut (2)
- 30. Panel

Figure 6-2. ECU panel assembly

TS 023694

(9) Removal and replacement of hinge (fig. 6-2). To remove and replace hinge (10), proceed as follows:

(a) Remove ECU panel as described in subparagraph 6-4b(7).

(b) Remove 10 rivets (9) to detach hinge (10) from ECU panel (31).

**NOTE**

Refer to paragraph 4-7 for rivet removal and replacement procedures.

(c) Replace hinge (10) by securing to ECU panel (31) with 10 rivets (9).

(d) Replace ECU panel as described in subparagraph 6-4b(7).

(10) Removal and replacement of retainer plates (fig. 6-2). To remove and replace retainer plates (25), proceed as follows:

(a) Remove two rivets (24) to detach retainer plate (25).

**NOTE**

Refer to paragraph 4-7 for rivet removal and replacement procedures.

(b) Replace retainer plate (25) by securing to ECU panel using two rivets (24).

(11) Removal and replacement of lock plate (fig. 6-2). To remove and replace lock plate (29), proceed as follows:

(a) Remove screw (28) to detach lock plate (29).

(b) Replace lock plate (29) by securing to ECU panel using screw (28).

**6-5. Installation.**

If entire foldout end wall is to be replaced, refer to the installation procedure contained in paragraph 4-12b.

## CHAPTER 7

## REPAIR OF FOLDOUT FLOOR PANELS

**7-1. Description.**

The description of the foldout floor panels is contained in paragraph 3-20.

**7-2. Removal.**

Most foldout floor panel repair can be accomplished without removing the panel from the shelter. Therefore, do not remove the foldout floor panels unless it is absolutely necessary.

**7-3. Cleaning**

Use a clean, soft bristle brush to remove dust, dirt, and lint from all parts and surfaces of the foldout floor panels. Wash floors by scrubbing with soap, clean water, and a mop.

**7-4. Inspection and Repair.**

a. **Inspection.** Inspection of the foldout floor panels is accomplished by performing the following procedure:

- (1) Perform inspection procedure of paragraph 5-4a., steps 1 through 10.
- (2) Check strikes for security of attachment.

b. **Repair.** If a foldout floor panel has minor structural damage, repair the panel in accordance with procedures given in paragraph 3-16. If a panel has major damage, replace the entire panel making sure that the new panels meets the requirements of Brunswick drawings. If a part attached to a foldout floor panel is damaged, remove and replace the damaged parts as follows:

- (1) Removal and replacement of seal (fig. 4-5). To remove and replace seals (8 and 13), proceed as follows:

- (a) Remove rivets (11) to detach seal strip (12).

**NOTE**

Refer to paragraph 4-7 for rivet removal and replacement procedure.

- (b) Remove and replace seal (8 or 13) in accordance with instruction given in paragraph 3-16e.

- (c) Re-attach seal strip (12) using rivets (11).

(2) **Removal and replacement of hinge assembly (fig. 4-5).** To remove and replace hinge assembly (5), proceed as follows:

- (a) Remove four rivets (4) to detach hinge assembly (5).

(b) Replace hinge assembly (5) by securing to foldout floor panel (17) using four rivets (4).

(3) **Removal and replacement of strike (fig. 4-5).** To remove and replace strike (10), proceed as follows:

- (a) Remove two rivets (9) to detach strike (10).

**NOTE**

Refer to paragraph 4-7 for rivet removal and replacement procedure.

(b) Replace strike (10) by securing to foldout floor panel (17) using two rivets (9).

**7-5. Installation.**

If entire foldout floor panel is to be replaced, refer to the installation procedure contained in paragraph 4-13b.





## CHAPTER 8

## REPAIR OF FOLDOUT ROOF PANELS

**8-1. Description.**

The description of the foldout roof panels is contained in paragraph 3-21.

**8-2. Removal.**

Most foldout roof panel repairs can be accomplished without removing the panel from the shelter. Therefore, do not remove the foldout roof panel unless it is absolutely necessary.

**8-3. Cleaning.**

Use a clean, soft bristle brush to remove dust, dirt, and lint from all parts and surfaces of the foldout roof panels. Wash roof with soap and water, and a sponge or soft cloth.

**8-4. Inspection and Repair.**

*a. Inspection.* Inspection of the foldout roof panels is accomplished by performing the following procedure:

(1) Perform inspection procedure of paragraph 5-4a., steps 1 through 9.

(2) Check strike cups and support strut brackets for security of attachment.

*b. Repair.* If a foldout roof panel has minor structural damage, repair the panel in accordance with procedures given in paragraph 3-16. If a panel has major damage, replace the entire panel making

sure that the new panel meets the requirements of Brunswick drawings. If a part attached to a foldout roof panel is damaged, remove and replace the damaged part as follows:

(1) Removal and replacement of strike cup (fig. 4-6). To remove and replace strike cup (5), proceed as follows:

(a) Remove three rivets (4) to detach strike cup (5).

**NOTE**

Refer to paragraph 4-7 for rivet removal and replacement procedure.

(b) Replace strike cup (5) by securing to foldout roof panel using three rivets (4).

(2) Removal and replacement of strut yoke (fig. 8-1). To remove and replace strut support (15) and strut yoke (12), proceed as follows:

(a) Remove support strut (3) from strut yoke (12) by removing pin (2).

(b) Remove screw (11) to detach strut yoke (12).

(c) Replace strut yoke (12) by securing to strut support (15) using screw (11).

(d) Replace support strut (3) by securing to strut yoke using pin (2).

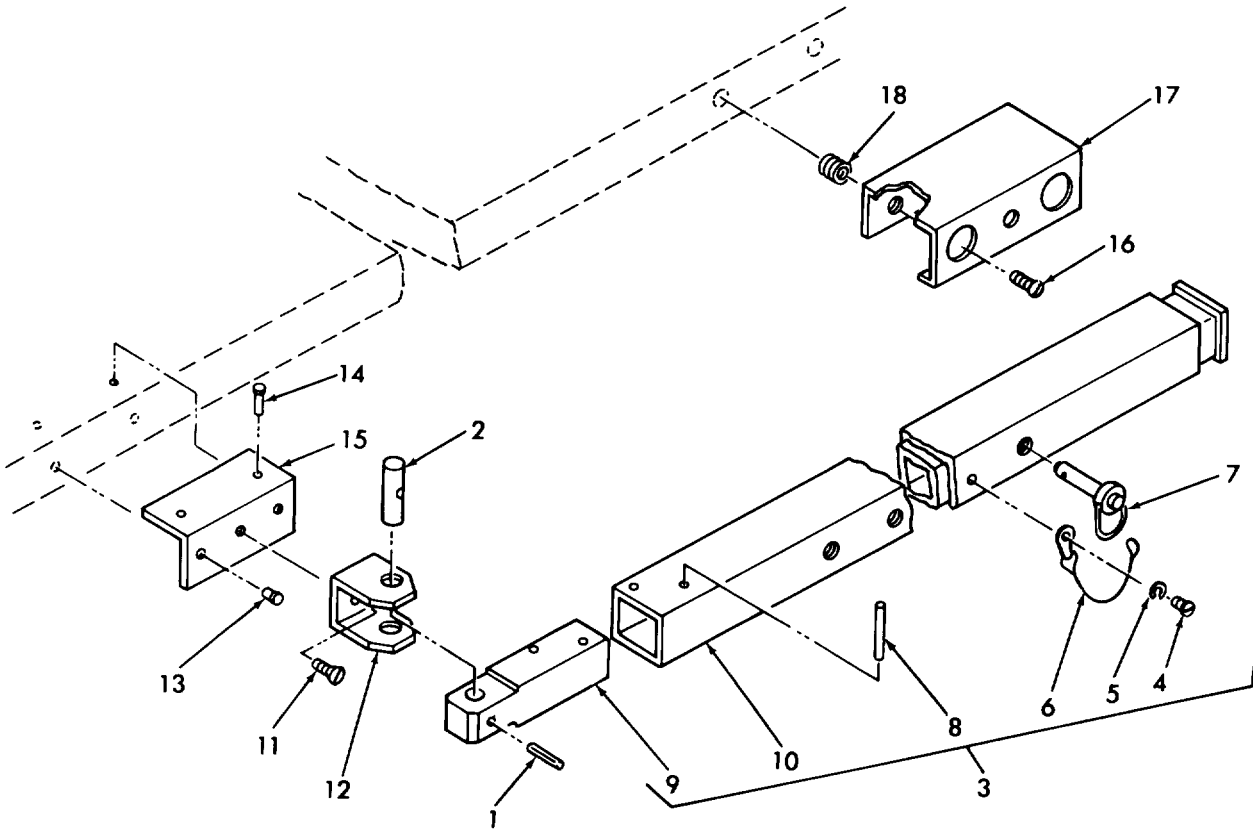

TS 023695

- |                           |                  |
|---------------------------|------------------|
| 1. Pin                    | 10. Tube         |
| 2. Pin                    | 11. screw        |
| 3. Support strut assembly | 12. Yoke         |
| 4. Screw                  | 13. Fastener (2) |
| 5. Washer                 | 14. Fastener (2) |
| 6. Lanyard assembly       | 15. Support      |
| 7. Pin                    | 16. Screw (2)    |
| 8. Rivet (2)              | 17. Support      |
| 9. Bar                    | 18. Nut (2)      |

Figure 8-1. Support strut assembly and related parts

**8-5. Installation.**

If entire foldout roof panel is to be replaced, refer to the installation procedure contained in paragraph 4-146.

## CHAPTER 9

REPAIR OF CENTER STRUCTURE ROOF PANEL

---

**9-1. Description.**

The description of the center structure roof panel is contained in paragraph 3-22.

**9-2. Cleaning.**

Use a clean, soft bristle brush to remove dust, dirt, and lint from all parts and surfaces of the roof panel. Wash roof with soap and water, and a sponge or soft cloth.

**9-3. Inspection and Repair.**

a. Inspection. Inspection of the center structure roof panel is accomplished by performing the following procedure:

(1) Perform inspection procedure of paragraph 5-4a., steps 1 through 10.

(2) Check handle and plate, and drop pad at top of roof for security of attachment and damage.

b. Repair. If the center structure roof panel has minor structural damage, repair the panel in accordance with procedures given in paragraph 3-16. If a part attached to the center structure roof panel is damaged, remove and replace the damaged part as follows:

(1) Removal and replacement of handle and

plate (fig. 9-1). To remove and replace handle and plate (8), proceed as follows:

(a) Remove four rivets (7) to detach handle and plate (8).

**NOTE**

Refer to paragraph 4-7 for rivet removal and replacement procedures.

(b) Replace handle and plate (8) by securing to center structure roof panel (16) using four rivets (7).

(2) Removal and replacement of scuff plate (fig. 9-1). To remove and replace scuff plate (11), proceed as follows:

(a) Remove four rivets (10) to detach scuff plate (11).

**NOTE**

Refer to paragraph 4-7 for rivet removal and replacement procedures.

(b) Replace scuff plate (11) by securing to center structure roof panel (16) by using four rivets (10).

(3) Removal and replacement of inserts (fig. 9-1). To remove and replace inserts (9, 14, and 15), follow instructions given in paragraph 4-8.

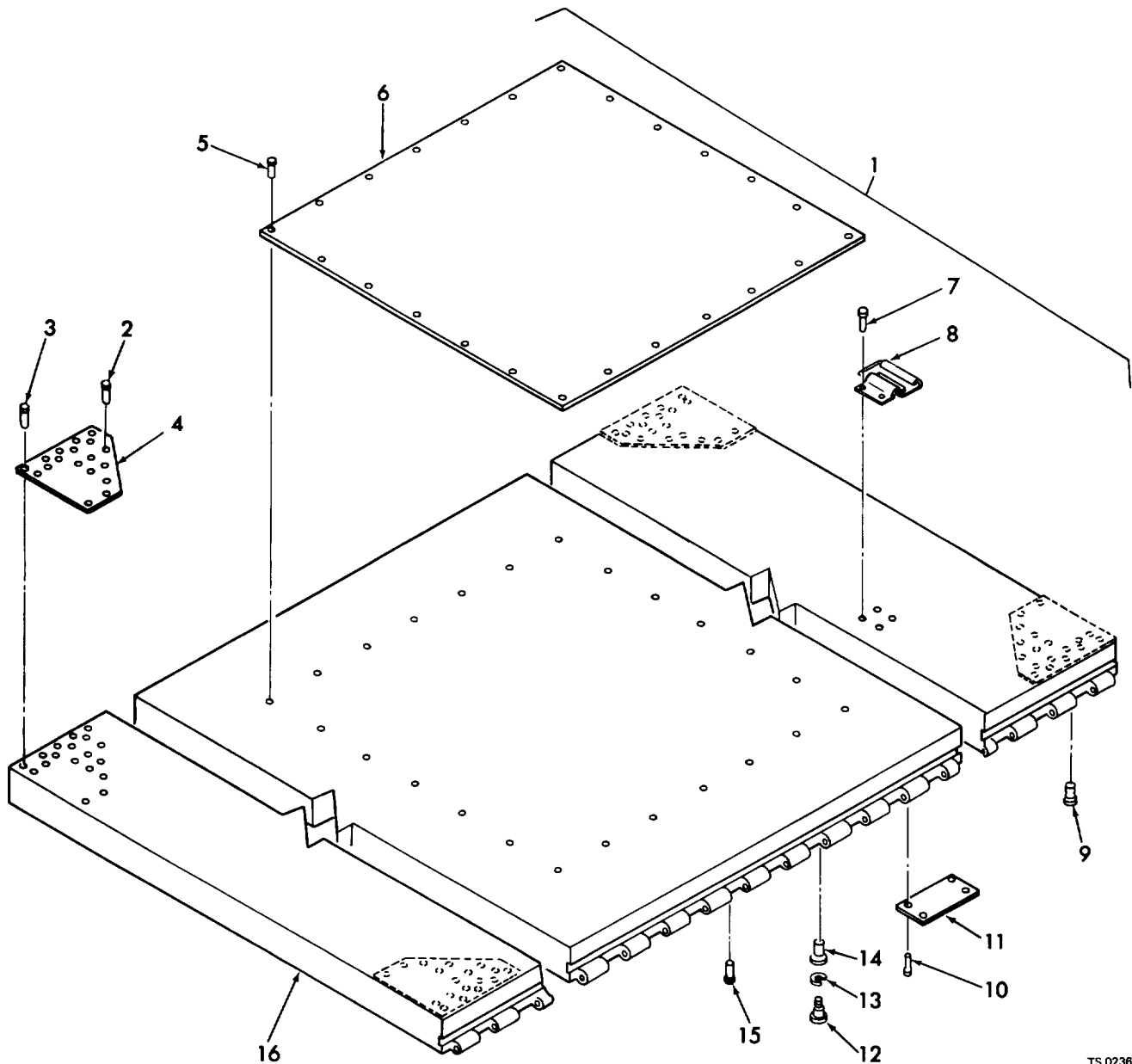

TS 023896

- |                        |                      |
|------------------------|----------------------|
| 1. Fixed roof assembly | 9. Insert (4)        |
| 2. Rivet (24)          | 10. Rivet (48)       |
| 3. Rivet (48)          | 11. Scuff plate (12) |
| 4. Plate (4)           | 12. Stud (24)        |
| 5. Rivet (24)          | 13. Washer (24)      |
| 6. Drop pad            | 14. Insert (38)      |
| 7. Rivet (4)           | 15. Insert (8)       |
| 8. Handle              | 16. Panel assembly   |

Figure 9-1. Center structure roof panel assembly

(4) Removal and replacement of fan storage bracket (fig. 9-2). To remove and replace fan storage bracket (4 or 5), proceed as follows:

(a) Remove two screws (1), lock washers (2), and flat washers (3) to detach bracket (4 or 5).

(b) Replace bracket (4 or 5) by securing to center structure roof panel using two screws (1), lock washers (2), and flat washers (3).

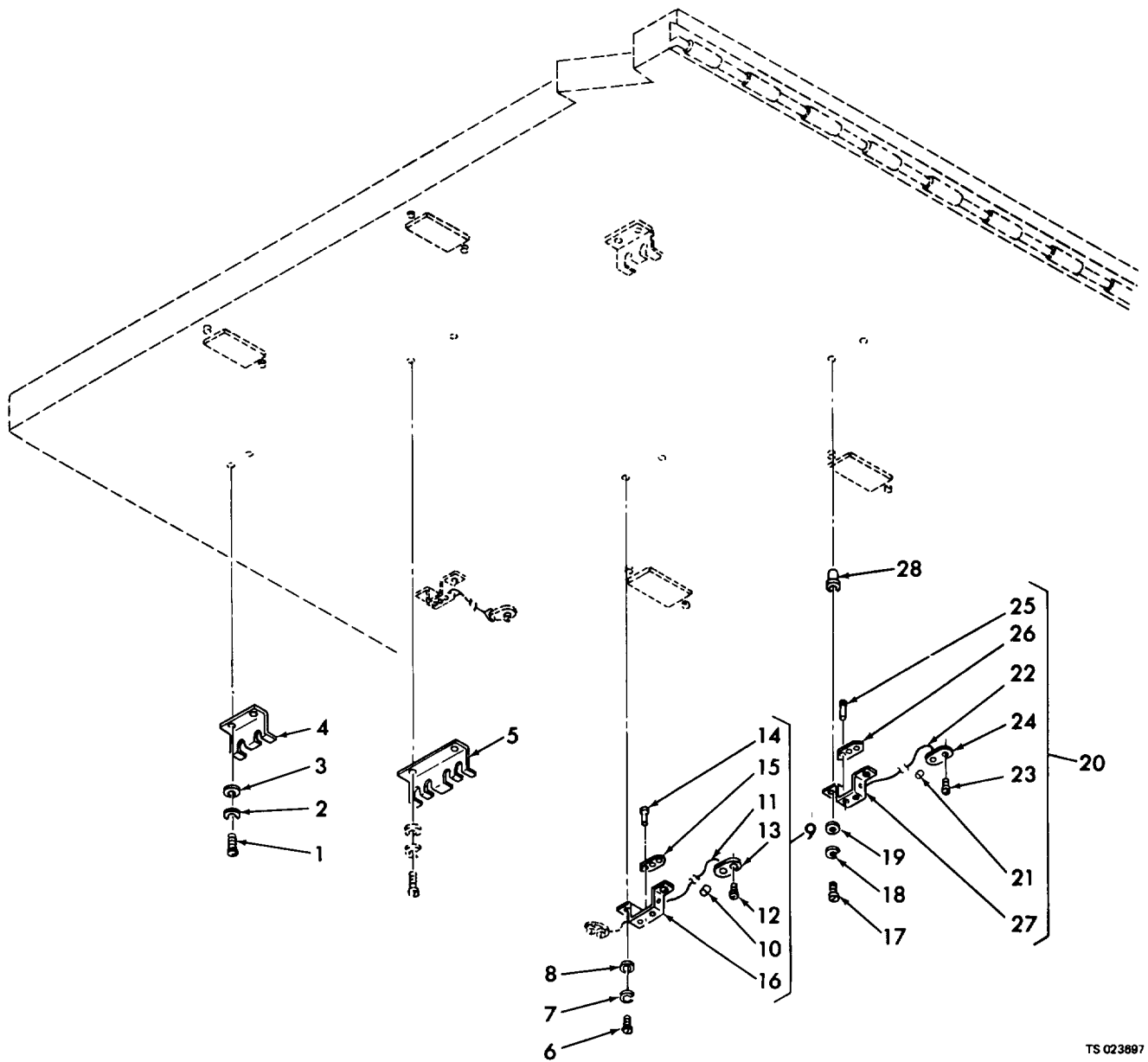

TS 023897

- |                     |                          |
|---------------------|--------------------------|
| 1. Screw (6)        | 15. Nut (2)              |
| 2. Washer (6)       | 16. Standoff             |
| 3. Washer (6)       | 17. screw (4)            |
| 4. Bracket (2)      | 18. Washer (4)           |
| 5. Bracket          | 19. Washer (4)           |
| 6. Screw (2)        | 20. Support assembly (2) |
| 7. Washer (2)       | 21. Sleeve (2)           |
| 8. Washer (2)       | 22. wire rope            |
| 9. Support assembly | 23. Fastener             |
| 10. Sleeve (4)      | 24. Retainer             |
| 11. Wire rope (2)   | 25. Rivet (4)            |
| 12. Fastener (2)    | 26. Nut                  |
| 13. Retainer (2)    | 27. Standoff             |
| 14. Rivet (4)       | 28. Insert (12)          |

Figure 9-2. Fan stowage installation

(5) Removal and replacement of support assembly (fig. 9-2 ). To remove and replace support assembly (20 or 9), proceed as follows:

(a) Remove two screws (1), lock washers (2), and flat washers (3) to detach support assembly (20 or 9).

(b) Replace support assembly (20 or 9) by securing to center structure roof panel using two screws (1), lock washers (2), and flat washers (3).

(6) Removal and replacement of ceiling light retainer assembly (fig. 9-3 ). To remove and replace ceiling light retainer assembly (2), proceed as follows:

(a) Remove screw (5), washer (4) and two nuts (3) to detach lanyard assembly (6).

(b) Remove quick release pin (7) from bracket (8).

(c) Remove four rivets (1) to detach bracket (9).

(d) Replace bracket (9) by securing to center structure roof panel using four rivets (1).

(e) Attach bracket (8) and lanyard assembly (6) to bracket (9) using screw (5), washer (4), and two nuts (3).

**NOTE**

Refer to paragraph 4-7 for rivet removed and replacement procedures.

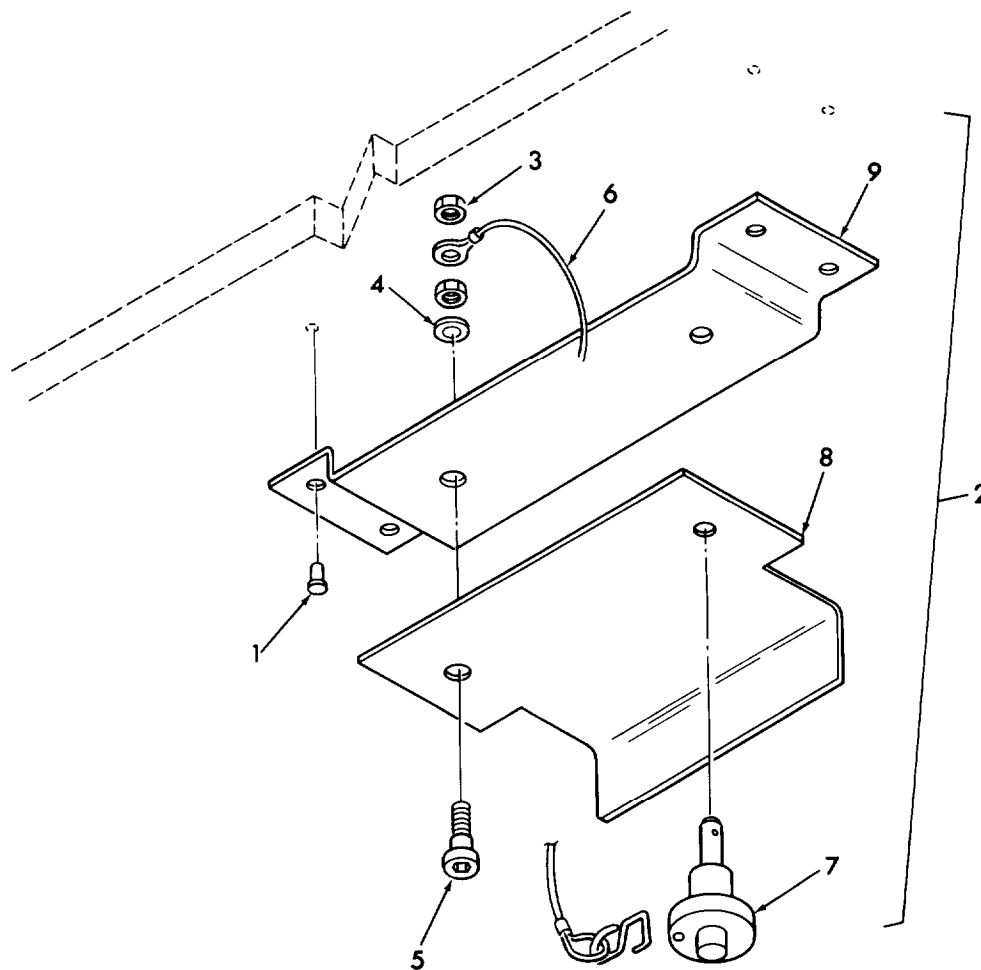

TS 023698

- |                      |                     |
|----------------------|---------------------|
| 1. Rivet (4)         | 6. Lanyard assembly |
| 2. Retainer assembly | 7. Pin              |
| 3. Nut (2)           | 8. Bracket          |
| 4. Washer            | 9. Bracket          |
| 5. Screw             |                     |

Figure 9-3. Ceiling light retainer assembly

## CHAPTER 10

## REPAIR OF PERSONNEL AND CARGO END PANELS

**10-1. Description.**

The description of the personnel and cargo end panels is contained in paragraph 3-21.

**10-2. Cleaning.**

Use a clean, soft bristle brush to remove dust, dirt, and lint from all parts and surfaces of the end panels. Wash panels with soap and water, and a sponge or soft cloth.

**10-3. Inspection and Repair.**

*a. Inspection.* Inspection of the personnel and cargo end panels is accomplished by performing the following procedure:

- (1) Perform inspection procedure of paragraph 5-4a., steps 1 through 10.
- (2) Check condition of reinforcement plates.
- (3) Check safety cable assemblies for ease of operation.
- (4) Check condition of power entrance and utility panels.
- (5) Check condition of exterior light and bracket.
- (6) Check jack supports, mobilizer fittings, and manual holder for security of attachment.
- (7) Check step assemblies and door handles for ease of operation and general condition.
- (8) Check condition of doors and door vents.

*b. Repair.* If personnel end panel or cargo end panel has minor structural damage, repair the panel in accordance with procedures given in paragraph 3-16. If a part attached to the panel is damaged, remove and replace the damaged part as follows:

**NOTE**

For removal and replacement of inserts, follow instructions given in paragraph 4-8.

(1) Removal and replacement of safety cable and latch assembly (fig. 3-17). To remove and replace safety cable assembly (16) and latch assembly (6), proceed as follows:

- (a) Remove two screws (7), lock washers

(8), and flat washers (9) to detach clamp (10).

(b) Remove three screws (1) to detach clip (2) and capstan (3) and remove cable assembly (16).

(c) Inside shelter, remove four screws (11), lock washers (12) and flat washers (13) to detach clamp (14).

(d) Remove two screws (5) to detach latch (15).

(e) Replace latch (15) by securing with two screws (5).

(f) Attach clamp (14) to panel with four screws (11), lock washers (12) and flat washers (13).

(g) Replace clip (2) and capstan (3) with cable assembly (16) in place, using three screws (1).

(h) Attach clamp (10) to clamp (14) with cable assembly (16) in place, using two screws (7), lock washers (8), and flat washers (9).

(2) Removal and replacement of receptacle and stud assembly (fig. 3-16). To remove and replace receptacle and stud assembly (14) from panel, proceed as follows:

(a) Remove receptacle and stud assembly (14) from panel structure.

(b) Remove gasket (15).

(c) Replace gasket (15) and insert new receptacle and stud assembly (14) into panel.

(3) Removal and replacement of ring and stud assembly and lift fitting (fig. 10-1). To remove ring and stud assembly (1) and lift fitting (5), proceed as follows:

(a) Unscrew ring and stud assembly (1) to remove from lift fitting (5).

(b) Remove 11 fasteners (2, 3, and 4) to detach lift fitting (5) from panel.

(c) Replace lift fitting (5) by securing with 11 fasteners (2, 3, and 4).

(d) Screw ring and stud assembly (1) into threaded hole of lift fitting (5).

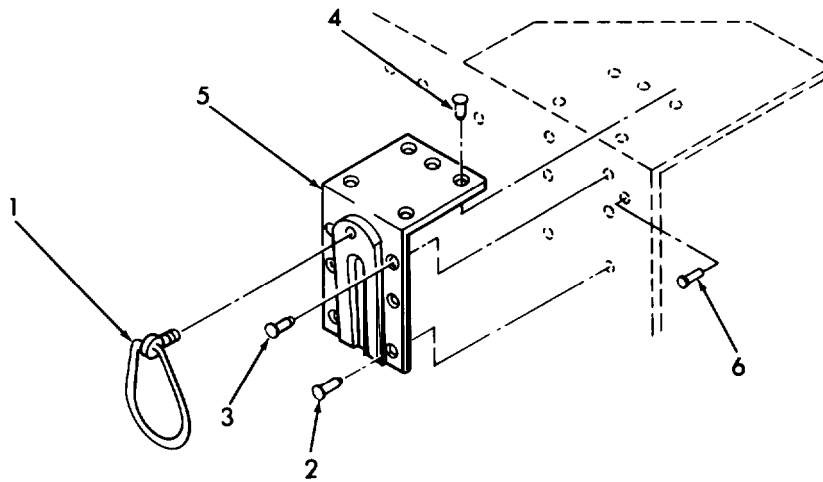

TS 023699

- |                           |                 |
|---------------------------|-----------------|
| 1. Ring and stud assembly | 4. Fastener (5) |
| 2. Fastener (6)           | 5. Fitting      |
| 3. Fastener (2)           | 6. Rivet (58)   |

Figure 10-1. Ring and stud assembly and lift fitting

(4) Removal and replacement of personnel and right and left cargo doors (fig. 3-21 and 3-24). To remove and replace personnel and right and left cargo doors (8), proceed as follows:

(a) Remove two screws (10) and washers (11) from door hinge (12).

(b) Remove 25 rivets (9) to separate door assembly (8) from door hinge (12).

**NOTE**

Refer to paragraph 4-7 for rivet removal and replacement procedures.

(c) Remove two screws (3), lock washers (4) and flat washers (5).

(d) Remove 22 rivets (1) and 5 fasteners (2) to separate hinge (12) from panel,

(e) Remove hinge spacer (6).

(f) Replace hinge spacer (6) and hinge (12) by securing both to panel using two screws (3), lock washers (4) and flat washers (5), 22 rivets (1) and five fasteners (2).

(g) Attach door assembly (8) to hinge (12) using 25 rivets (9).



## CHAPTER 11

REPAIR OF CENTER STRUCTURE FLOOR PANEL

---

**11-1. Description.**

The description of the center structure floor panel is contained in paragraph 3-22.

**11-2. Cleaning.**

Use a clean, soft bristle brush to remove dust, dirt, and lint from all parts and surfaces of the floor panels. Wash floors by scrubbing with soap, clean water, and a mop.

**11-3. Inspection and Repair.**

a. Inspection. Inspection of the center structure floor panel is accomplished by performing the following procedure:

- (1) Perform inspection procedure of paragraph 5-4a., steps 1 through 10.
- (2) Check time guide assemblies for damage.
- (3) Check floor skids and support plates for security of attachment and general condition.
- (4) Check dolly brackets and support angles for damage.

6. *Repair.* If the center structure floor panel has minor structural damage, repair the panel in accordance with procedures given in paragraph 3-16. If a part attached to the center structure floor panel is damaged, remove and replace the damaged part as follows:

**NOTE**

For removal and replacement of inserts, follow instructions given in paragraph 4-8.

(1) Removal and replacement of dolly adapter bracket (fig. 1 1-1). To remove and replace dolly adapter bracket (16), proceed as follows:

(a) Remove six screws (14) and washers (15) and five screws (11), washers (12) and nuts (13) to detach dolly adapter bracket (16).

(b) Replace dolly adapter bracket (16) by securing to center structure floor panel using five screws (11), washers (12), and nuts (13), and six screws (14) and washers (15).

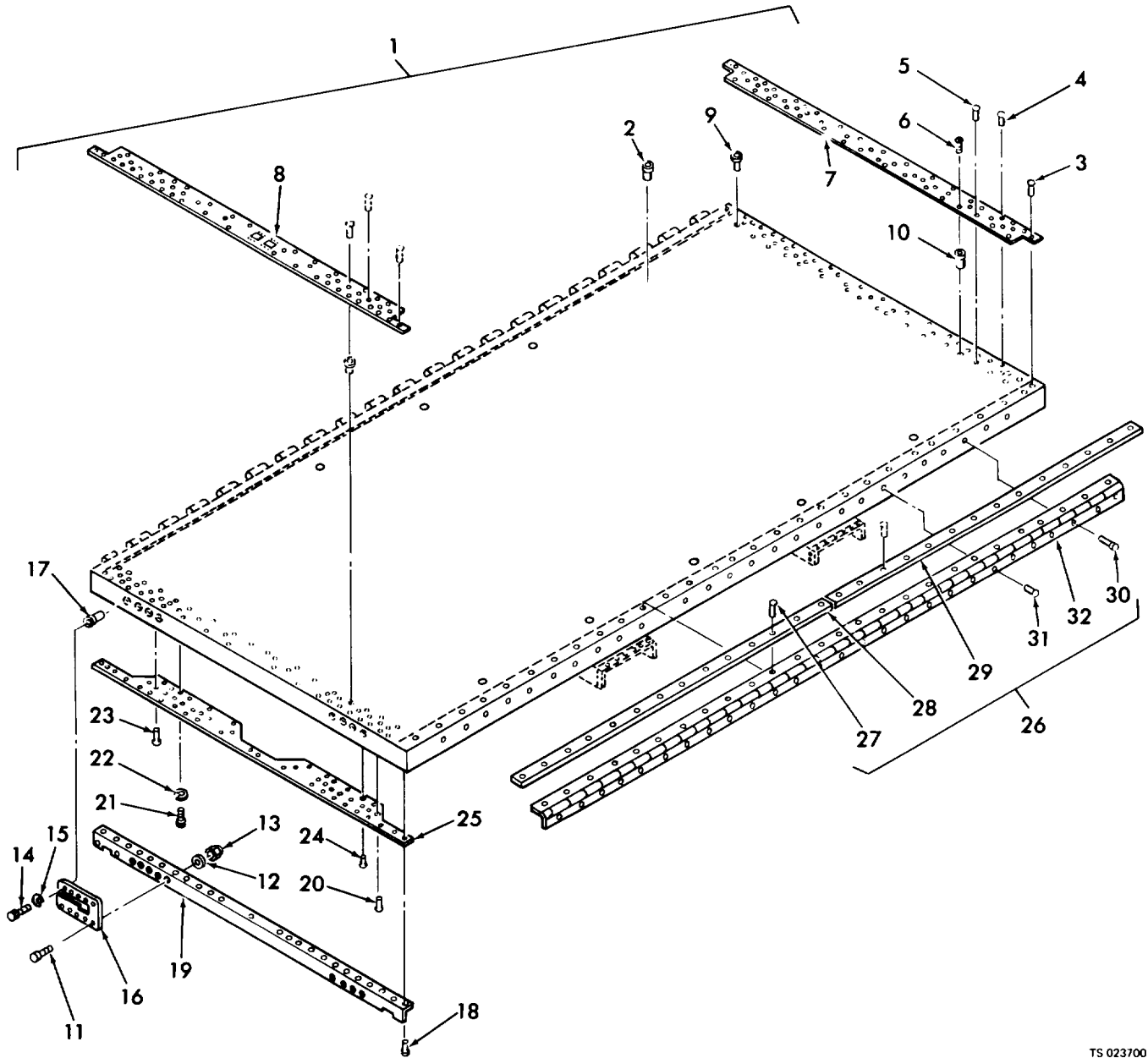

TS 023700

- |                               |                                |
|-------------------------------|--------------------------------|
| 1. Fixed floor panel assembly | 17. Nut (24)                   |
| 2. Insert (10)                | 18. Fastener (52)              |
| 3. Fastener (35)              | 19. Angle (2)                  |
| 4. Rivet (47)                 | 20. Fastener (12)              |
| 5. Rivet (20)                 | 21. Screw (8)                  |
| 6. Screw (12)                 | 22. Washer (8)                 |
| 7. Plate                      | 23. Rivet (24)                 |
| 8. Plate                      | 24. Rivet (16)                 |
| 9. Insert (7)                 | 25. Support (2)                |
| 10. Insert (16)               | 26. Fixed floor panel assembly |
| 11. Screw (20)                | 27. Rivet (56)                 |
| 12. Washer (20)               | 28. Barrier (2)                |
| 13. Nut (20)                  | 29. Barrier (2)                |
| 14. Screw (24)                | 30. Fastener (38)              |
| 15. Washer (24)               | 31. Rivet (160)                |
| 16. Bracket (4)               | 32. Hinge (2)                  |

Figure 11-1. Center structure floor panel

(2) Removal and replacement of floor support angle (fig. 11-1). To remove and replace floor support angle (19), proceed as follows:

(a) Remove 26 fasteners (18) to detach floor support angle (19).

(b) Replace floor support angle (19) by securing to center structure floor panel using 26 fasteners (18).

(3) Removal and replacement of support plate (fig. 11- 1). To remove and replace support plate (25), proceed as follows:

(a) Remove 20 rivets (23 and 24) and six fasteners (20) securing support plate (25).

**NOTE**

Refer to paragraph 4-7 for rivet removal and replacement procedures.

(b) Remove four screws (21) and washers (22) to detach support plate (25).

(c) Replace support plate (25) by attaching to center structure floor panel using four screws (21) and washers (22).

(d) Install 20 rivets (23 and 24) and six fasteners (20) to secure support plate (25).

(4) Removal and replacement of thread plate (fig. 11- 1). To remove and replace thread plate (7 or 8), proceed as follows:

(a) Remove rivets (4 and 5) and fasteners (3) securing thread plate (7 or 8).

**NOTE**

Refer to paragraph 4-7 for rivet removal and replacement procedures.

(b) Remove six screws (6) to detach thread plate (7 or 8).

(c) Attach thread plate (7 or 8) to center structure floor panel using six screws (6).

(d) Secure thread plate (7 or 8) using rivets (4 and 5) and fasteners (3).

(5) Removal and replacement of hinge and thermal barrier (fig. 11- 1). To remove and replace hinge (32) and thermal barrier (28 or 29), proceed as follows:

(a) Remove rivets (31) and fasteners (30) to detach hinge (32).

**NOTE**

Refer to paragraph 4-7 for rivet removal and replacement procedures.

(b) Remove rivets (27) to separate thermal barrier (28 or 29) from hinge (32).

(c) Replace thermal barrier (28 or 29) by securing to hinge (32) using rivets (27).

(d) Replace hinge (32) by securing to center structure floor panel using rivets (31) and fasteners (30).

(6) Removal and replacement of floor skid (fig. 11-2). To remove and replace floor skid (5, 6, or 7), proceed as follows:

(a) Remove screws (1 and 3) and washers (2) to detach floor skid (5, 6, or 7).

(b) Replace floor skid (5, 6, or 7) by securing to center structure floor panel using screws (1 and 3) and washers (2).

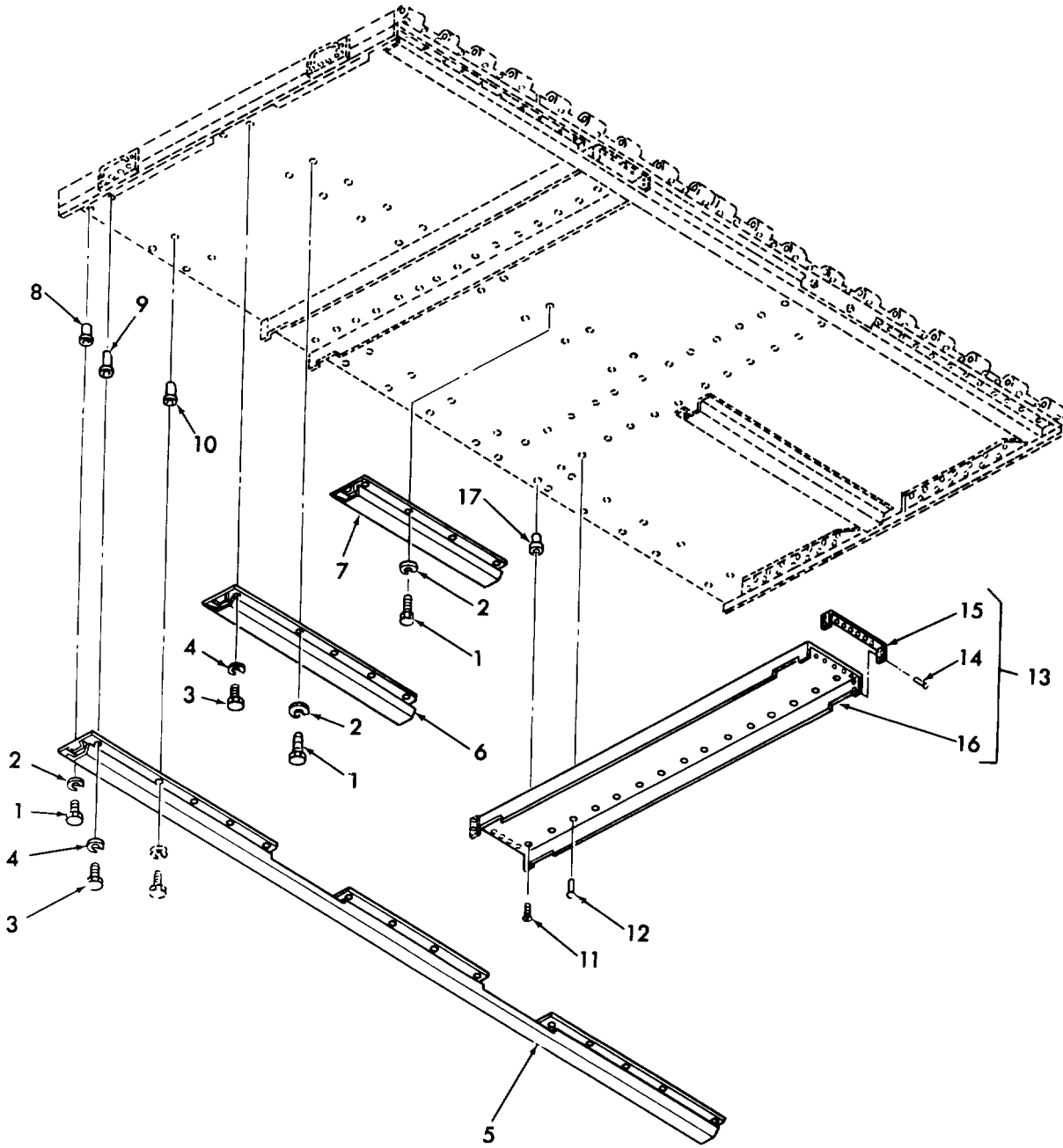

TS023701

- |                |                        |
|----------------|------------------------|
| 1. Screw (76)  | 10. Insert (24)        |
| 2. Washer (76) | 11. Screw (8)          |
| 3. Screw (8)   | 12. Rivet (52)         |
| 4. Washer (8)  | 13. Guide assembly (2) |
| 5. Skid (2)    | 14. Rivet (20)         |
| 6. Skid (2)    | 15. Cap (2)            |
| 7. Skid        | 16. Guide              |
| 8. Nut (52)    | 17. Nut (8)            |
| 9. Nut (8)     |                        |

Figure 11-2. Fixed floor skids and tine guide assembly

(7) Removal and replacement of tine guide assembly (fig. 11-2). To remove and replace tine guide assembly (13), proceed as follows:

(a) Remove 26 rivets (12) securing tine guide assembly (13).

(b) Remove four screws (11) to detach tine guide assembly (13).

(c) Remove 10 rivets (14) to detach cap (15).

(d) Replace cap (15) by securing to tine guide assembly (13) using 10 rivets (14).

(e) Attach tine guide assembly (13) to center structure floor panel using four screws (11).

(f) Secure tine guide assembly (13) using 10 rivets (14).



**CHAPTER 12****REPAIR OF CIRCUIT BREAKER PANEL**

---

**12-1. Description.**

The description of the circuit breaker panel is contained in paragraph 3-25.

**12-2. Removal.**

The removal procedure for the circuit breaker panel is contained in paragraph 4-15a.

**12-3. Cleaning.**

Use a clean, soft bristle brush to remove dust, dirt, and lint from all parts and surfaces of the circuit breaker panel.

**12-4. Inspection and Repair.**

*a.* Check circuit breakers and switches for

security of attachment and proper mechanical operation. If circuit breakers or switches are loose, tighten associated hardware. If circuit breakers or switches do not operate properly, replace defective item.

*b.* Check condition of wires and connections. Repair or replace as required.

*c.* Check general condition of circuit breaker panel structure and door. Repair or replace panels as required.

**12-5. Installation.**

The installation procedure for the circuit breaker panel is contained in paragraph 4-15b.





**APPENDIX A**

**REFERENCES**

---

**A-1. Maintenance**

TM 38-750

The Army Maintenance Management System (TAMMS)

**A-2. Storage**

TM 740-90-1

Administrative Storage of Equipment

**A-3. Destruction**

TM 750-244-3

Procedure for Destruction of Equipment to Prevent Enemy Use



## APPENDIX B

## COMPONENTS OF END ITEMS LIST

## Section I. INTRODUCTION

**B-1. Scope.**

This appendix lists integral components of and basic issue items for the SPAM to help you inventory items required for safe and efficient operation.

**B-2. General.**

The Components of End Item List is divided into the following sections:

*a. Section II Integral Components of the End Item.* These items, when assembled, comprise the SPAM and must accompany it whenever it is transferred or turned in. These illustrations will help you identify these items.

*b. Section III. Basic Issue Items.* These are minimum essential items required to place the SPAM in operation, to operate it, and to perform emergency repairs. Although shipped separately packed they must accompany the SPAM during operation and whenever it is transferred between accountable officers. The illustrations will assist you with hard-to-identify items. This manual is your authority to requisition replacement BII, based on Table(s) of Organization and Equipment (TOE) /Modification Table of Organization and Equipment (MTOE) authorization of the end.

**B-3. Explanation of Columns.**

*a. Illustration.* This column is divided as follows:

(1) Figure Number. Indicates the figure number of the illustration on which the item is shown (if applicable).

(2) Item Number. The number used to identify item called out in the illustration.

*b. National Stock Number (NSN).* Indicates the National stock number assigned to the item and which will be used for requisitioning.

*c. Part Number (P/N).* Indicates the primary number used by the manufacturer, which controls the design and characteristics of the item by means of its engineering drawings, specifications, standards, and inspection requirements to identify an item or range of items.

*d. Description.* Indicates the Federal item name and, if required, a minimum description to identify the item.

*e. Location.* The physical location of each item listed is given in this column. The lists are designed to inventory all items in one area of the major item before moving on to an adjacent area.

*f. Usable on Code.* "USABLE ON" codes are included to help you identify which component items are used on the different models.

## NOTE

When the column is blank the item required is applicable to all items.

*g. quantity Required (Qty Reqd).* This column lists the quantity of each item required for a complete major item.

*h. Quantity.* This column is left blank for use during inventory. Under the Rev'd column, list the quantity you actually receive on your major item. The Date columns are for use when you inventory the major item at a later date; such as for shipment to another site.

**Section II. INTEGRAL COMPONENTS OF END ITEM**

(1) ILLUSTRATION		(2) NATIONAL STOCK NUMBER	(3) PART NO. & FSCM	(4) DESCRIPTION	(5) LOCATION	(6) USABLE ON CODE	(7) QTY REQD	(8) Quantity			
(a) FIGURE NO.	(b) ITEM NO.							RCV'D	DATE	DATE	DATE
3-2		No NSN	484-1038-101	Arrowhead Anchor Assy			12				
3-1				3096200-186-101 (05699) (25500)	Chest, Equipment Storage			1			
3-4		4140-00-001-7993	BC3810FO-5	Fan Assembly			2				
3-1		5975-00-263-0805	GR126	Ground Rod			1				
3-3		5120-01-031-7316	434-1067-101 (05699)	Jack Assembly			8				
3-4		5410-00-218-9545	3080600-054-103 (25500)	Light Assembly, Outside			1				
		No NSN	434-1031-101 (05699)	Seal Assembly			2				

**Section III. BASIC ISSUE ITEMS**

(1) ILLUSTRATION		(2) NATIONAL STOCK NUMBER	(3) PART NO. & FSCM	(4) DESCRIPTION	(5) Location	(6) USABLE ON CODE	(7) QTY REQD	(8) QUANTITY			
(a) FIGURE NO.	(b) ITEM NO.							RCV'D	DATE	DATE	DATE
3-2		4030-00-092-7432	LA-HH-S	Handle, Holding		1					
3-2				LA DRH	Head, Driving		1				
				3096200-190 (25500)	Ring, Tiedown		16				
3-2		5975-01-031-9615	LA-DR3	Rod, Driving		1					
			7/16 (02899) (03914)	Wrench DA Manual TM 10-5410-224-14		1					

## APPENDIX D

MAINTENANCE ALLOCATION CHART (MAC)

---

## Section I. INTRODUCTION

**D-1. The Army Maintenance System MAC**

This introduction provides a general explanation of all maintenance and repair functions authorized at the two maintenance levels under the Two-Level Maintenance System concept.

This MAC (immediately following the introduction) designates overall authority and responsibility for the performance of maintenance functions on the identified end item or component. The application of the maintenance functions to the end item or component shall be consistent with the capacities and capabilities of the designated maintenance levels, which are shown on the MAC in column (4) as:

Field - includes two columns, Unit maintenance and Direct Support maintenance. The Unit maintenance column is divided again into two more subcolumns, C for Operator or Crew and O for Unit maintenance.

Sustainment – includes two subcolumns, General Support (H) and Depot (D).

The tools and test equipment requirements (immediately following the MAC) list the tools and test equipment (both special tools and common tool sets) required for each maintenance function as referenced from the MAC.

The remarks (immediately following the tools and test equipment requirements) contain supplemental instructions and explanatory notes for a particular maintenance function.

**D-2. Maintenance Functions**

Maintenance functions are limited to and defined as follows:

1. Inspect. To determine the serviceability of an item by comparing its physical, mechanical, and/or electrical characteristics with established standards through examination (e.g., by sight, sound, or feel.) This includes scheduled inspection and gaging and evaluation of cannon tubes.
2. Test. To verify serviceability by measuring the mechanical, pneumatic, hydraulic, or electrical characteristics of an item and comparing those characteristics with prescribed standards on a scheduled basis, i.e., load testing of lift devices and hydrostatic testing of pressure hoses.
3. Service. Operations required periodically to keep an item in proper operating condition; e.g., to clean (includes decontaminate, when required), to preserve, to drain, to paint, or to replenish fuel, lubricants, chemical fluids, or gases. This includes scheduled exercising and purging of recoil mechanisms. The following are examples of service functions:
  - a. Unpack. To remove from packing box for service or when required for the performance of maintenance operations.
  - b. Repack. To return item to packing box after service and other maintenance operations.
  - c. Clean. To rid the item of contamination.

- d. Touch up. To spot paint scratched or blistered surfaces.
  - e. Mark. To restore obliterated identification.
4. Adjust. To maintain or regulate, within prescribed limits, by bringing into proper position, or by setting the operating characteristics to specified parameters.
  5. Align. To adjust specified variable elements of an item to bring about optimum or desired performance
  6. Calibrate. To determine and cause corrections to be made or to be adjusted on instruments of test, measuring, and diagnostic equipment used in precision measurement. Consists of comparisons of two instruments, one of which is a certified standard of known accuracy, to detect and adjust any discrepancy in the accuracy of the instrument being compared.
  7. Remove/Install. To remove and install the same item when required to perform service or other maintenance functions. Install may be the act of emplacing, seating, or fixing into position a spare, repair part, or module (component or assembly) in a manner to allow the proper functioning of an equipment or system.
  8. Paint. To prepare and spray color coats of paint so that the ammunition can be identified and protected. The color indicating primary use is applied, preferably, to the entire exterior surface as the background color of the item. Other markings are to be repainted as original so as to retain proper ammunition identification.
  9. Replace. To remove an unserviceable item and install a serviceable counterpart in its place. "Replace" is authorized by the MAC and assigned maintenance level is shown as the third position code of the Source, Maintenance and Recoverability (SMR) code.
  10. Repair. The application of maintenance services, including fault location/troubleshooting, removal/installation, disassembly/assembly procedures and maintenance actions to identify troubles and restore serviceability to an item by correcting specific damage, fault, malfunction, or failure in a part, subassembly, module (component or assembly), end item, or system.

#### NOTE

The following definitions are applicable to the "repair" maintenance function:

Services. Inspect, test, service, adjust, align, calibrate, and/or replace.

Fault location/troubleshooting. The process of investigating and detecting the cause of equipment malfunctioning; the act of isolating a fault within a system or Unit Under Test (UUT).

Disassembly/assembly. The step-by-step breakdown (taking apart) of a spare/functional group coded item to the level of its least component, that is assigned an SMR code for the level of maintenance under consideration (i.e., identified as maintenance significant).

Actions. Welding, grinding, riveting, straightening, facing, machining, and/or resurfacing.

11. Overhaul. That maintenance effort (service/action) prescribed to restore an item to a completely serviceable/operational condition as required by maintenance standards in appropriate technical publications. Overhaul is normally the highest degree of maintenance performed by the Army. Overhaul does not normally return an item to like new condition.
12. Rebuild. Consists of those services/actions necessary for the restoration of unserviceable equipment to a like new condition in accordance with original manufacturing standards. Rebuild is the highest degree of material maintenance applied to Army equipment. The rebuild operation includes the act of returning to zero those age measurements (e.g., hours/miles.) considered in classifying Army equipment/components.

### **D-3. Explanation of Columns in the MAC, Section II**

Column (1) Group Number. Column (1) lists Functional Group Code (FGC) numbers, the purpose of which is to identify maintenance significant components, assemblies, subassemblies, and modules with the Next Higher Assembly (NHA).

Column (2) Component/Assembly. Column (2) contains the names of components, assemblies, subassemblies, and modules for which maintenance is authorized.

Column (3) Maintenance Function. Column (3) lists the functions to be performed on the item listed in column (2). (For a detailed explanation of these functions refer to "Maintenance Functions" outlined above).

Column (4) Maintenance Level. Column (4) specifies each level of maintenance authorized to perform each function listed in column (3), by indicating work time required (expressed as manhours in whole hours or decimals) in the appropriate subcolumn. This work time figure represents the active time required to perform that maintenance function at the indicated level of maintenance. If the number or complexity of the tasks within the listed maintenance function varies at different maintenance levels, appropriate work time figures are to be shown for each level. The work time figure represents the average time required to restore an item (assembly, subassembly, component, module, end item, or system) to a serviceable condition under typical field operating conditions. This time includes preparation time (including any necessary disassembly/assembly time), troubleshooting/fault location time, and quality assurance time in addition to the time required to perform the specific tasks identified for the maintenance functions authorized in the MAC. The system designations for the various maintenance levels are as follows:

#### Field:

- C Operator or Crew maintenance
- O Unit maintenance
- F Direct Support maintenance

#### Sustainment:

- L Specialized Repair Activity
- H General Support maintenance
- D Depot maintenance

## NOTE

The "L" maintenance level is not included in column (4) of the MAC. Functions to this level of maintenance are identified by work time figure in the "H" column of column (4), and an associated reference code is used in the REMARKS column (6). This code is keyed to the remarks and the SRA complete repair application is explained there.

Column (5) Tools and Equipment Reference Code. Column (5) specifies, by code, those common tool sets (not individual tools), common Test, Measurement and Diagnostic Equipment (TMDE), and special tools, special TMDE and special support equipment required to perform the designated function. Codes are keyed to the entries in the tools and test equipment table.

Column (6) Remarks Code. When applicable, this column contains a letter code, in alphabetic order, which is keyed to the remarks table entries.

### **D-4. Explanation of Columns in the Tools and Test Equipment Requirements, Section III**

Column (1) - Tool or Test Equipment Reference Code. The tool or test equipment reference code correlates with a code used in column (5) of the MAC.

Column (2) - Maintenance Level. The lowest level of maintenance authorized to use the tool or test equipment.

Column (3) - Nomenclature. Name or identification of tool or test equipment.

Column (4) - National Stock Number (NSN). The NSN of the tool or test equipment.

Column (5) - Tool Number. The manufacturer's part number.

### **D-5. Explanation of Columns in Remarks, Section IV**

Column (1) - Remarks Code. The code recorded in column (6) of the MAC.

Column (2) - Remarks. This column lists information pertinent to the maintenance function being performed as indicated in the MAC.



**Section II. Maintenance Allocation Chart (MAC) For  
Shelter, Expandable for Shop, Portable, Aircraft Maintenance (SPAM)**

(1) GROUP NUMBER	(2) COMPONENT/ ASSEMBLY	(3) MAINTENANCE FUNCTION	(4) MAINTENANCE LEVEL					(5) TOOLS AND EQUIPMENT REFERENCE CODE	(6) REMARKS CODE
			FIELD		SUSTAINMENT				
			UNIT		DIRECT SUPPORT	GENERAL SUPPORT	DEPOT		
			C	O	F	H	D		
01	SHELTER BODY								
0101	FOLDING PANEL ASSEMBLIES								
	SWINGOUT END WALL	Inspect Replace Repair Overhaul	0.2 1.0	1.5	1.0		1,2 1,2 1,2		
	FOLDOUT END WALLS	Inspect Replace Repair Overhaul	0.2 1.0	1.5	4.0		1,2 1,2 1,2		
	FOLDOUT ROOF PANELS	Inspect Replace Repair Overhaul	0.2 1.0	1.5	4.0		1,2 1,2 1,2		
	FOLDOUT FLOOR PANELS	Inspect Replace Repair Overhaul	0.2 1.0	2.0	4.0		1,2 1,2 1,2		
0102	FIXED PANEL ASSEMBLIES								
	PERSONNEL AND CARGO END PANELS	Inspect Replace Repair Overhaul	0.2 1.0	2.0	4.0		1,2 1,2 1,2		
	CENTER STRUCTURE ROOF PANEL	Inspect Replace Repair Overhaul	0.2 1.0	2.0	4.0		1,2 1,2 1,2		
	CENTER STRUCTURE FLOOR PANEL	Inspect Replace Repair Overhaul	0.2 1.0	2.0	4.0		1,2 1,2 1,2		
0103	SHELTER BODY SEALS	Inspect Replace	0.5 1.5				1		
0104	LEVELING JACK ASSEMBLIES	Inspect Replace Repair	0.5 1.0 1.0						

**Section II. Maintenance Allocation Chart (MAC) For  
Shelter, Expandable for Shop, Portable, Aircraft Maintenance (SPAM) - continued**

(1) GROUP NUMBER	(2) COMPONENT/ ASSEMBLY	(3) MAINTENANCE FUNCTION	(4) MAINTENANCE LEVEL					(5) TOOLS AND EQUIPMENT REFERENCE CODE	(6) REMARKS CODE	
			FIELD		SUSTAINMENT					
			UNIT		DIRECT SUPPORT	GENERAL SUPPORT	DEPOT			
			C	O	F	H	D			
0105	ECU INSTALLATION KIT	Inspect	0.2					1		
		Replace	0.2					1		
		Repair	0.5							
02	ELECTRICAL SYSTEM									
0201		CIRCUIT BREAKER PANEL	Inspect	0.2					1	
			Test	0.5						
			Replace		3.0					1
		Repair		1.0					1	
0202		WIRING	Inspect	0.5						
			Replace	1.0					1	
0203		LIGHT ASSEMBLIES	Inspect	0.2						
			Replace	0.6					1	
	Repair			0.5				1		
0204	RECEPTACLES AND OUTLETS	Inspect	0.2							
		Replace	0.5					1		
0205	FANS, VENTILATION	Inspect	0.2							
		Replace	1.0					1		
		Repair	1.0					1		
03	REPAIR KIT	Inspect	0.2							

**Section III. Tools and Test Equipment Requirements For  
Shelter, Expandable for Shop, Portable, Aircraft Maintenance (SPAM)**

(1) TOOL OR TEST EQUIPMENT REFERENCE CODE	(2) MAINTENANCE LEVEL	(3) NOMENCLATURE	(4) NATIONAL STOCK NUMBER	(5) TOOL NUMBER
1	O	Tool Kit, General Mechanics	6180-00-177-7093-3	
2	O	Riveter, Blind, Hand	5120-00-017-2849	
3	O,F,H	Fastener, Header 10-32 ¼-28		FSCM 03481 P/N C845
4	O,F,H	Fastener, Header 5/16-24 3/8-24		FSCM 03481 P/N C-722
5	O,F,H	Installation Tool, Blind Bolt		FSCM 17446 P/N 115
6	O,F,H	Tool Kit, Blind Bolt Removal		FSCM 17446 P/N 105-60
7	O,F,H	Tool Kit, Blind Bolt Removal		FSCM 17446 P/N 105-80

**Section IV. REMARKS FOR  
SHELTER, EXPANDABLE FOR SHOP, PORTABLE, AIRCRAFT MAINTENANCE (SPAM)**

<b>(1) REMARKS CODE</b>	<b>(2) REMARKS</b>



INDEX

	Paragraph Page		Paragraph Page
<b>A</b>			
Assemblies, Removal and Installation of		Foldout End Walls	6-3 6-1
Major Components and	4-9,4-10 4-4	Foldout Floor Panels	7-3 7-1
<b>c</b>			
Cable, Latch Assembly, and		Foldout Roof Panels	8-3 8-1
Related Parts, Safety	F3-17 3-22	Personnel End Panel	10-2 10-1
Cargo End Panel Assembly	F3-23 3-38	Swingout Walls	5-3 5-1
Cargo Doors Vent Installation,		Components and Assemblies, Removal	
Personnel and	F3-22 3-37	and Installation of Major,	4-9,4-10 4-4
Cargo End Panels, Personnel and	3-21 3-29	Conversion, Shelter	3-3 3-5
General	3-21a 3-29	Corrosion Removal	3-16g 3-28
Inspection	3-21b 3-29	<b>D</b>	
Repair	3-21c 3-29	Damage Repairing Minor Panel	F3-15 3-26
Cargo End Panels, Repair		Both Faces	3-16d 3-27
of Personnel and		Where Face Sheet Is Not Cracked	3-16b 3-25
Cleaning	10-2 10-1	Where Face Sheet Is Surrounded by	
Description	10-1 10-1	Extended Cracks	3-16c 3-16
Inspection	10-3a 10-1	Description	
Inspection and Repair	10-3 10-1	Cargo End Panels	10-1 10-1
Repair	10-3b 10-1	Center Structure Floor Panel	11-1 11-1
Caulking Repaired Areas	3-16f 3-27	Center Structure Roof Panel	9-1 9-1
Center Structure Floor Panel	F11-1 11-1	Circuit Breaker Panel	12-1 12-1
Center Structure Floor Panel, Repair of		Foldout End Walls	6-1 6-1
Cleaning	11-2 11-1	Foldout Floor Panels	7-1 7-1
Description	11-1 11-1	Foldout Roof Panels	8-1 8-1
Inspection	11-3a 11-1	Personnel End Panels	10-1 10-1
Inspection and Repair	11-3 11-1	Swingout Walls	5-1 5-1
Repair	11-3b 11-1	Destruction of Army Materiel to	
Center Structure Roof and		Prevent Enemy Use	1-3 1-1
Floor Panels	3-22 3-41	Drying Out Water-Soaked Areas in Panels	3-16a 3-25
General	3-22a 3-41	<b>E</b>	
Inspection	3-22b 3-41	ECU	
Repair	3-22c 3-41	Installation	2-4 2-1
Center Structure Roof Panel Assembly	F9-1 9-2	Removal	3-3f 3-17
Center Structure Roof Panel,		Removal	3-4e 3-20
Repair of,		ECU Panel	
Cleaning	9-2 9-1	Assembly	F6-2 6-3
Description	9-1 9-1	Closed Position	F3-12 3-17
Inspection	9-3a 9-1	Deployment	F3-14 3-19
Inspection and Repair	9-3 9-1	Inside View	F3-13 3-18
Repair	9-3b 9-1	ECUS	3-29 3-46
Circuit Breaker Panel	3-25,F2-1 3-41,2-2	Electrical System, Maintenance of	3-24 3-41
Assembly	F4-7 4-12	Equipment, Organizational Maintenance	
Cleaning	12-3 12-1	Tools ma	3-6,3-7 3-21
Description	12-1 12-1	Expandable Shelter	F1-1 1-0
General	3-25a 3-41	Conversion	3-3 3-5
Inspection	3-25b 3-41	Description and Data	1-5 1-1
Inspection and Repair	12-4 12-1	Difference in Models	1-6 1-4
Installation	12-5 12-1	Dimensions	F1-2 1-2
Removal	12-2 12-1	Expanding and Leveling	3-3a 3-5
Testing	3-25c 3-41	General Arrangement	F1-3 1-3
Circuit Breaker Panel, Electrical System	4-15 4-12	Maintenance Forms and Records	1-2 1-1
Installation	4-15b 4-12	Operating Instructions	2-1 2-1
Removal	4-15a 4-11	Scope	1-1 1-1
Circuit Breakers, Receptacles, and Switches	T2- 1 2-3	Tabulated Data	1-7 1-4
Cleaning		Expanding and Leveling Shelter	3-3a 3-5
Cargo End Panels	10-2 10-1	<b>F</b>	
Center Structure Floor Panel	112 11-1	Fan Stowage Installation	F9-2 9-3
Center Structure Roof Panel	9-2 9-1	Fitting and Shear Plate, Mobilizer	F3-18 3-33
Circuit Breaker Panel	12-3 12-1	Foldout End Walls	3-18,4-12,3-28,4-7
		Assembly	F4-3 4-6
		Deployment	F3-7 3-10

INDEX

	Paragraph	Page
General	3-18a	3-28
Inspection	3-18b	3-28
Installation	4-12b	4-8
Removal	4-12a	4-7
Repair	3-18c	3-18
Foldout End Walls, Repair of		
Cleaning	6-3	6-1
Description	6-1	6-1
Inspection	6-4a	6-1
Inspection and Repair	6-4	6-1
Installation	6-5	6-4
Removal	6-2	6-1
Repair	6-4b	6-1
Foldout Floor Panels	4-13	4-8
Assembly	F4-5	4-9
Deployment	F3-6	3-9
General	3-20a	3-28
Inspection	3-20b	3-28
Installation	4-13b	4-10
Removal	4-13a	4-8
Repair	3-20c	3-28
Foldout Floor Panels, Repair of		
Cleaning	7-3	7-1
Description	7-1	7-1
Inspection	7-4a	7-1
Inspection and Repair	7-4	7-1
Installation	7-5	7-1
Removal	7-2	7-1
Repair	7-4b	7-1
Foldout Roof Panels	3-19,4-14	3-28,4-10
Assembly	F4-6	4-11
Deployment	F3-5	3-8
General	3-19a	3-28
Inspection	3-19b	3-28
Installation	4-14b	4-10
Removal	4-14a	4-10
Foldout Roof Panels, Repair of,		
Cleaning	8-3	8-1
Description	8-1	8-1
Inspection	8-4a	8-1
Inspection and Repair	8-4	8-1
Installation	8-5	8-2
Removal	8-2	8-1
Repair	8-4b	8-1
Floor Skids and Tine Guide Assembly	F11-2	11-4
Frame Assembly, Seal and	F6-1	6-2

**G**

Ground Anchor		
Installation	3-3b	3-12
Removal	3-4i	3-20
Ground Rod		
Installation	3-3c	3-14
Removal	3-4h	3-20

**H**

Handle and Lock, Personnel and		
Right Cargo Doors	F3-20	3-35
Handling	3-2c	3-4
Hinge, Swingout Wall	F4-4	4-7

**I**

Insert Repair, General Rivet and	4-6	4-2
----------------------------------	-----	-----

	Paragraph	Page
Insert Replacement	4-8	4-2
Installation of BN 527 Series Inserts	4-8d	4-3
Installation of BN 532 Series Inserts	4-8c	4-2
Potting Compound Mixing and Application	4-8b	4-2
Removal	4-8a	4-2
Inserts, Field Installation of	F4-1	4-3
Inspecting and Servicing the Equipment	3-1	3-1
Inspection		
Cargo End Panels	10-3	10-1
Center Structure Floor Panel	11-3	11-1
Center Structure Roof Panel	9-3	9-1
Circuit Breaker Panel	12-4	12-1
Foldout End Walls	6-4	6-1
Foldout Floor Panels	7-4	7-1
Foldout Roof Panels	8-4	8-1
Personnel End Panel	10-3	10-1
Swingout Walls	5-4	5-1
Inspection Upon Receipt of Expandable Shelter	T3-1	3-4
Installation	3-2	3-1
Circuit Breaker Panel	12-5	12-1
ECU		3-17
Electrical	3-3f	3-15
Foldout End Walls	6-5	6-4
Foldout Floor Panels	7-5	7-1
Foldout Roof Panels	8-5	8-2
General	3-2a	3-1
Ground Anchor	3-3b	3-12
Ground Rod	3-3c	3-14
Handling	3-2	3-4
Leveling Jack	F3-4	3-7
Light Fixture	3-3d	3-14
Site Selection	3-2b	3-4
Swingout Walls	5-5	5-1
Utility Outlet	3-3e	3-17
Ventilation Fan	3-3g	3-19

**L**

Latch Assembly, and Related		
Parts, Safety Cable	F3-17	3-32
Leveling Jack Lubrication	3-10	3-22
Leveling Jacks	3-23	3-41
Deployment	F3-3	3-6
General	3-23a	3-41
Inspection	3-23b	3-41
Repair	3-23c	3-41
Left Fitting, Ring and Stud Assembly and	F10-1	10-2
Light Assemblies	3-27	3-42
General	3-27a	3-42
Inspection	3-27b	3-42
Installation	3-27e	3-44
Removal	3-27d	3-43
Repair	3-27c	3-42
Light Assembly, Exterior	F3-26	3-43
Light Fixture		
Installation	3-3d	3-14
Removal	3-4g	3-20
Light Retainer Assembly, Ceiling	F9-3	9-4
Lights	2-2	2-1
Lock, Personnel and Right Cargo		
Doors Handle and	F3-20	3-35
Lubrication		
General	3-9	3-22
Leveling Jack	3-10	3-22

INDEX

	Paragraph	Page		Paragraph	Page
<b>M</b>					
Maintenance			Installation	3-26d	3-42
Electrical System	3-24	3-41	Removal	3-26c	3-42
Forms and Records	1-1	1-1	Receptacles and Switches, Circuit Breakers	T2-1	2-3
Shelter Body	3-15	3-25	Reinstallation after Movement	3-5	3-21
Teds and Equipment	4-1,4-2	4-1	Removal		
Maintenance, Operator			Circuit Breaker Panel	12-2	12-1
General	3-11	3-22	Corrosion	3-16g	3-28
Preventive Checks and Services	T3-2-3-12	3-22	ECU	3-4e	3-20
Maintenance, Organizational			Foldout End Walls"	6-2	6-1
Preventive Checks and Services	3-12, T3-3	3-22	Foldout Floor Panels	7-2	7-1
Repair Parts	3-8	3-21	Foldout Roof Panels	8-2	8-1
Tools and Equipment	3-6,3-7	3-21	Ground Anchor...	3-4i	3-20
Troubleshooting	3-13	3-23	Ground Rod	3-4h	3-20
Maintenance Repair Parts	4-3	4-1	Light Fixture	3-4g	3-20
Materials, Repair...	T3-5	3-25	Swingout Walls	5-2	5-1
Movement, Dismantling for	3-4	3-20	Utility Outlet	3-4f	3-20
Moving, Preparing Shelter for	3-4j	3-20	Ventilation Fan	3-2d	3-20
<b>O</b>					
Operating Instructions	2-1	2-1	Repair		
ECU	2-4	2-1	Cargo End Panels	10-3	10-1
General	2-1	2-1	Center Structure Floor Panel	11-3	11-1
Lights	2-2	2-1	Center Structure Roof Panel	9-3	9-1
Outlets	2-5	2-1	Circuit Breaker Panel	12-4	12-4
Ventilation Fans	2-3	2-1	Foldout End Walls	6-4	6-1
Outlets	2-5	2-1	Foldout Floor Panels	7-4	7-1
Outlets, Wiring, Receptacles and	3-26	3-42	Foldout Roof Panels	8-4	7-1
General	3-26a	3-42	Materials	T3-5	3-25
Inspection	3-26b	3-42	parts, Organizational Maintenance	3-8	3-21
Installation	3-26d	3-42	Personnel End Panel	10-3	10-1
Removal	3-26c	3-42	Shelter Body	3-16	3-25
			Swingout Walls	5-4	5-1
<b>P</b>					
Paint Data.....	T3-6	3-28	Ring and Stud Assembly and Lift and Fitting..	F10-1	10-2
Paint Refinishing	3-16h	3-28	Rivet and Insert Repair, General	4-6	4-2
Panel Assembly, Personnel End	F3-16	3-30	Rivet Replacement, Blind Type	4-7	4-2
Panel Faces, Repairing Both	3-16d	3-27	Removal	4-7a	4-2
Personnel and Cargo End Panels	3-21	3-29	Replacement	4-7b	4-2
General	3-21a	3-29			
Inspection	3-21b	3-29	<b>S</b>		
Repair	3-21c	3-29	Seal and Frame Assembly	F6-1	6-2
Personnel and Cargo End Panels, Repair of			Seals, Replacing Shelter	3-16e	3-27
cleaning	10-2	10-1	Servicing Instructions,	3-1	3-1
Description	10-1	10-1	Servicing the Equipment, Inspecting and	3-1	3-1
Inspection	10-3a	10-1	Shelter		
Inspection and Repair	10-3	10-1	Body Repair	3-16	3-25
Repair k	10-3b	10-1	Conversion	3-3	3-5
Personnel and Left Cargo Doors Assembly	F3-24	3-40	Maintenance of Body	3-15	3-25
Personnel and Right Cargo Doors			Schematic Diagram	F3.25	
Assembly	F3-21	3-36	Shelter Conversion	3-3	3-5
Personnel End Panel	F3-2	3-5	Site selection	3-2b	3-4
Power Entrance Panel....	F2-1	2-2	Storage, Administrative	1-4	1-1
Preventive Maintenance			Storage Locations	F3-1	3-2
Operator and Organizational	3.12	3-22	Strikes and Related Parts	F3-19	3-34
Operator Preventive Maintenance			Strut Assembly and Related		
Checks and Services	T3-2	3-22	Parts, Support	F8-1	8-2
Organizational Preventive Maintenance			Stud Assembly and Lift		
Checks and Services	T3-3	3-22	Fitting, Ring and	F10-1	10-2
<b>R</b>					
Receptacles and Outlets, Wiring,	3-26	3-42	<b>Swingout Walls</b>	<b>3-17.4.113.284.4</b>	
General	3-26a	3-42	A s s e m b l y ,	F4-2	4-5
Inspection	3-26b	3-42	Deployment of	F3-9	3-12
			General	3-17a	3-28
			I n s p e c t i o n	3-17b	3-28

INDEX

	Paragraph	Page
Installation	4-11b	4-7
Removal	4-11a	4-4
Repair	3-17c	3-28
Unlocking	F3-8	3-11
Swingout Walls, Repair of		
Cleaning	5-3	5-1
Description	5-1	5-1
Inspection	5-4a	5-1
Inspection and Repair	5-4	5-1
Installation	5-5	5-1
Removal	5-2	5-1
Repair	5-4b	5-1
Switch, Ventilation Fan	F2-2	2-3
Switches, Circuit breakers, Receptacles and	T2-1	2-3
<b>T</b>		
Tools and Equipment, Organizational Maintenance	3-6.3-7	3-21
Troubleshooting		
Direct and General Support Maintenance	T4-1	4-1
General	4-4	4-1
Table	4-5	4-1
Troubleshooting, Organizational Maintenance		
General	3-13	3-23

	Paragraph	Page
Table	3-14	3-23
<b>U</b>		
Utility Outlet		
Installation	3-3e	3-17
Removal	3-4f	3-20
<b>V</b>		
Ventilation Fan		
Assembly	3-27f	3-45
Installation	3-3g	3-19
Removal	3-4d	3-20
Ventilation, Fans	2-3.3-28 2-1.3-44	
General	3-28a	3-44
Inspection	3-28b	3-44
Installation	3-28e	3-46
Removal	3-28d	3-44
Repair	3-28c	3-44
<b>W</b>		
Wiring, Receptacle and Outlets	3-26	3-42
General	3-26a	3-42
Inspection	3-26b	3-42
Installation	3-26d	3-42
Removal	3-26c	3-42



By Order of the Secretary of the Army:

BERNARD W. ROGERS  
*General United States Army*  
*Chief of Staff*

Official:

PAUL T. SMITH  
*Major General, United States Army*  
*The Adjutant General*

Distribution:

To be distributed in accordance with DA Form 12-25A, Operator maintenance requirements for Shelters.



## ***These are the instructions for sending an electronic 2028***

The following format must be used if submitting an electronic 2028. The subject line must be exactly the same and all fields must be included; however only the following fields are mandatory: 1, 3, 4, 5, 6, 7, 8, 9, 10, 13, 15, 16, 17, and 27.

From: "Whomever" <whomever@avma27.army.mil>

To: amssbriml@natick.army.mil

Subject: DA Form 2028

1. From: Joe Smith
2. Unit: home
3. Address: 4300 Park
4. City: Hometown
5. St: MO
6. Zip: 77777
7. Date Sent: 19-OCT-93
8. Pub no: 55-2840-229-23
9. Pub Title: TM
10. Publication Date: 04-JUL-85
11. Change Number: 7
12. Submitter Rank: MSG
13. Submitter FName: Joe
14. Submitter MName: T
15. Submitter LName: Smith
16. Submitter Phone: 123-123-1234
17. Problem: 1
18. Page: 2
19. Paragraph: 3
20. Line: 4
21. NSN: 5
22. Reference: 6
23. Figure: 7
24. Table: 8
25. Item: 9
26. Total: 123
27. Text:

This is the text for the problem below line 27.



<b>RECOMMENDED CHANGES TO PUBLICATIONS AND BLANK FORMS</b> For use of this form, see AR 25-30; the proponent agency is ODISC4.						Use Part II ( <i>reverse</i> ) for Repair Parts and Special Tool Lists (RPSTL) and Supply Catalogs/Supply Manuals (SC/SM).	<b>DATE</b> <i>21 October 2003</i>
<b>TO:</b> ( <i>Forward to proponent of publication or form</i> ) ( <i>Include ZIP Code</i> ) COMMANDER U.S. ARMY TANK-AUTOMOTIVE AND ARMAMENT COMMAND ATTN: AMSTA-LC-CECT 15 KANSAS STREET NATICK, MA 01760-5052						<b>FROM:</b> ( <i>Activity and location</i> ) ( <i>Include ZIP Code</i> )  <i>PFC Jane Doe</i> <i>CO A 3<sup>rd</sup> Engineer BR</i> <i>Ft. Leonardwood, MO 63108</i>	
<b>PART I – ALL PUBLICATIONS (EXCEPT RPSTL AND SC/SM) AND BLANK FORMS</b>							
<b>PUBLICATION/FORM NUMBER</b>  TM 10-1670-296-23&P				<b>DATE</b>  30 October 2002	<b>TITLE</b>  Unit Manual for Ancillary Equipment for Low Velocity Air Drop Systems		
<b>ITEM NO.</b>	<b>PAGE NO.</b>	<b>PARA-GRAPH</b>	<b>LINE NO. *</b>	<b>FIGURE NO.</b>	<b>TABLE NO.</b>	<b>RECOMMENDED CHANGES AND REASON</b> <i>(Provide exact wording of recommended changes, if possible).</i>	
	0036 00-2				1	<i>In table 1, Sewing Machine Code Symbols, the second sewing machine code symbol should be MD ZZ not MD 22.</i>  <i>Change the manual to show Sewing Machine, Industrial: Zig-Zag; 308 stitch; medium-duty; NSN 3530-01-181-1421 as a MD ZZ code symbol.</i>	
<i>*Reference to line numbers within the paragraph or subparagraph.</i>							
<b>TYPED NAME, GRADE OR TITLE</b>  Jane Doe, PFC				<b>TELEPHONE EXCHANGE/AUTOVON, PLUS EXTENSION</b>  508-233-4141		<b>SIGNATURE</b>  Jane Doe <i>Jane Doe</i>	

<b>TO:</b> <i>(Forward direct to addressee listed in publication)</i> COMMANDER U.S. ARMY TANK-AUTOMOTIVE AND ARMAMENT COMMAND ATTN: AMSTA-LC-CECT 15 KANSAS STREET NATICK, MA 01760-5052	<b>FROM:</b> <i>(Activity and location) (Include ZIP Code)</i> <i>PFC Jane Doe</i> <i>CO A 3<sup>rd</sup> Engineer BR</i> <i>Ft. Leonardwood, MO 63108</i>	<b>DATE</b> 21 October 2003
--	---	--------------------------------

**PART II – REPAIR PARTS AND SPECIAL TOOL LISTS AND SUPPLY CATALOGS/SUPPLY MANUALS**

<b>PUBLICATION NUMBER</b> TM 10-1670-296-23&P	<b>DATE</b> 30 October 2002	<b>TITLE</b> Unit Manual for Ancillary Equipment for Low Velocity Air Drop Systems
--	--------------------------------	---

PAGE NO.	COLM NO.	LINE NO.	NATIONAL STOCK NUMBER	REFERENCE NO.	FIGURE NO.	ITEM NO.	TOTAL NO. OF MAJOR ITEMS SUPPORTED	RECOMMENDED ACTION
0066 00-1					4			<i>Callout 16 in figure 4 is pointed to a <u>D-Ring</u>. In the Repair Parts List key for figure 4, item 16 is called a <u>Snap Hook</u>. Please correct one or the other.</i>

SAMPLE

**PART III – REMARKS** *(Any general remarks or recommendations, or suggestions for improvement of publications and blank forms. Additional blank sheets may be used if more space is needed.)*

TYPED NAME, GRADE OR TITLE	TELEPHONE EXCHANGE/AUTOVON, PLUS EXTENSION	SIGNATURE
----------------------------	--	-----------

<b>RECOMMENDED CHANGES TO PUBLICATIONS AND BLANK FORMS</b> For use of this form, see AR 25-30; the proponent agency is ODISC4.						Use Part II ( <i>reverse</i> ) for Repair Parts and Special Tool Lists (RPSTL) and Supply Catalogs/Supply Manuals (SC/SM).	DATE
TO: ( <i>Forward to proponent of publication or form</i> ) ( <i>Include ZIP Code</i> ) Commander U.S. Army Tank-automotive and Armament Command ATTN: AMSTA-LC-CECT Kansas Street, Natick, MA 01760-5052						FROM: ( <i>Activity and location</i> ) ( <i>Include ZIP Code</i> )	
<b>PART I - ALL PUBLICATIONS (EXCEPT RPSTL AND SC/SM) AND BLANK FORMS</b>							
PUBLICATION/FORM NUMBER TM 10-5410-224-14						DATE 16 February 1977	TITLE Operator, Organizational, Direct Support and General Support Maintenance Manual for Shelter, Expandable for Shop, Portable, Aircraft Maintenance (SPAM)
ITEM NO.	PAGE NO.	PARA-GRAPH	LINE NO. *	FIGURE NO.	TABLE NO.	RECOMMENDED CHANGES AND REASON <i>(Provide exact wording of recommended changes, if possible).</i>	
<i>*Reference to line numbers within the paragraph or subparagraph.</i>							
TYPED NAME, GRADE OR TITLE					TELEPHONE EXCHANGE/AUTOVON, PLUS EXTENSION		SIGNATURE

<b>TO:</b> <i>(Forward direct to addressee listed in publication)</i> Commander U.S. Army Tank-automotive and Armament Command ATTN: AMSTA-LC-CECT Kansas Street, Natick, MA 01760-5052	<b>FROM:</b> <i>(Activity and location) (Include ZIP Code)</i>	<b>DATE</b>
---	--	-------------

**PART II – REPAIR PARTS AND SPECIAL TOOL LISTS AND SUPPLY CATALOGS/SUPPLY MANUALS**

<b>PUBLICATION NUMBER</b> TM 10-5410-224-14	<b>DATE</b> 16 February 1977	<b>TITLE</b> Operator, Organizational, Direct Support and General Support Maintenance Manual for Shelter, Expandable for Shop, Portable, Aircraft Maintenance (SPAM)
--	---------------------------------	--

PAGE NO.	COLM NO.	LINE NO.	NATIONAL STOCK NUMBER	REFERENCE NO.	FIGURE NO.	ITEM NO.	TOTAL NO. OF MAJOR ITEMS SUPPORTED	RECOMMENDED ACTION

**PART III – REMARKS** *(Any general remarks or recommendations, or suggestions for improvement of publications and blank forms. Additional blank sheets may be used if more space is needed.)*

Empty space for remarks
-------------------------

<b>TYPED NAME, GRADE OR TITLE</b>	<b>TELEPHONE EXCHANGE/AUTOVON, PLUS EXTENSION</b>	<b>SIGNATURE</b>
-----------------------------------	---	------------------



<b>RECOMMENDED CHANGES TO PUBLICATIONS AND BLANK FORMS</b> For use of this form, see AR 25-30; the proponent agency is ODISC4.						Use Part II ( <i>reverse</i> ) for Repair Parts and Special Tool Lists (RPSTL) and Supply Catalogs/Supply Manuals (SC/SM).	DATE
TO: ( <i>Forward to proponent of publication or form</i> ) ( <i>Include ZIP Code</i> ) Commander U.S. Army Tank-automotive and Armament Command ATTN: AMSTA-LC-CECT Kansas Street, Natick, MA 01760-5052						FROM: ( <i>Activity and location</i> ) ( <i>Include ZIP Code</i> )	
<b>PART I - ALL PUBLICATIONS (EXCEPT RPSTL AND SC/SM) AND BLANK FORMS</b>							
PUBLICATION/FORM NUMBER TM 10-5410-224-14						DATE 16 February 1977	TITLE Operator, Organizational, Direct Support and General Support Maintenance Manual for Shelter, Expandable for Shop, Portable, Aircraft Maintenance (SPAM)
ITEM NO.	PAGE NO.	PARA-GRAPH	LINE NO. *	FIGURE NO.	TABLE NO.	RECOMMENDED CHANGES AND REASON <i>(Provide exact wording of recommended changes, if possible).</i>	
<i>*Reference to line numbers within the paragraph or subparagraph.</i>							
TYPED NAME, GRADE OR TITLE					TELEPHONE EXCHANGE/AUTOVON, PLUS EXTENSION		SIGNATURE

<b>TO:</b> <i>(Forward direct to addressee listed in publication)</i> Commander U.S. Army Tank-automotive and Armament Command ATTN: AMSTA-LC-CECT Kansas Street, Natick, MA 01760-5052	<b>FROM:</b> <i>(Activity and location) (Include ZIP Code)</i>	<b>DATE</b>
---	--	-------------

**PART II – REPAIR PARTS AND SPECIAL TOOL LISTS AND SUPPLY CATALOGS/SUPPLY MANUALS**

<b>PUBLICATION NUMBER</b> TM 10-5410-224-14	<b>DATE</b> 16 February 1977	<b>TITLE</b> Operator, Organizational, Direct Support and General Support Maintenance Manual for Shelter, Expandable for Shop, Portable, Aircraft Maintenance (SPAM)
--	---------------------------------	--

PAGE NO.	COLM NO.	LINE NO.	NATIONAL STOCK NUMBER	REFERENCE NO.	FIGURE NO.	ITEM NO.	TOTAL NO. OF MAJOR ITEMS SUPPORTED	RECOMMENDED ACTION

**PART III – REMARKS** *(Any general remarks or recommendations, or suggestions for improvement of publications and blank forms. Additional blank sheets may be used if more space is needed.)*

Empty space for remarks
-------------------------

<b>TYPED NAME, GRADE OR TITLE</b>	<b>TELEPHONE EXCHANGE/AUTOVON, PLUS EXTENSION</b>	<b>SIGNATURE</b>
-----------------------------------	---	------------------

<b>RECOMMENDED CHANGES TO PUBLICATIONS AND BLANK FORMS</b> For use of this form, see AR 25-30; the proponent agency is ODISC4.						Use Part II ( <i>reverse</i> ) for Repair Parts and Special Tool Lists (RPSTL) and Supply Catalogs/Supply Manuals (SC/SM).	DATE
TO: ( <i>Forward to proponent of publication or form</i> ) ( <i>Include ZIP Code</i> ) Commander U.S. Army Tank-automotive and Armament Command ATTN: AMSTA-LC-CECT Kansas Street, Natick, MA 01760-5052						FROM: ( <i>Activity and location</i> ) ( <i>Include ZIP Code</i> )	
<b>PART I - ALL PUBLICATIONS (EXCEPT RPSTL AND SC/SM) AND BLANK FORMS</b>							
PUBLICATION/FORM NUMBER TM 10-5410-224-14						DATE 16 February 1977	TITLE Operator, Organizational, Direct Support and General Support Maintenance Manual for Shelter, Expandable for Shop, Portable, Aircraft Maintenance (SPAM)
ITEM NO.	PAGE NO.	PARA-GRAPH	LINE NO. *	FIGURE NO.	TABLE NO.	RECOMMENDED CHANGES AND REASON <i>(Provide exact wording of recommended changes, if possible).</i>	
<i>*Reference to line numbers within the paragraph or subparagraph.</i>							
TYPED NAME, GRADE OR TITLE					TELEPHONE EXCHANGE/AUTOVON, PLUS EXTENSION		SIGNATURE

<b>TO:</b> <i>(Forward direct to addressee listed in publication)</i> Commander U.S. Army Tank-automotive and Armament Command ATTN: AMSTA-LC-CECT Kansas Street, Natick, MA 01760-5052	<b>FROM:</b> <i>(Activity and location) (Include ZIP Code)</i>	<b>DATE</b>
---	--	-------------

**PART II – REPAIR PARTS AND SPECIAL TOOL LISTS AND SUPPLY CATALOGS/SUPPLY MANUALS**

<b>PUBLICATION NUMBER</b> TM 10-5410-224-14	<b>DATE</b> 16 February 1977	<b>TITLE</b> Operator, Organizational, Direct Support and General Support Maintenance Manual for Shelter, Expandable for Shop, Portable, Aircraft Maintenance (SPAM)
--	---------------------------------	--

PAGE NO.	COLM NO.	LINE NO.	NATIONAL STOCK NUMBER	REFERENCE NO.	FIGURE NO.	ITEM NO.	TOTAL NO. OF MAJOR ITEMS SUPPORTED	RECOMMENDED ACTION

**PART III – REMARKS** *(Any general remarks or recommendations, or suggestions for improvement of publications and blank forms. Additional blank sheets may be used if more space is needed.)*

<b>TYPED NAME, GRADE OR TITLE</b>	<b>TELEPHONE EXCHANGE/AUTOVON, PLUS EXTENSION</b>	<b>SIGNATURE</b>
-----------------------------------	---	------------------

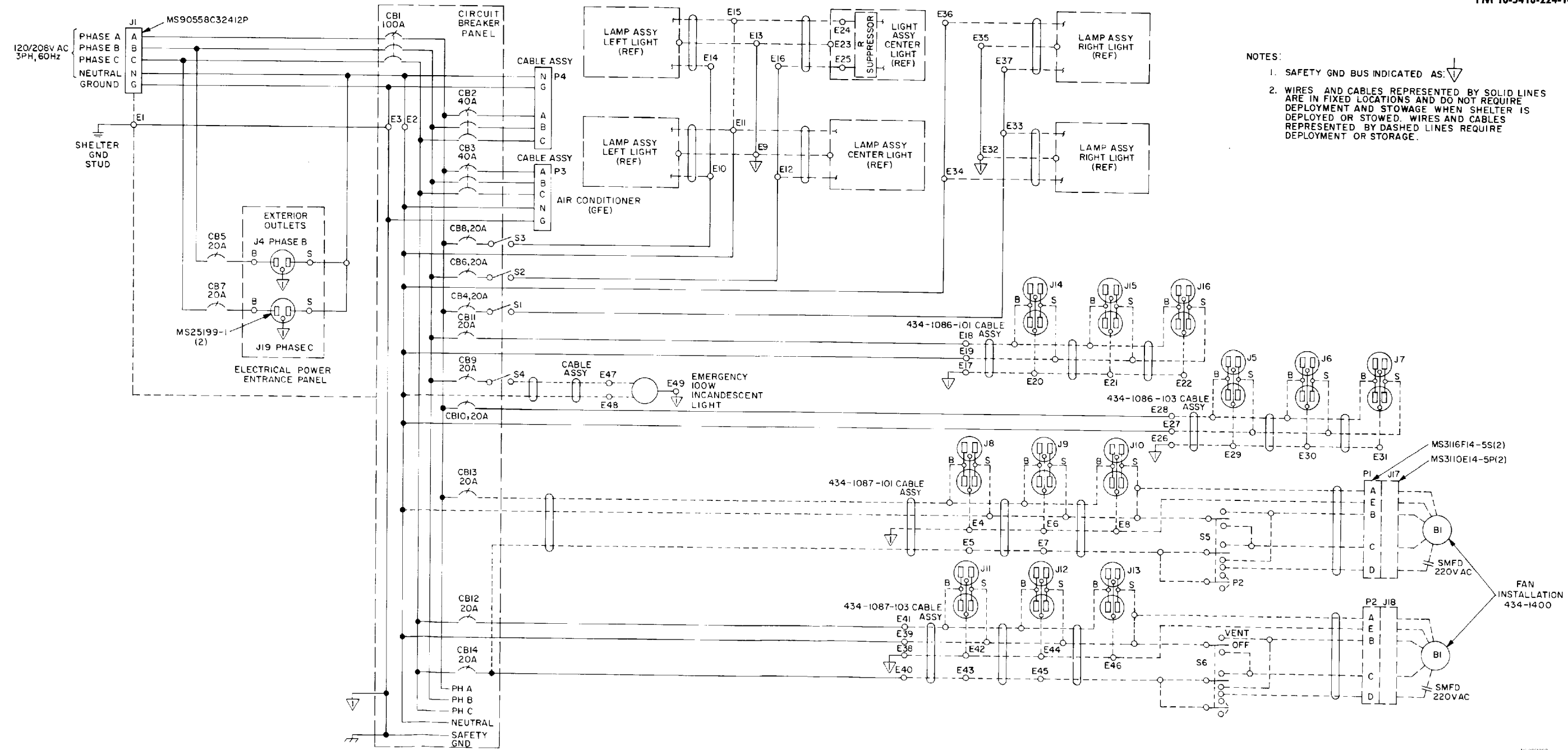

- NOTES:
1. SAFETY GND BUS INDICATED AS:
  2. WIRES AND CABLES REPRESENTED BY SOLID LINES ARE IN FIXED LOCATIONS AND DO NOT REQUIRE DEPLOYMENT AND STOWAGE WHEN SHELTER IS DEPLOYED OR STOWED. WIRES AND CABLES REPRESENTED BY DASHED LINES REQUIRE DEPLOYMENT OR STORAGE.

F01. Expandable shelter, schematic diagram



# The Metric System and Equivalents

## Linear Measure

1 centimeter = 10 millimeters = .39 inch  
 1 decimeter = 10 centimeters = 3.94 inches  
 1 meter = 10 decimeters = 39.37 inches  
 1 dekameter = 10 meters = 32.8 feet  
 1 hectometer = 10 dekameters = 328.08 feet  
 1 kilometer = 10 hectometers = 3,280.8 feet

## Weights

1 centigram = 10 milligrams = .15 grain  
 1 decigram = 10 centigrams = 1.54 grains  
 1 gram = 10 decigrams = .035 ounce  
 1 dekagram = 10 grams = .35 ounce  
 1 hectogram = 10 dekagrams = 3.52 ounces  
 1 kilogram = 10 hectograms = 2.2 pounds  
 1 quintal = 100 kilograms = 220.46 pounds  
 1 metric ton = 10 quintals = 1.1 short tons

## Liquid Measure

1 centiliter = 10 milliliters = .34 fl. ounce  
 1 deciliter = 10 centiliters = 3.38 fl. ounces  
 1 liter = 10 deciliters = 33.81 fl. ounces  
 1 dekaliter = 10 liters = 2.64 gallons  
 1 hectoliter = 10 dekaliters = 26.42 gallons  
 1 kiloliter = 10 hectoliters = 264.18 gallons

## Square Measure

1 sq. centimeter = 100 sq. millimeters = .155 sq. inch  
 1 sq. decimeter = 100 sq. centimeters = 15.5 sq. inches  
 1 sq. meter (centare) = 100 sq. decimeters = 10.76 sq. feet  
 1 sq. dekameter (are) = 100 sq. meters = 1,076.4 sq. feet  
 1 sq. hectometer (hectare) = 100 sq. dekameters = 2.47 acres  
 1 sq. kilometer = 100 sq. hectometers = .386 sq. mile

## Cubic Measure

1 cu. centimeter = 1000 cu. millimeters = .06 cu. inch  
 1 cu. decimeter = 1000 cu. centimeters = 61.02 cu. inches  
 1 cu. meter = 1000 cu. decimeters = 35.31 feet

## Approximate Conversion Factors

<i>To change</i>	<i>To</i>	<i>Multiply by</i>	<i>To change</i>	<i>To</i>	<i>Multiply by</i>
inches	centimeters	2.540	ounce-inches	newton-meters	.007062
feet	meters	.305	centimeters	inches	.394
yards	meters	.914	meters	feet	3.280
miles	kilometers	1.609	meters	yards	1.094
square inches	square centimeters	6.451	kilometers	miles	.621
square feet	square meters	.093	square centimeters	square inches	.155
square yards	square meters	.836	square meters	square feet	10.764
square miles	square kilometers	2.590	square meters	square yards	1.196
acres	square hectometers	.405	square kilometers	square miles	.386
cubic feet	cubic meters	.028	square hectometers	acres	2.471
cubic yards	cubic meters	.765	cubic meters	cubic feet	35.315
fluid ounces	milliliters	29.573	cubic meters	cubic yards	1.308
pints	liters	.473	milliliters	fluid ounces	.034
quarts	liters	.946	liters	pints	2.113
gallons	liters	3.785	liters	quarts	1.057
ounces	grams	28.349	liters	gallons	.264
pounds	kilograms	.454	grams	ounces	.035
short tons	metric tons	.907	kilograms	pounds	2.205
pound-feet	newton-meters	1.356	metric tons	short tons	1.102
pound-inches	newton-meters	.11296			

## Temperature (Exact)

  °F Fahrenheit temperature  $\times \frac{5}{9}$  (after subtracting 32) = Celsius temperature   °C

